

Workshop manual

Group 21-26, 30

A
2(0)

D1-13, D1-20, D1-30, D2-40

Group 21–26, 30

Marine diesel engines

D1-13 A, D1-20 A, D1-30 A, D2-40 A

Contents

Safety information	3	Repair instructions	
General information	6	When working with chemicals, fuel and lubricating oil	29
About this Workshop Manual	6	Before working in a boat	29
Spare parts	6	Before lifting the engine	29
Certified engines	6	Condition test, engine	30
Repair instructions	7	Compression test	30
Our common responsibility	7	Actions after lifting the engine	30
Torque	7	Cooling system, draining	31
Torque-angle tightening	8	Engine oil, draining/changing	31
Lock nuts	8	Engine fixture, fixing	32
Strength classes	8		
Sealant	8		
Safety rules for fluorocarbon rubber	9		
		Group 21 Short block	
Special tools	10	Short block, disassembly	33
		Inspection, component change, overhaul and assembly of the short block engine	37-53
Design and function		Inspecting the engine block	37
Group 21 Short block		Inspecting the cylinder head	38
Engine, general	12	Changing the valve seats	38
Engine block	16	Grinding of valve and valve seats	39
Cylinder head	16	Checking the valve guides	40
Crankshaft	17	Renovating the rocker arm mechanism	41
Timing gear	18	Inspecting the crankshaft	42
Crankcase breather	18	Inspection of the and crankshaft bushing and crankshaft journal	42
Group 22 Lubrication system		Inspection of main and big end bearings.	42
Lubrication oil system	19	Checking the big end bearing clearance:	43
Oil valves	20	Piston ring inspection and fits	44
Oil pump	20	Inspection and measurement of piston and cylinder bore.	44
Oil filter	20	Inspecting the con rod	45
Group 23 Fuel system		Changing the gudgeon pin bushing	45
Fuel system	21	Assembling the piston, piston rings and con rod.	46
Injection pump	22	Camshafts and valve lifters, inspection	47
Centrifugal regulator	22	Measuring the camshaft	47
Injectors	22	Installing the crankshaft	49
Fuel filter	23	Installing the piston in the cylinder and the oil pan	50
Feed pump	23	Installing the timing gear and injection pump	51
Group 26 Cooling system		Flank clearance, checking	52
Cooling system	24	Measuring the piston height, installing the cylinder head and other assembly	53
Thermostat	25		
Heat exchanger	25		
Sea water pump	25		
Coolant pump	25		
Group 30 Electrical system			
Electrical system	26		
Alternator	27		
Starter motor	27		
Distribution box	27		
Electrical components	28		

Continued on next page

Cylinder head, removal.....	56	Group 26 Cooling system	
Valves, removing	58	Coolant	90
Valves, installation	58	Pressure valve in filler cap, checking	91
Cylinder head, installation	59	Fault causes, cooling system	91
Timing gear, removing	61	Thermostat, change	92
Timing gear, installation	64	Heat exchanger, cleaning	93
Pistons, removal	67	Heat exchanger/exhaust manifold, changing	94
Big end bearing, change	68	Seawater pump, impeller change	95
Pistons, change	68	Sea water pump, change	96
Pistons, installation	69	Coolant pump, change	97
Crankshaft, remove	70	Group 30 Electrical system	
Main bearings, change	71	Alternator, changing	98
Crankshaft, assembly	73	Starter motor, changing	99
Flywheel, change	74	Wiring diagram	100
Crankcase seal rear, change	75	Technical data	103
Crankshaft seal, front, change	76	References to Service Bulletins	116
Valves, adjustment	77		
Drive belt, change	79		
Group 22 Lubrication system			
Oil pump bearing, changing	80		
Group 23 Fuel system			
Injection pump, changing	81		
Injectors, changing	83		
Injectors, testing	85		
Injectors, check	85		
Setting the engine speed	86		
Feed pump, changing	87		
Hand pump, changing	88		
Fuel system, venting	89		

Safety information

Introduction

This workshop manual contains technical data, descriptions and repair instructions for the Volvo Penta products or product versions noted in the table of contents. Check that you have the correct Workshop Manual for your engine.

Read the available safety information, "General information" and "Repair instructions" in the workshop manual before you start to do any service work.

Important

In this book and on the product you will find the following special warning symbols.

 **WARNING!** Warns for the risk of personal injury, major damage to product or property, or serious malfunctions if the instruction is ignored.

 **IMPORTANT!** Is used to call attention to things which could cause damage or malfunctions to product or property.

NOTE! Is used to call attention to important information, to facilitate work processes or operation.

Below is a summary of the risks involved and safety precautions you should always observe or carry out when operating or servicing the engine.

 Make it impossible to start the engine by cutting system current with the main switch(es) and lock it (them) in the off position before starting service work. Set up a warning notice by the helm station.

 As a general rule all service operations must be carried out with the engine stopped. Some tasks, such as adjustments, need the engine to be running, however. Approaching an engine which is operating is a safety hazard. Remember that loose clothing or long hair can fasten in rotating parts and cause serious personal injury.

If work is done adjacent to a running engine, a careless movement or a dropped tool can lead to personal injury in the worst case.

Take care to avoid contact with hot surfaces (exhaust pipes, Turbocharger, air intake pipe, starter heater etc.) and hot fluids in pipes and hoses in an engine which is running or has just been stopped. Reinstall all protective parts removed during service work before starting the engine.

 Check that the warning or information labels on the product are always clearly visible. Replace labels which have been damaged or painted over.

 Never start the engine without installing the air cleaner filter. The rotating compressor turbine in the turbocharger can cause severe injury. Foreign objects entering the intake ducts can also cause mechanical damage.

 Never use start spray or similar products as a starting aid. They may cause an explosion in the inlet manifold. Danger of personal injury.











 Avoid opening the coolant filling cap when the engine is hot. Steam or hot coolant can spray out and the system pressure will be lost. Open the filler cap slowly, and release the pressure in the cooling system if the filling cap or tap has to be opened, or if a plug or coolant hose has to be removed when the engine is hot. Steam or hot coolant might spray out in an unexpected direction.





 Hot oil can cause burns. Avoid skin contact with hot oil. Ensure that the lubrication system is not under pressure before carrying out any work. Never start or operate the engine with the oil filler cap removed, otherwise oil could be ejected.

 Stop the engine and close the sea cocks before doing any work on the cooling system.

 Only start the engine in a well-ventilated area. When operated in a confined space, exhaust fumes and crankcase gases must be ventilated from the engine bay or workshop area.

 Always use protective glasses or goggles when carrying out work where there is a risk of splinters, grinding sparks, acid splashes or where other chemicals are used. Your eyes are extremely sensitive, injury could cause blindness!

-  Avoid getting oil on your skin! Repeated exposure to oil or exposure over a long period can result in the skin becoming dry. Irritation, dryness and eczema and other skin problems can then occur. Used oil is more dangerous than fresh oil from a health aspect. Use protective gloves and avoid oil soaked clothes and rags. Wash regularly, especially before eating. There are special skin creams which counteract drying out of the skin and make it easier to clean off dirt after work is completed.
-  Most chemicals intended for the product (e.g. engine and transmission oils, glycol, petrol (gasoline) and diesel oil) or chemicals for workshop use (e.g. degreasers, paints and solvents) are hazardous. Read the instructions on the product packaging with care! Always follow the safety precautions for the product (for example use of protective mask, glasses, gloves etc.). Make sure that other personnel are not inadvertently exposed to hazardous chemicals, for example in the air. Ensure good ventilation in the work place. Follow the instructions provided when disposing of used or leftover chemicals.
-  Exercise extreme care when leak detecting on the fuel system and testing the fuel injector nozzles. Use eye protection. The jet which comes from a fuel injector has very high pressure and considerable penetrationability. Fuel can force its way deep into body tissue and cause severe injury. Danger of blood poisoning (septicemia).
-  All fuels, and many chemicals, are flammable. Do not allow naked flame or sparks in the vicinity. Petrol (gasoline), some thinners and hydrogen gas from batteries are extremely flammable and explosive when mixed with air in the correct ratio. No smoking! Ensure that the work area is well ventilated and take the necessary safety precautions before starting welding or grinding work. Always ensure that there are fire extinguishers at hand when work is being carried out.
-  Make sure that oil and fuel soaked rags, and used fuel and oil filters are stored in a safe place. Rags soaked in oil can spontaneously ignite under certain circumstances. Used fuel and oil filters are polluting waste and must be handed to an approved waste management facility for destruction, together with used lubrication oil, contaminated fuel, paint residue, solvents, degreasers and wash residue.
-  Batteries must never be exposed to open flames or electric sparks. Never smoke close to the batteries. The batteries generate hydrogen gas when charged, which forms an explosive gas when mixed with air. This gas is easily ignited and highly volatile. A spark, which can be caused by incorrect battery connection, can cause a single spark which is sufficient to cause an explosion with resulting damage. Do not move the connections when you attempt to start the engine (risk of arcing), and do not stand and lean over one of the batteries.
-  Always ensure that the Plus (positive) and Minus (negative) battery cables are correctly installed on the corresponding terminal posts on the batteries. Incorrect installation can result in serious damage to the electrical equipment. Refer to the wiring diagram.
-  Always use protective goggles when charging and handling the batteries. Battery electrolyte contains sulfuric acid which is highly corrosive. Should the battery electrolyte come into contact with unprotected skin wash off immediately using plenty of water and soap. If you get battery acid in your eyes, flush at once with a generous amount of water, and get medical assistance at once.
-  Turn the engine off and turn off the power at the main switch(es) before carrying out work on the electrical system.
-  Clutch adjustments must be carried out with the engine stopped.
-  The existing lugs on the engine/reversing gear should be used for lifting the assembly. Always check that the lifting devices are in good condition and that they have the correct capacity for the lift (the weight of the engine plus the reversing gear and extra equipment). The engine should be lifted with a customized or adjustable lifting boom for safe handling and to avoid damaging components on top of the engine. All chains or cables should be parallel to each other and should be as square as possible to the top of the engine. If other equipment connected to the engine has altered its center of gravity, special lifting devices may be needed to obtain the correct balance and safe handling. Never do any work on an engine which just hangs from a lifting device.

-
-  Never work alone when removing heavy engine components, even when using lifting devices such as locking tackle lifts. When using a lifting device two people are usually required to do the work, one to take care of the lifting device and another to ensure that components are lifted clear and not damaged during the lifting operations.
When you work aboard a boat, always make sure that there is enough space for disassembly where you are working, with no risk of personal injury or material damage.
 -  Components in the electrical and fuel systems on Volvo Penta products have been designed to minimize the risks of explosion and fire. The engine must not be run in areas where there are explosive materials.
 -  Remember the following when washing with a power washer: Never aim the water jet at seals, rubber hoses or electrical components. Never use a power washer for engine cleaning.
 -  Only use the fuels recommended by Volvo Penta. Refer to the Instruction Book. Use of fuels that are of a lower quality can damage the engine. On a diesel engine, poor quality fuel can cause the control rod to bind and the engine to overrev with resulting risk of damage to the engine and personal injury. Poor fuel can also lead to higher maintenance costs.
-

General information

About this Workshop Manual

This workshop manual contains technical data, descriptions and repair instructions for the following marine diesel engines: D1-13, D1-20, D1-30 and D2-40.

The engine designation and number are noted on the number plate and engine decal. The engine designation and number must always be given in all correspondence about any product.

The Workshop Manual is produced primarily for the use of Volvo Penta workshops and service technicians. This assumes that people who use the Manual have basic knowledge of marine drive systems and can do the tasks of a mechanical or electrical nature associated with the trade.

Volvo Penta constantly improves its products, so we reserve the right to make modifications without prior notification. All information in this manual is based on product data which was available up to the date on which the manual was printed. Any material changes introduced into the product or service methods after this date are notified by means of Service Bulletins.

Spare parts

Spare parts for electrical- and fuel systems are subject to various national safety requirements, such as U.S. Coast Guard Safety Regulations. Volvo Penta Original Spare Parts meet these specifications. Any damage, occasioned by use of non-original Volvo Penta spares for the product, will be not be compensated by the warranty offered by Volvo Penta.

Certified engines

When doing service and repair on emission certified engines, it is important to be aware of the following:

Certification means that an engine type has been checked and approved by the relevant authority. The engine manufacturer guarantees that all engines made of the same type are equivalent to the certified engine.

This makes special demands on service and repair work, as follows:

- Maintenance and service intervals recommended by Volvo Penta must be complied with.
- Only Volvo Penta original spares may be used.
- Service to injection pumps, pump settings and injectors must always be done by an authorized Volvo Penta workshop.
- The engine must not be converted or modified, except for the accessories and service kits which Volvo Penta has approved for the engine.
- No installation changes to the exhaust pipe and engine air inlet ducts may be done.
- No seals on the engine may be broken by unauthorized persons.

The general advice in the instruction book about operation, care and maintenance applies.



IMPORTANT! Delayed or inferior care/maintenance, and the use of non-original spares, parts means that AB Volvo Penta can no longer be responsible for guaranteeing that the engine complies with the certified version.

Damage and/or costs which arise from this will not be compensated by Volvo Penta.

Repair instructions

The working methods described in the Workshop Manual apply to work carried out in a workshop. For this reason, the engine is lifted out of the boat and mounted on an engine support. Unless otherwise stated, reconditioning work which can be carried out with the engine in place follows the same working method.

The warning signs which occur in the workshop manual (please refer to "Safety information" for their meanings)

 **WARNING!**

 **IMPORTANT!**

NOTE!

are not comprehensive in any way, since we can not of course foresee everything, because service work is done in highly varying circumstances. For this reason, all we can do is to point out the risks which we believe could occur due to incorrect work in a well-equipped workshop, using work methods and tools tested by us.

All operations described in the Workshop Manual for which there are Volvo Penta Special Tools available assume that these tools are used when carrying out the repair. Volvo Penta Special Tools have been specifically developed to ensure the most safe and rational working methods possible. It is therefore the responsibility of anyone using other tools or other working methods than we recommend to determine that there is no risk of personal injury or mechanical damage or malfunction as a result.

In some cases special safety precautions and user instructions may be required in order to use the tools and chemicals mentioned in the Workshop Manual. These rules must always be observed, so there are no special instructions about this in the workshop manual.

By following these basic recommendations and using common sense it is possible to avoid most of the risks involved in the work. A clean workplace and a clean engine will eliminate many risks of personal injury and engine malfunction.

Above all, when work on fuel systems, lubrication systems, induction systems, turbocharger, bearing caps and seals is done, it is extremely important that no dirt or other kinds of foreign particles are able to get in, since this would otherwise cause malfunctions or shortened repair life.

Our common responsibility

Each engine consists of many interacting systems and components. The deviation of one component from the technical specification can dramatically increase the environmental impact caused by an otherwise good engine. For this reason, it is important that the specified wear tolerances are observed, that systems which are adjustable are correctly adjusted and that Volvo Penta Original Spares are used for the engine. The stated service intervals in the Maintenance Schedule must be observed.

Some systems, such as the components in the fuel system, require special expertise and special testing equipment for service and maintenance. For environmental reasons etc., some components are sealed at the factory. It is only permissible to work on sealed components if you are authorized to do such work.

Remember that most chemical products, incorrectly used, damage the environment. Volvo Penta recommends the use of biodegradable degreasers whenever engine components are de-greased, unless otherwise specified in the workshop manual. When working aboard a boat, be careful to ensure that oils, wash residue etc. are processed for destruction, and are not inadvertently discharged with bilge water into the environment.

Torque

The tightening torque for vital fasteners, which should be tightened with a torque wrench, are listed in "Technical Data: Special tightening torques" and noted in the job descriptions in the book. All torque specifications apply to clean screws, screw heads and mating faces. Torque data stated apply to lightly oiled or dry threads. If lubricants, locking fluids or sealants are needed on a fastener, the type of preparation to be used will be noted in the job description. For fasteners where specific torque values are not given, please refer to "Technical data, General Tightening Torque".

Torque-angle tightening

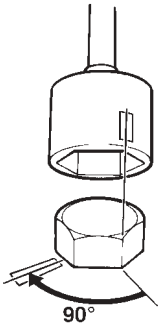

In torque/angle tightening, the fastener is tightened to the specified torque, and tightening then continues through a pre-determined angle. Example; for 90° angle tightening, the fastener is tightened a further 1/4 turn in one sequence, after the specified tightening torque has been achieved.

Lock nuts

Disassembled locknuts shall not be re-used, they shall be replaced by new ones, since the locking properties are impaired or lost when the nut is used several times. On locknuts with plastic inserts, such as Nylock®, the tightening torque specified in the table must be reduced if the Nylock® nut has the same nut height as a standard fully metallic hexagonal nut. Reduce the torque by 25% for screw size 8 mm or larger. On Nylock® nuts with higher nut height, where the fully metallic thread is as high as on a standard hexagonal nut, use the tightening torques in the table.

Strength classes

Screws and nuts are sub-divided into different strength classes. The classification is shown by a marking on the screw head. Markings of a higher number indicate stronger material. For example, a screw marked 10-9 is stronger than one marked 8-8. For this reason, it is important when fasteners are dismantled, that the screws are put back in the correct places when they are re-installed. If a screw must be replaced check in the spare parts catalogue to make sure the correct screw is used.

Sealant

The sealants and locking fluids noted below shall be used on the engines covered by this manual.

To ensure service work is correctly carried out it is important that the correct sealant and locking fluid type is used on the joint where the agents are required.

In this Volvo Penta Workshop Manual the user will find that each section where these agents are applied in production states which type was used on the engine.

When sealants and locking fluids are used, it is important that the surfaces are free from oil, grease, paint and rust-protection, and that they are dry. Always follow the manufacturer's instructions use regarding temperature range, curing time and any other instructions for the product,

Two different basic types of agent are used on the engine. These are:

RTV preparations (Room Temperature Vulcanizing). Used for gaskets, sealing gasket joints or coating gaskets. RTV is visible when a part has been disassembled; old RTV must be removed before resealing the joint.

The following RTV preparations are used on the engine:

Volvo Penta sealant (cartridge 0.31 l, part. no. 1161231-4, or tube 20 g., part. no. 1161277-7) and part. no. 840879-1 (tube 25 g).

Remove old sealant with denatured alcohol.

Anaerobic agents. These agents cure in the absence of air. These preparations are used when two solid components, such as two cast components, are fitted together without a gasket. Common uses are also to lock and seal plugs, stud threads, taps, oil pressure monitors etc.

Hardened anaerobic preparations are glassy and for this reason, the preparations are colored to make them visible.

Hardened anaerobic preparations are highly resistant to solvents, and old compound must be removed mechanically. On re-assembly, it is important to degrease components carefully first, wipe off and apply new sealant in accordance with the instructions.

The following anaerobic preparations are used on the engines:

Volvo Penta thread locking fluid (part. no. 1161053-2) and sealing compound (part. no. 1161059-9).

Safety rules for fluorocarbon rubber

Fluorocarbon rubber is a common material in seal rings for shafts, and in O-rings, for example.

When fluorocarbon rubber is exposed to high temperatures (above 300°C), **hydrofluoric acid** can be formed, which is highly corrosive. Contact with the skin can result in severe chemical burns. Splashes in your eyes can result in severe chemical burns. If you breathe in the fumes, your lungs can be permanently damaged.

⚠ WARNING! Observe the greatest care in working on engines which might have been exposed to high temperatures, such as overheating during flame cutting or a fire. Seals must never be cut with a flame torch during disassembly, or burned in uncontrolled circumstances afterwards.

- Always use chloroprene rubber gloves (gloves for chemicals handling) and goggles.

- Handle the removed seal in the same way as corrosive acid. All residue, including ash, can be highly corrosive. Never use compressed air to blow anything clean.
- Put the remains in a plastic container, seal it and apply a warning label. Wash the gloves under running water before removing them.

The following seals are most probably made from fluorocarbon rubber:

Seal rings for the crankshaft, camshaft, drive shafts.

O-rings, regardless of where they are installed. O-rings for cylinder liner sealing are almost always made of fluorocarbon rubber.

Please note that seals which have not been exposed to high temperature can be handled normally.

NOTE! As the illustrations in the service literature refer to several engine variants, certain details may differ from any particular engine. The essential information in the illustrations is always correct, however.

Special tools

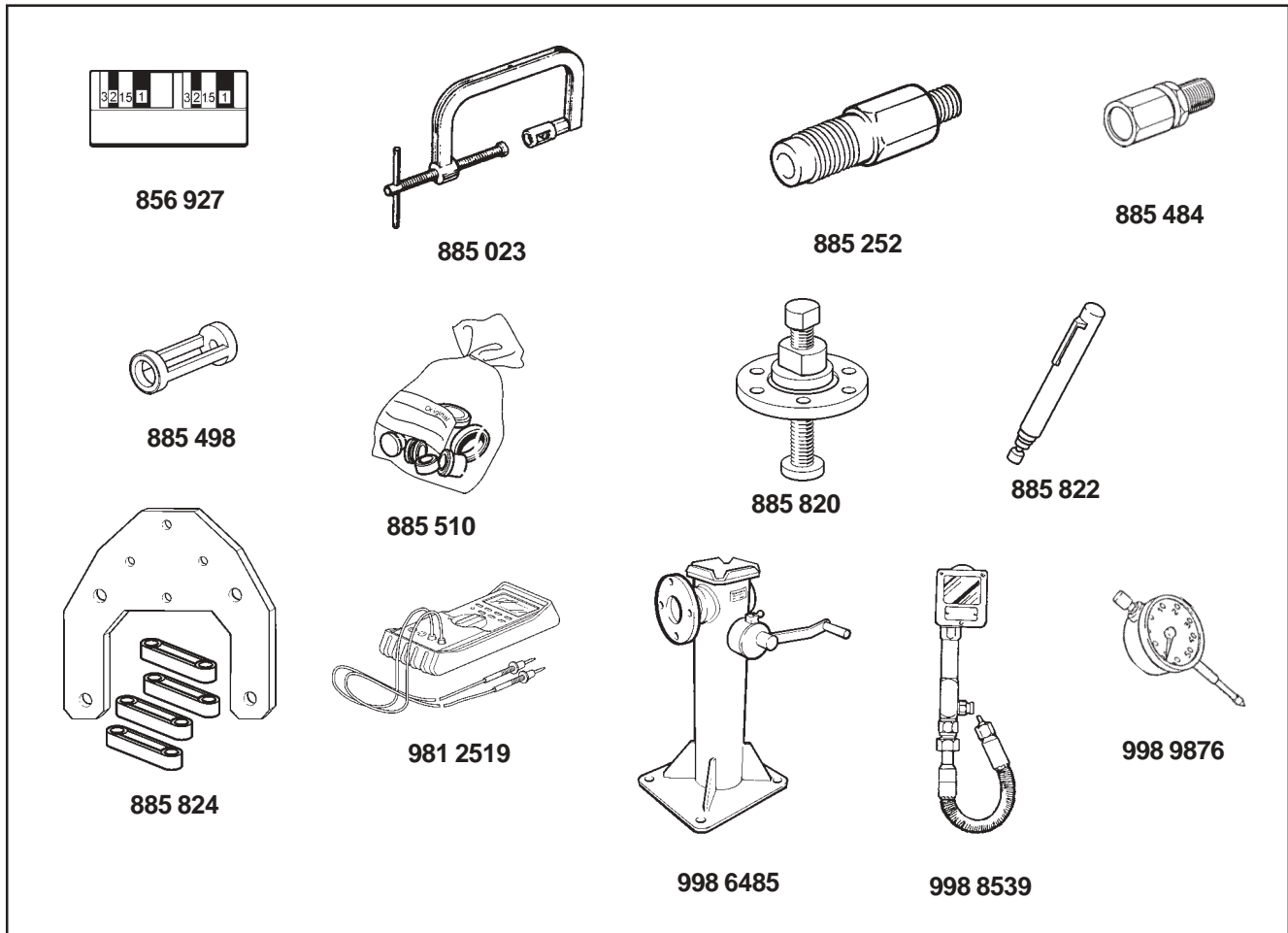

- 856 927** Measurement putty, for measuring main and big end bearing clearance.
- 885 023** Valve spring compressor
- 885 252** Adapter for testing compression pressure
- 885 484** Adapter for testing compression pressure
- 885 498** Pressure foot, for valve compressor
- 885 510** Protective caps, fuel system
- 885 820** Puller, for pulley
- 885 822** Magnetic pen
- 885 824** Engine fixture
- 981 2519** Multimeter
- 998 6485** Equipment stand
- 998 8539** Compression tester
- 998 9876** Dial gauge

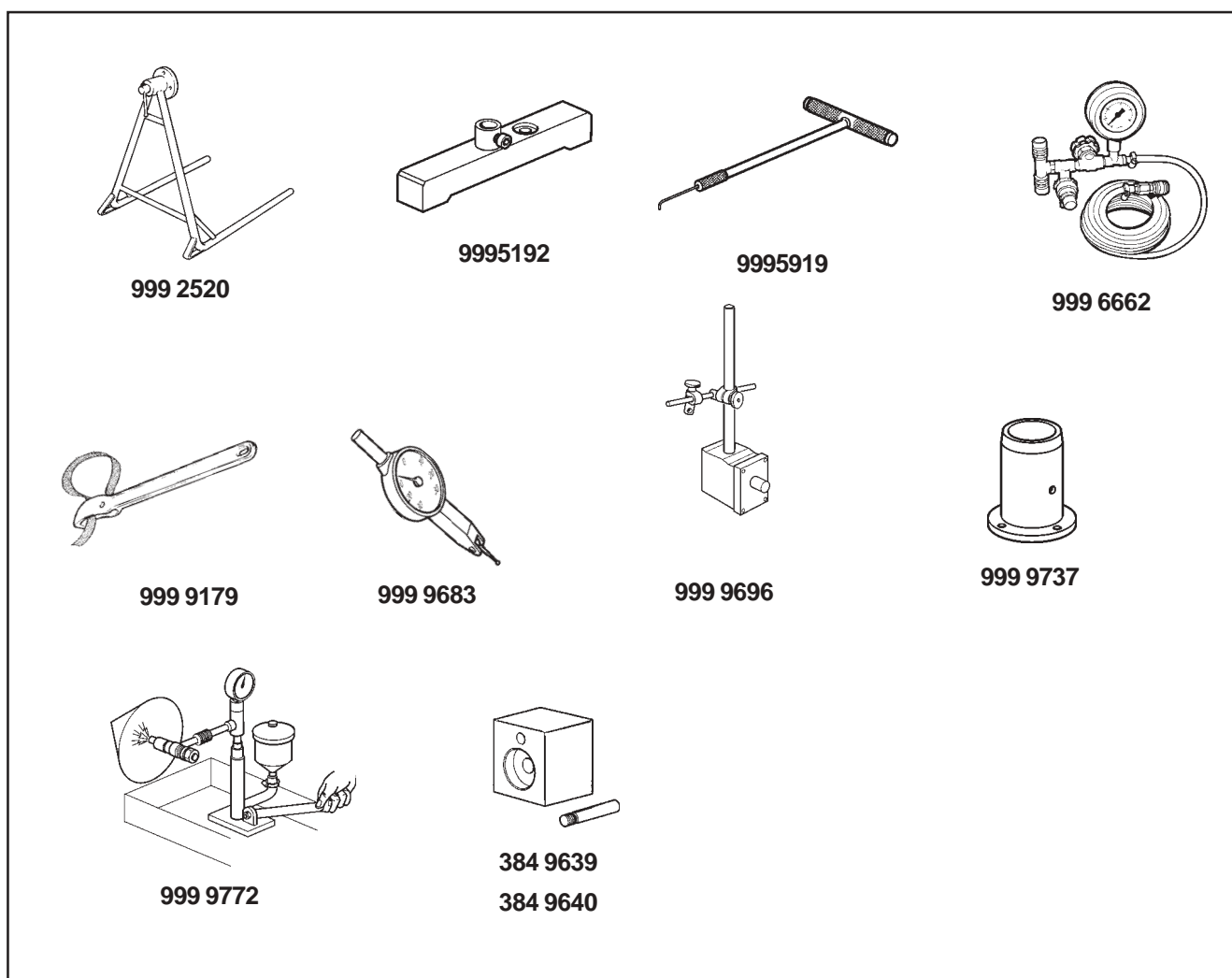

- 999 2520** Equipment stand
- 999 5192** **Holder, dial gauge, piston height measurement**
- 999 5919** Puller, seals
- 999 6662** Pressure testing device
- 999 9179** Spanner for removing fuel/oil filters
- 999 9683** Dial gauge
- 999 9696** Magnetic stand
- 999 9737** Fixture cylinder, for fixture 885 824
- 999 9772** Injector tester
- 384 9639** Installation tool for oil pump shaft (D1-13, D1-20)
- 384 9640** Installation tool for oil pump shaft (D1-30, D2-40)

Design and function

Group 21 Short block

Engine, general

The D1-13, D1-20, D1-30 and D2-40 are four cycle marine diesel propulsion engines. They all have two valves per cylinder, a high-mounted camshaft in the engine block and a mechanical injection pump.

The D1-13 is an in-line two cylinder engine with a total swept volume of 0.51 liter. The D-20 and D1-30 are in-line three cylinder engines with total swept volumes of 0.76 and 1.13 liter respectively. The D2-40 is an in-line four cylinder engine with a total swept volume of 1.51 liter.

The D1-13 and D1-20 engines have identical pistons with the same dimensions. The D1-30 and D2-40 engines have different pistons, but of common dimensions.

The engines are lubricated by a pressure lubrication system, in which an oil pump supplies oil under pressure to all lubrication points.

Fresh water cooling uses a thermostatically controlled sea-water cooled heat exchanger. The sea water pump is operated by a gear train.

The crankshaft operates the coolant pump and alternator via a drive belt.

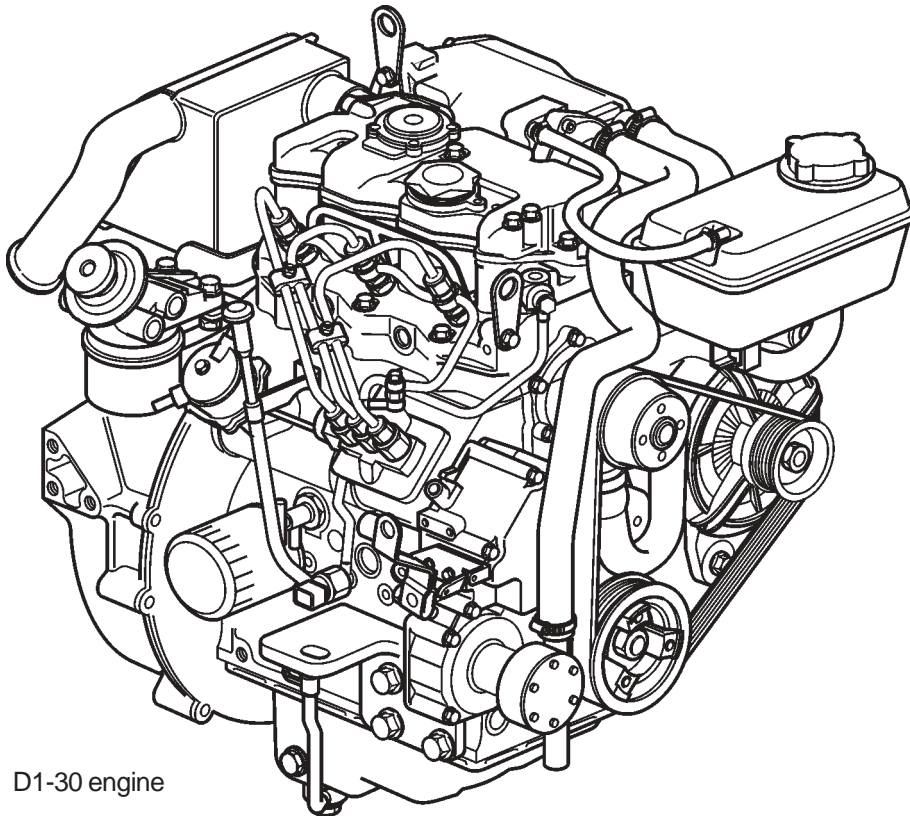

D1-30 engine



D1-13 A with MS10A reversing gear

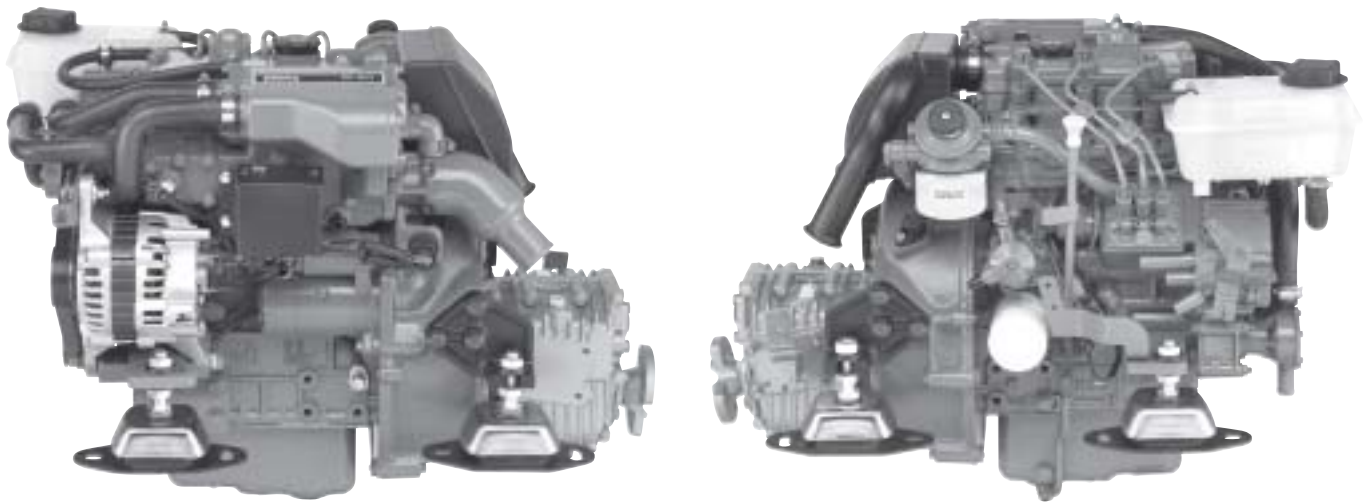

D1-20 A with MS10A reversing gear

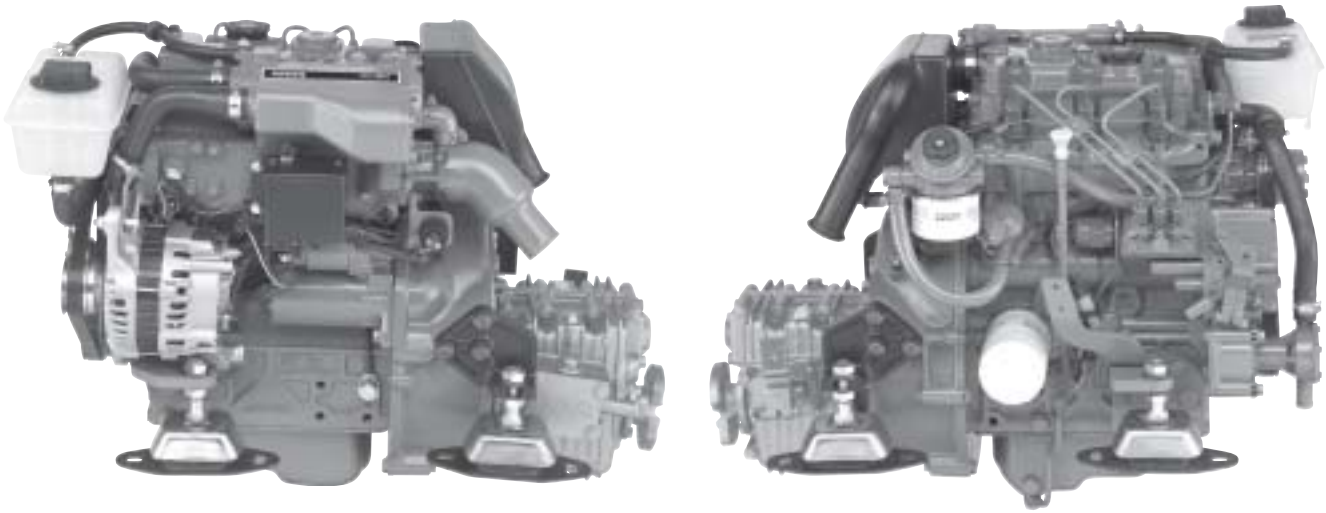

D1-30 A with MS15A reversing gear

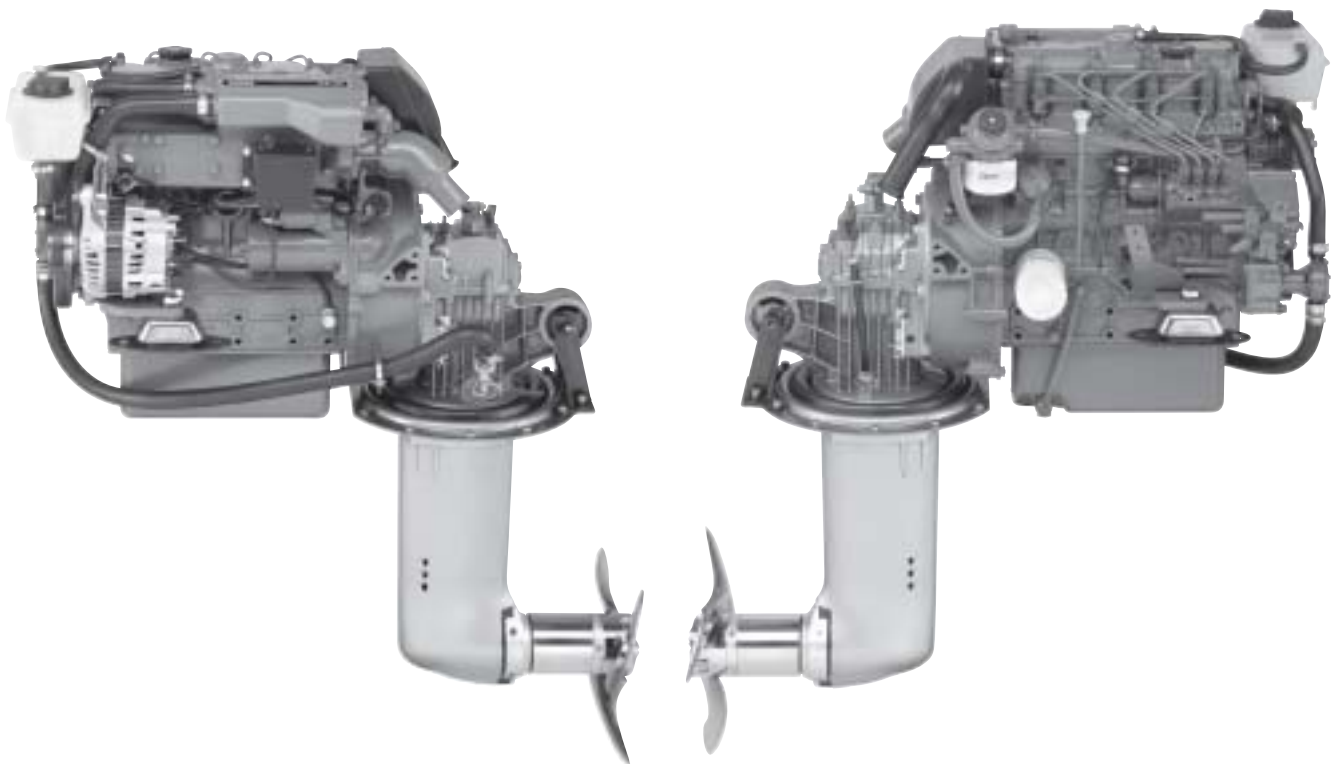

D2-40 A with 130S sailboat drive

Location of information decals and type plates

There are type plates on the engine and transmission, marked with identification numbers. This information must always be used as a reference when spare parts are ordered. The appearance and location of the type plates is shown below. The figures in brackets refer to the location of the identification number on the type plate.

Engine

- Product designation (1)
- Serial number (2)
- Product number (3)
- Certification number (4)

S - drive/Reversing gear

- Product designation (5)
- Serial number (6)
- Product number (7)
- Gear ratio (8)
- Propeller designation

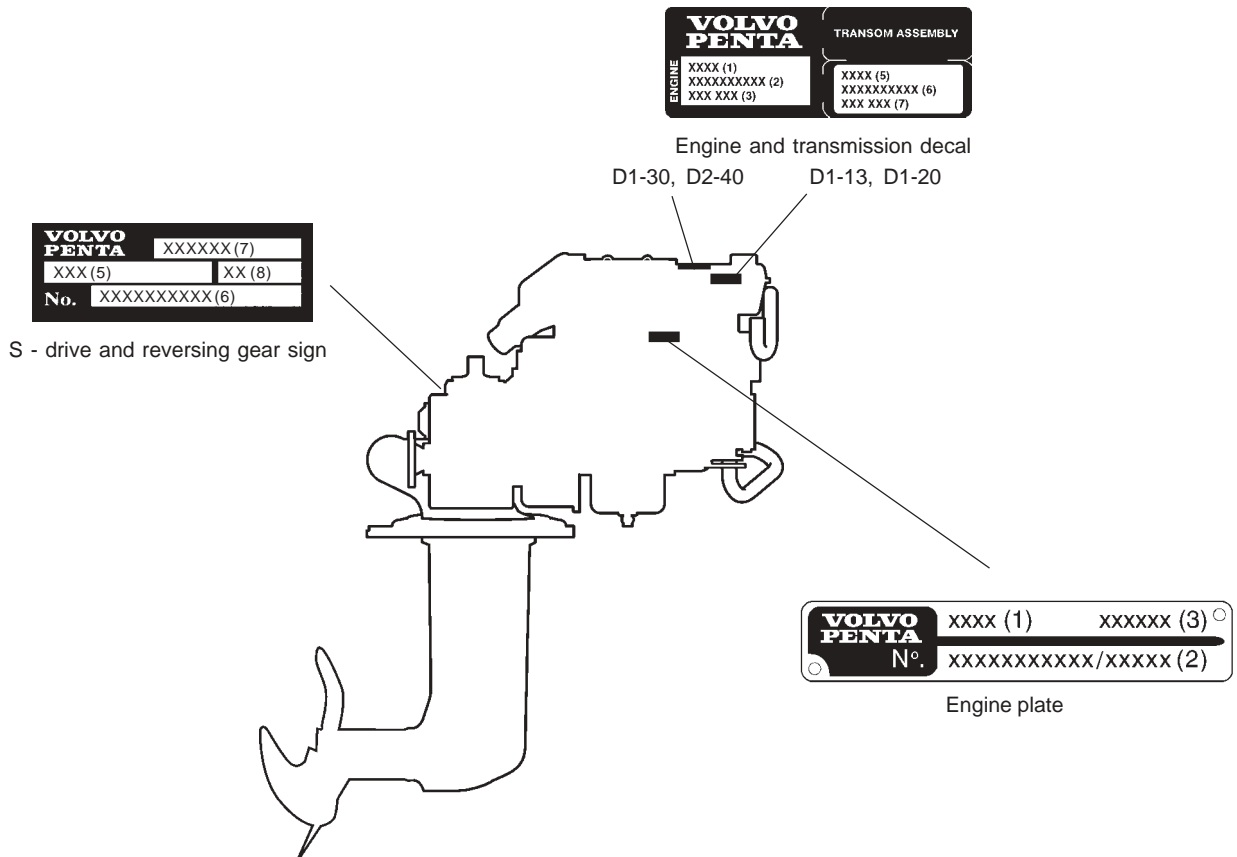

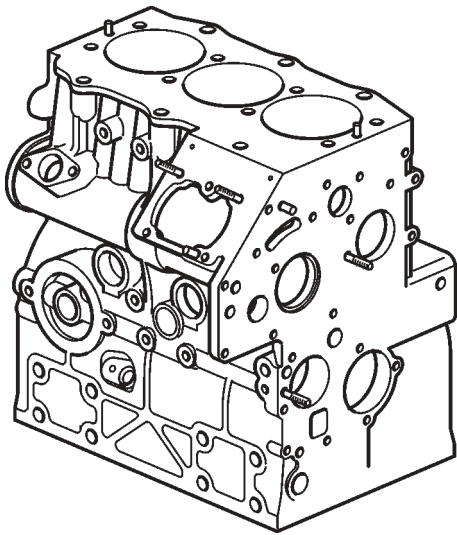

Engine block

The engine block is cast in one piece, from specially alloyed cast iron. The camshaft is located in the engine block.

The D1-13 has two cylinder bores, the D1-20 and D1-30 have three and the D2-40 has four.

The D1-13 and D1-20 have the same dimension per cylinder. The D1-30 and D2-40 have a larger, common dimension per cylinder.

None of the engines have cylinder liners. The cylinder walls are machined directly in the engine block.

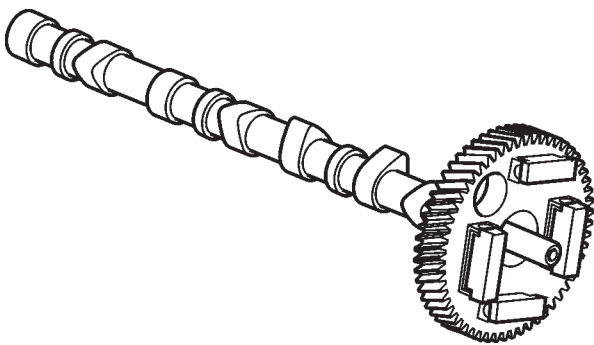

Sump

The sump is located under the engine block and is made from pressed sheet metal. There is an oil drain pipe under the sump.

Camshaft

The camshaft has lobes which operate the valves, the fuel pump and the injection pump. The camshaft is driven by the crankshaft and gear wheels, via the oil pump gear wheel.

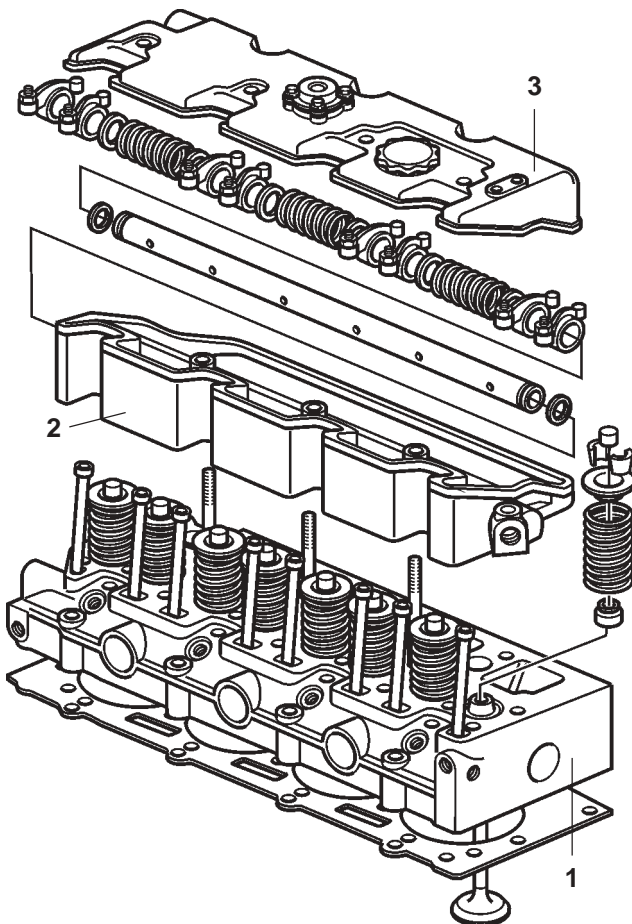

Cylinder head

The cylinder head (1) is made from specially alloyed cast iron.

The cylinder head has one inlet and one exhaust valve per cylinder. These are operated by the camshaft via valve lifters and push rods. The valves have replaceable seats.

An injector is installed in the combustion chamber of each cylinder. There is one glowplug per cylinder.

Rocker arm cover

The rocker arm cover (2) is made of aluminum and is located above the cylinder head. The valve mechanism is installed underneath the cover. Pressurized lube oil passes via an external pipe to the rocker arm shaft, and then lubricates the rocker arms and valves.

Valve cover

The valve cover (3) is made of aluminum and is located above the rocker arm cover. The valve cover has two internal sections, of which one leads inlet air down into the cylinder head via an inlet. The other section contains the crankcase ventilation valve.

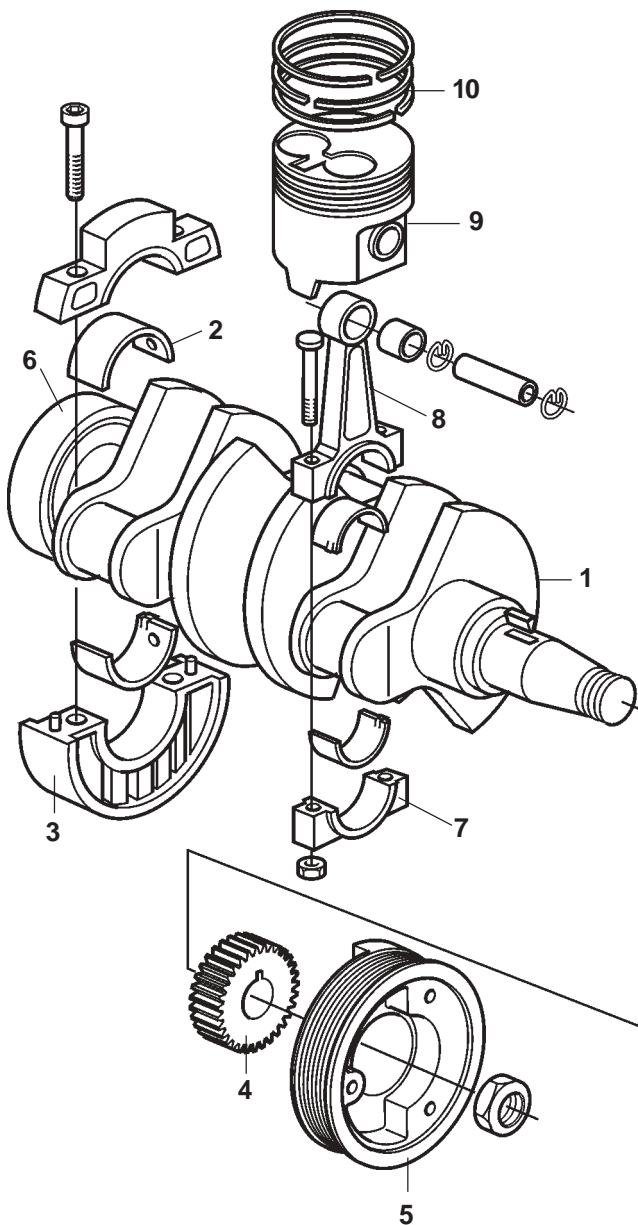

Crankshaft

The crankshaft (1) is supported by main bearings (2). The thrust bearing is integrated in the rear main bearing cap (3). The crankshaft is statically and dynamically balanced, and has induction hardened bearing surfaces. At the front end, where the gear wheel (4) for the timing gear and the pulley (5) for the alternator and coolant pump are located, the crankshaft has a groove for a Woodruff key. At the rear of the crankshaft, there is a flange (6) to which the flywheel is attached.

Main and big end bearings

The main and big end bearings (7) consist of steel-shells lined with bearing metal. The bearings are precision made and are ready to be installed.

Con rods

The con rods (8) have an I-section. The small end is drilled for gudgeon pin lubrication.

Pistons

The pistons (9) are made of light metal alloy. They have three piston rings (10). Two piston rings are compression rings and one is an oil scraper ring.

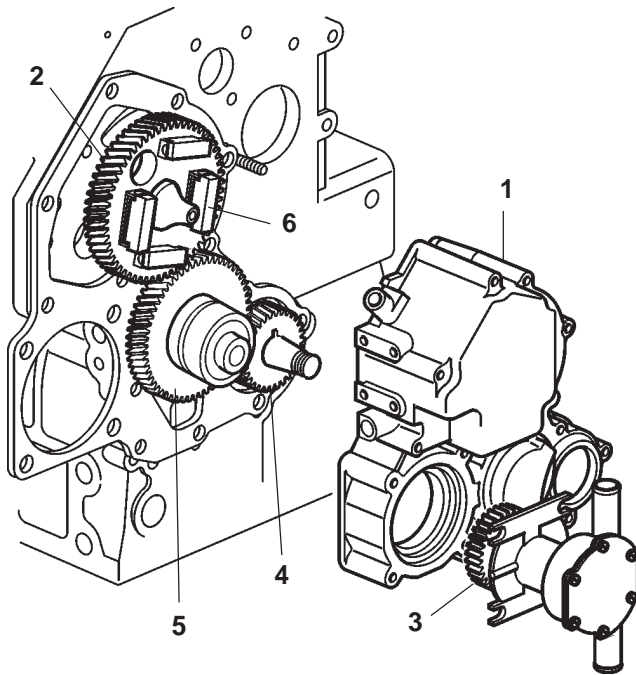

Timing gear

The timing gear consists of cylindrical gear wheels with helical teeth, located at the front of the engine block. A timing gear cover (1) provides complete protection for the timing gear.

The camshaft (2) and sea water pump (3) are driven by the crankshaft gear (4), via an idler wheel (5). The engine's lubrication pump is integral with the idler gear, and is driven by it. The regulator weights (6) are hung at the front of the camshaft drive and adjust the injection pump via a mechanism in the timing gear cover.

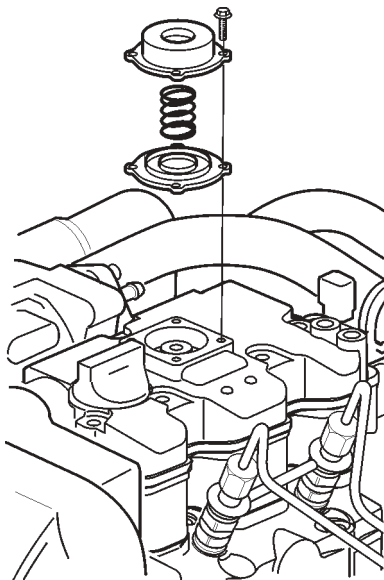

Crankcase breather

The crankcase ventilation is sealed and pressure controlled with a valve and spring located in the valve cover. When the gas pressure is higher, the valve opens and directs the crankcase gases into the inlet section, for combustion in the cylinders.

Group 22 Lubrication system

Lubrication oil system

The engines are provided with a complete pressure lubrication system. The lube oil pump is a gear wheel pump, and is driven by the crankshaft. The lube oil is lead through an external pipe to the valve mechanism.

The lube oil system has a reduction valve which limits the maximum oil pressure in the engine.

The oil filter is a full-flow filter, with bypass valve.

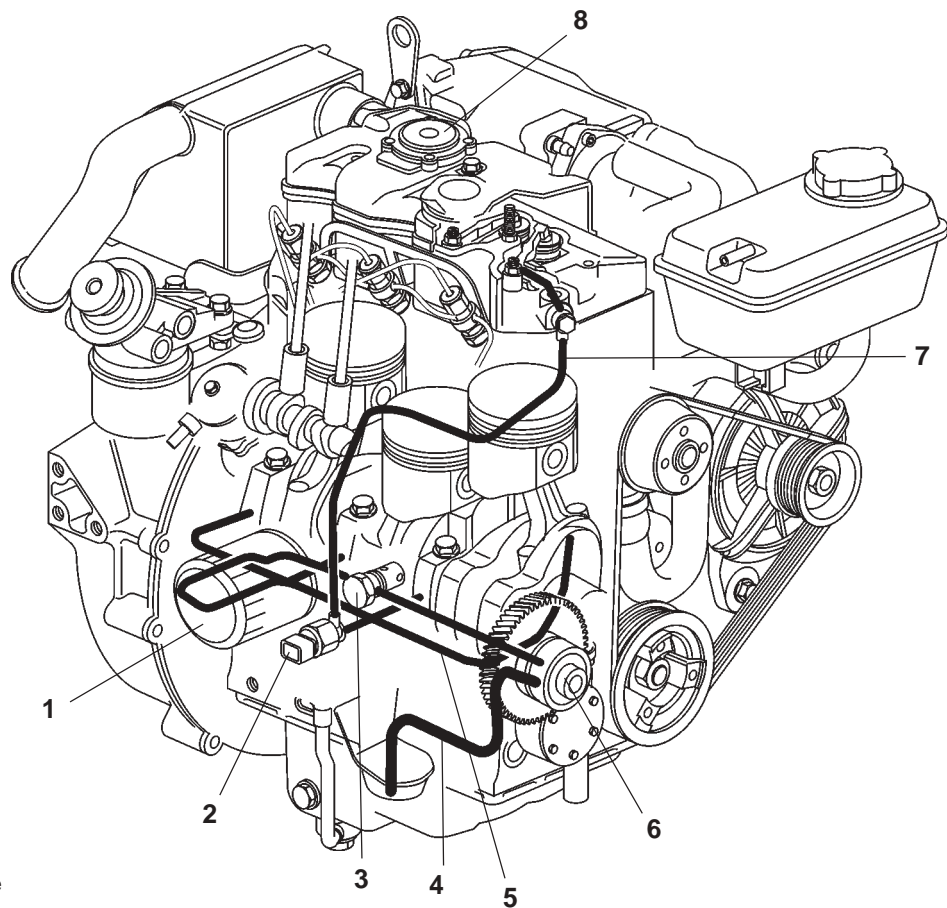

1. Oil filter
2. Oil pressure monitor
3. Pressure reduction valve
4. Inlet pipe with strainer
5. Main oil duct
6. Oil pump
7. Oil supply pipe (outer) to valve mechanism
8. Crankcase ventilation, valve

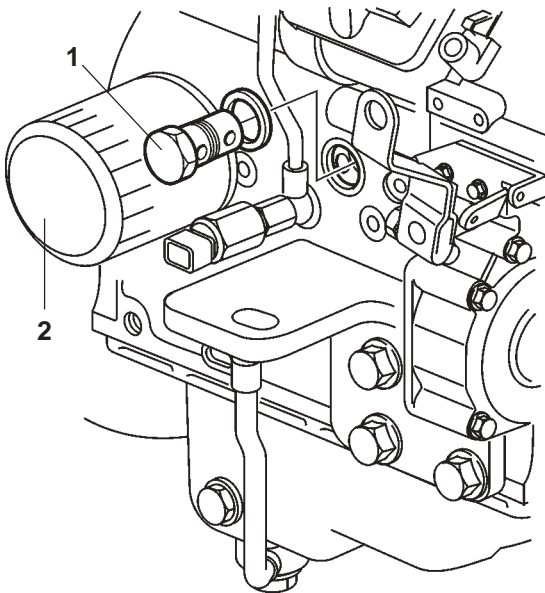

Oil valves

The lubrication pressure is limited by a reduction valve (1). The valve is installed in the lubrication system, just upstream of the oil filter (2). The valve opens at high pressure and allows the oil to flow back into the sump.

The D1-13 and D1-20 engines have a reduction valve which opens in the interval from 352-448 kPa. On the D1-30 and D2-40 engines, the valve opens in the interval from 304-500 kPa.

A bypass valve located on the oil filter opens if the resistance in the filter rises abnormally high. Oil supply to the lubrication points is ensured in this way, even if the filter is blocked, but the oil is no longer cleaned.

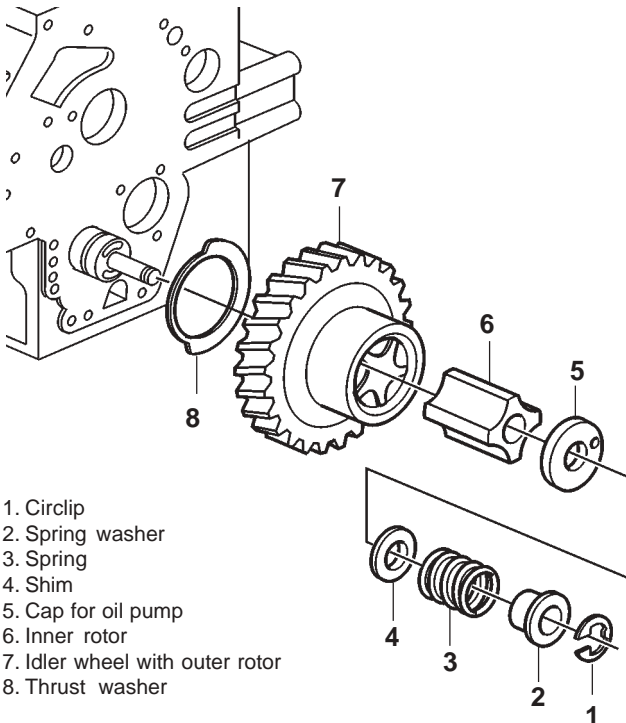

Oil pump

The lube oil pump is located in the idler wheel in the timing gear, which also drives it.

The pump is a rotor pump, with an inner rotor and an outer rotor, eccentrically mounted in relation to each other. The inner rotor has one "tooth" less than the outer rotor.

The function of the pump is that the volume of the spaces between the inner and outer gears increases and reduces. During the first section of the rotation of the inner rotor, the volume increases, a partial vacuum occurs and oil is sucked into the inlet. After about a half rotation, the volume is reduced and a pressure occurs, which forces the oil out through the outlet.

- 1. Circlip
- 2. Spring washer
- 3. Spring
- 4. Shim
- 5. Cap for oil pump
- 6. Inner rotor
- 7. Idler wheel with outer rotor
- 8. Thrust washer

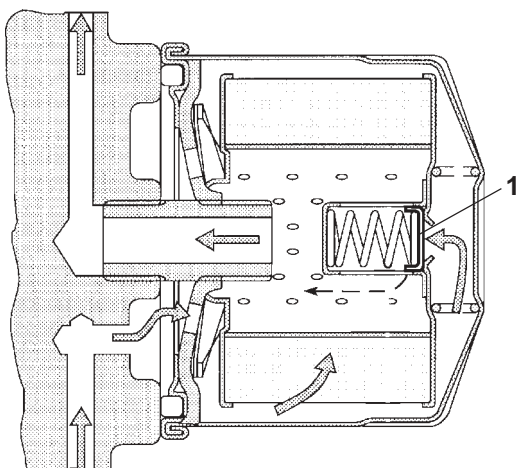

Oil filter

The purpose of the oil filter is to remove contamination from the oil. The filter is a full flow filter, which means that all the oil is filtered before it is forced out into the lubrication system.

Filter insert is a folded paper filter.

There is a bypass valve (1) at the base of the filter, which opens and allows oil to flow past the filter if the filter insert should become blocked.

When the filter has been in use for a pre-determined time, it must be replaced by a completely new filter.

Group 23 Fuel system

Fuel system

A mechanical feed pump sucks the fuel up from the fuel tank, possibly through a water separation filter (optional equipment), and the fuel is then forced through the secondary filter to the injection pump.

The injection pump, which is driven by the camshaft, then distributes fuel of specific quantity and timing to the injectors.

Fuel which returns from the injectors is returned to the base of the fuel tank. The air in the fuel system can be transported back to the fuel tank via a connection between the injection pump and the return fuel pipe.

The fuel is then forced through the injector nozzles into a pre-combustion chamber in the cylinder head at high pressure and then enters the combustion chambers in the pistons, where high speed air rotation contributes to even combustion. A glowplug in the pre-combustion chamber pre-heats the fuel mixture for cold starting.

The secondary filter in the engine removes contamination which might be left in the fuel, despite the primary filter.

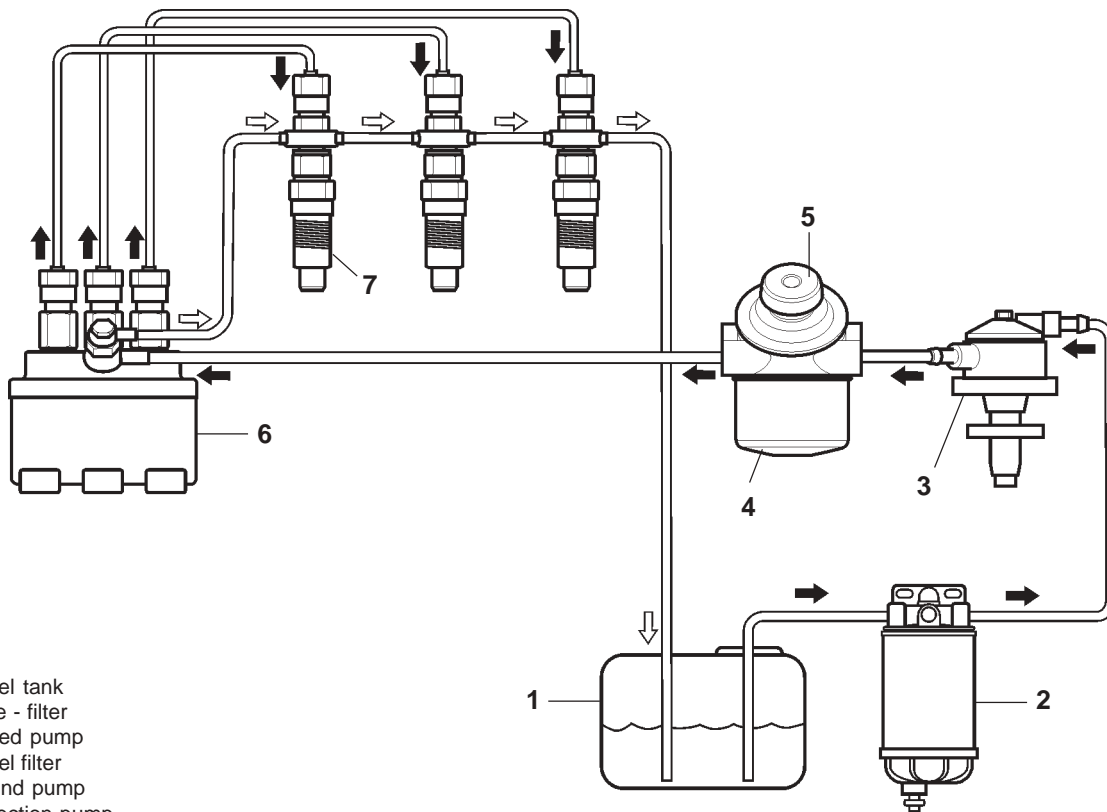

1. Fuel tank
2. Pre - filter
3. Feed pump
4. Fuel filter
5. Hand pump
6. Injection pump
7. Injectors

Injection pump

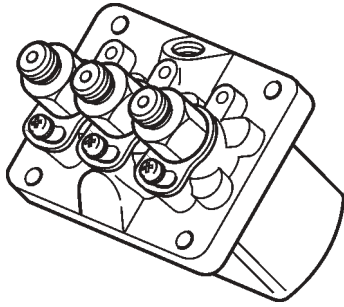

The injection pump is a flange-mounted in-line pump which is located on the engine block. The pump is driven by cams on the engine's camshaft, which operates the pump chambers directly.

The injection pump has the same number of pump pistons as the engine has cylinders.

Centrifugal regulator

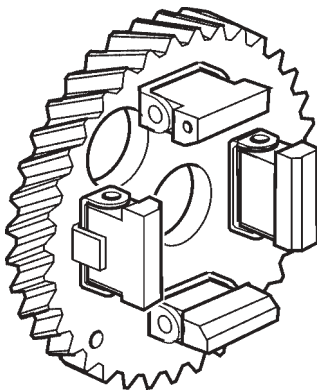

The regulator is mechanical, and uses regulator-weights for engine speed sensing. It is mounted on the front of the camshaft gear, which also drives it.

The regulator weights operate the injector pump control rod via the regulation sleeve, a lever and a regulator arm. Engine speed is regulated across the engine's entire speed range, from low idle to high idle (all speed type).

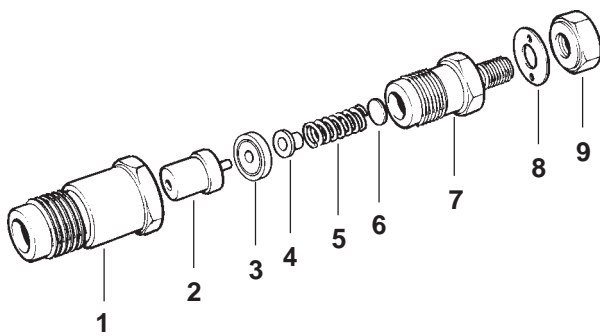

- | | |
|----------------------|-----------------------|
| 1. Injector nut | 6. Adjustment washers |
| 2. Injectors | 7. Injector holder |
| 3. Joining piece | 8. Washer |
| 4. Compression screw | 9. Nut |
| 5. Spring | |

Injectors

The engines is provided with pintle - type injectors. Each injector basically consists of a nozzle retainer and a nozzle.

When the fuel pressure increases to the set value (opening pressure), the injector needle which is held pressed against its seat by the compression spring is lifted and atomized fuel is injected into the precombustion chamber of the engine.

The injector opening pressure is determined by the compression spring tension, which is adjusted by adjustment washers.

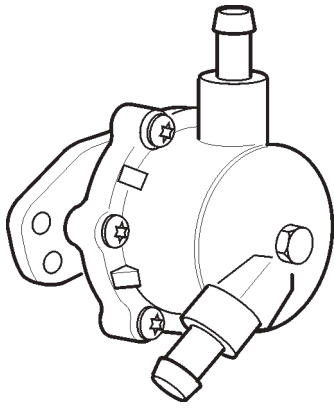

Feed pump

The feed pump is mounted on the outside of the engine block and is driven by an eccentric on the rear of the camshaft.

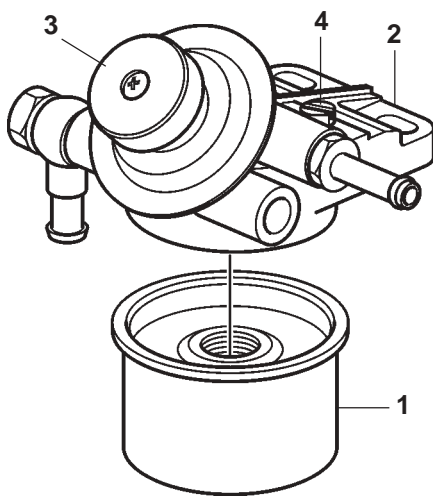

Fuel filter

The fuel filter (1) is of the disposable type. The filter insert is a paper filter.

The fuel filter is located in a bracket (2) together with a hand pump (3) and vent screw (4).

Group 26 Cooling system

General

The engine is fresh water cooled and has a sealed cooling system with expansion tank. The system is subdivided into two circuits.

In the inner circuit, the fresh watersystem, the coolant is circulated by a coolant pump which is driven via a belt from the crankshaft pulley.

The fresh water circuit operates under a certain amount of excess pressure, which reduces the risk of boiling if the temperature rises too high. If the pressure becomes higher than normal, a pressure valve opens in the filler cap on the expansion tank.

The coolant temperature is regulated by a thermostat. When the engine is cold, a thermostat directs the coolant round an internal circuit in the engine. When operating temperature begins to be reached, the coolant is progressively directed out through the entire heat exchanger, where the surplus heat is removed.

In the outer circuit, the sea water system, sea water is forced through by a gear-wheel driven pump with rubber impeller.

The sea water system cools the engine's heat exchanger. The sea water is returned together with the exhaust gas, via a connection in the exhaust bend.

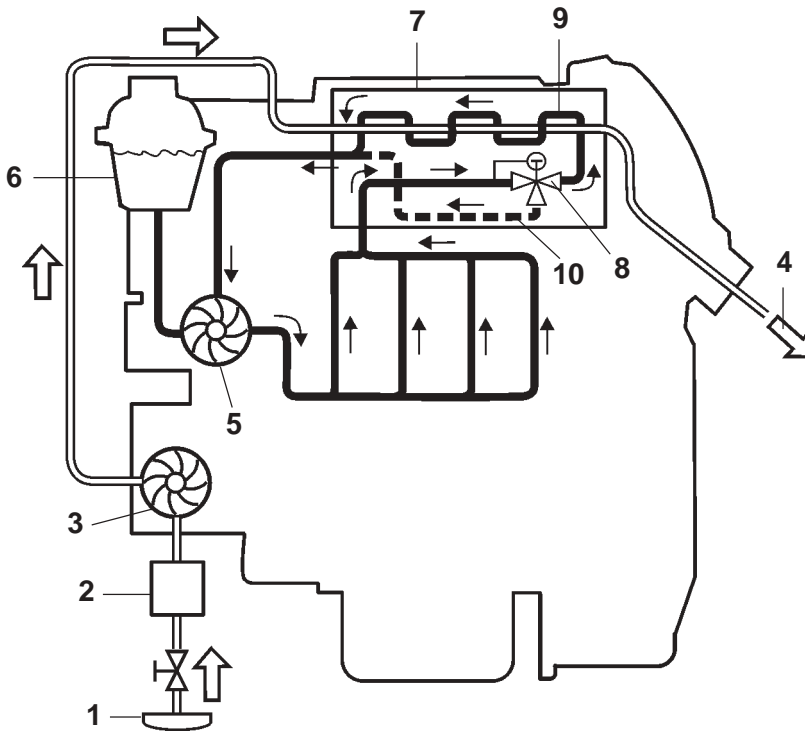

1. Sea water, inlet
2. Sea water filter
3. Sea water pump
4. Seawater, outlet
5. Coolant pump
6. Expansion tank
7. Heat exchanger/exhaust manifold
8. Thermostat
9. Open thermostat - circulation
10. Closed thermostat - circulation

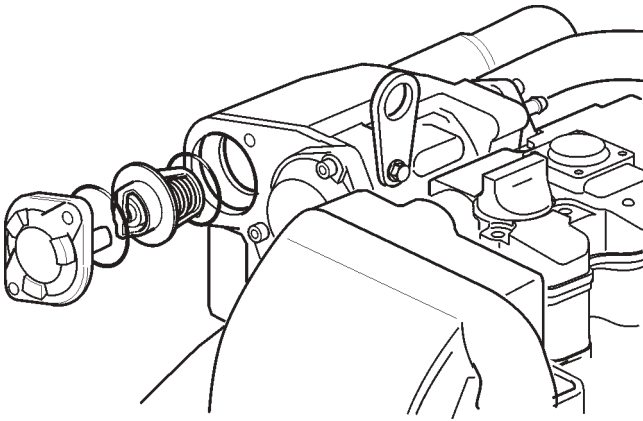

Thermostat

The engine is equipped with a thermostat whose sensor body contains wax.

When the engine is cold, the thermostat keeps the path to the heat exchanger closed. Coolant then passes through a by-pass pipe, back directly to the suction side of the pump. As the engine warms up, the volume of the wax increases and the thermostat progressively opens the passage to the heat exchanger, at the same time as the by-pass channel is closed.

Please refer to the "Technical Data" chapter for opening temperatures.

The thermostat is located in a housing which is integrated in the heat exchanger and exhaust manifold.

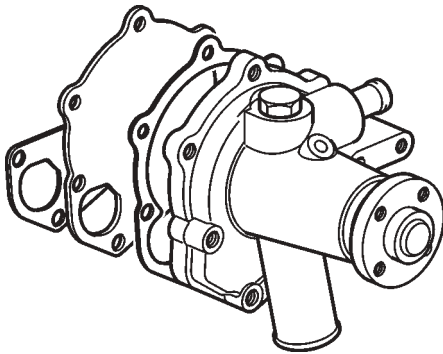

Coolant pump

The coolant pump is mounted on the engine block and is driven by the crankshaft by means of a drive belt.

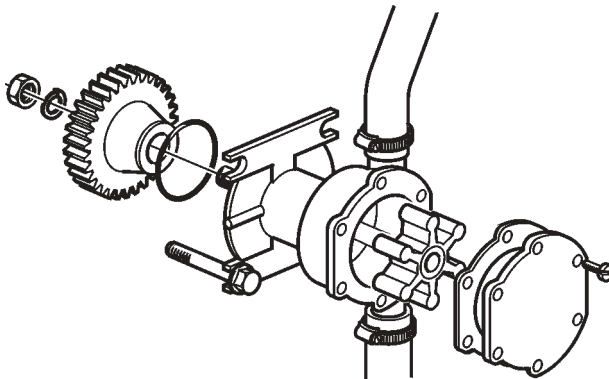

Sea water pump

The sea water pump is a rubber impeller type pump, and is mounted on the front of the engine. The pump is driven from the engine's timing gear system and forces cooling water out to the heat exchanger on the engine.

The impeller (pump wheel) is made of rubber, and is replaceable.

NOTE! The impeller will be damaged if the pump is run dry.

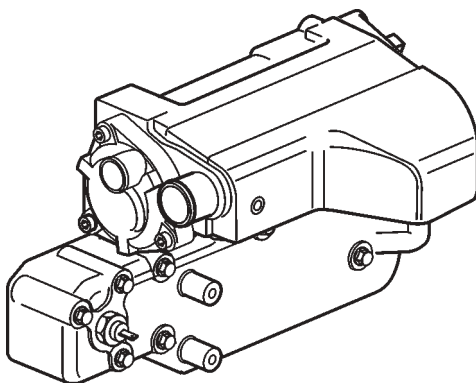

Heat exchanger

The heat exchanger is located in a housing which is integrated with the exhaust manifold and thermostat.

Sea water passes through the heat exchanger matrix and transfers heat from the internal cooling circuit in the engine (fresh water system) to the outer circuit (sea water). When the thermostat has not yet opened, the coolant is lead through a short, uncooled passage in the heat exchanger and back to the engine.

Group 30 Electrical system

General

The engines have an alternator which supplies electric current of 115 A. System voltage is 12 V and the electrical system is single-pole.

The electrical system contains sensors for monitoring the engine coolant temperature and oil pressure. A distribution box contains a circuit breaker, and there are two relays under the heat exchanger.

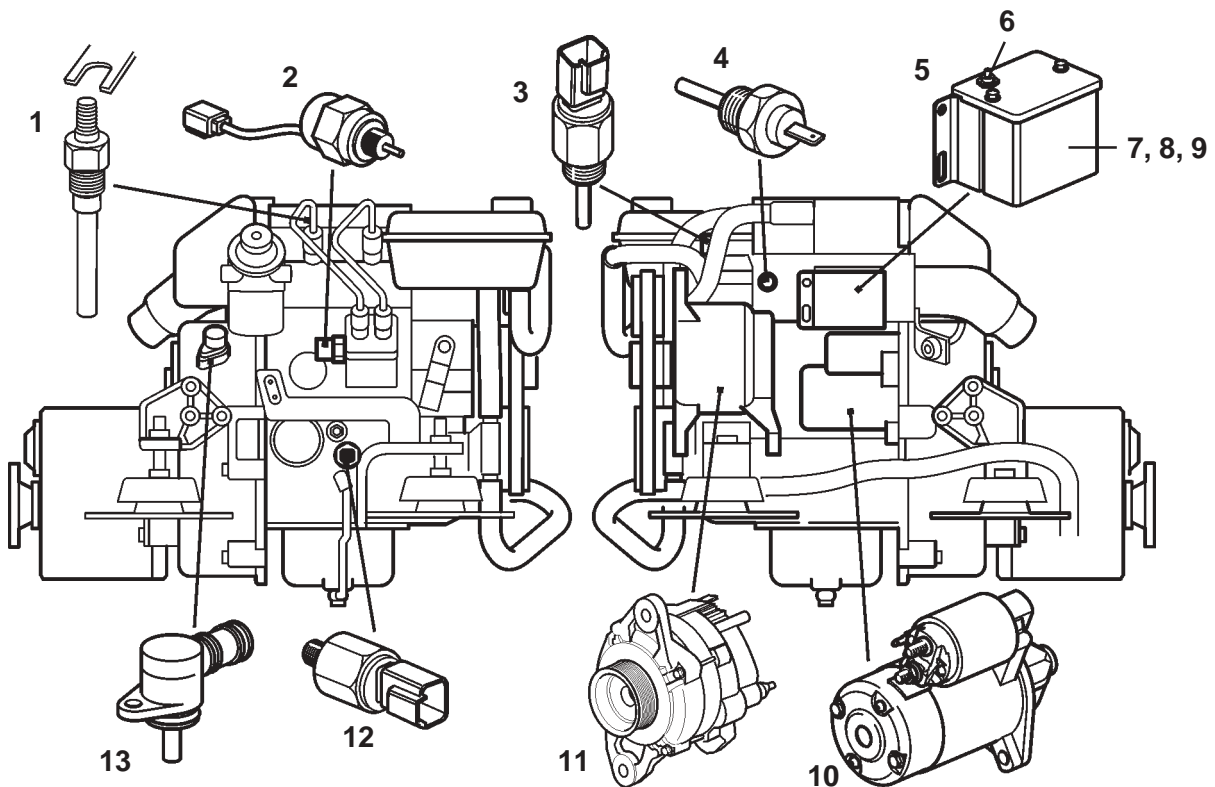

1. Glow plugs
2. Stop solenoid
3. Coolant temperature monitor
4. Coolant temperature sensor
5. Distribution box
6. Circuit breaker
7. Starter relay
8. Glowplug relay
9. Charge sensing resistor
10. Starter motor
11. Alternator
12. Oil pressure monitor
13. Engine speed sensor

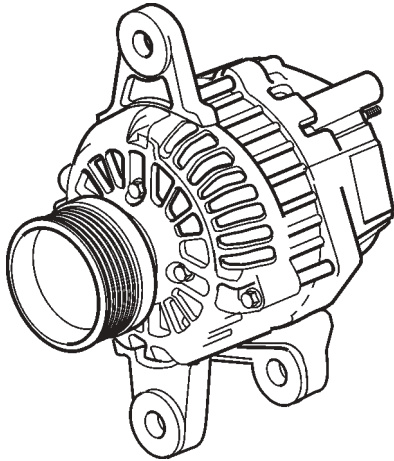

Alternator

The alternator provides alternating current (14V/115A).

The voltage regulator on the alternator is provided with a sensor system.

The sensor system compares the charge voltage between the alternator terminals, B+ and B-, with the voltage across the battery positive and negative terminals. The voltage regulator then compensates for any voltage drop in the cables between the alternator and the batteries, by increasing the charge voltage supplied by the alternator as necessary.

When delivered from Volvo Penta, the sensor system is not activated. The connection has probably been done during engine installation, however.

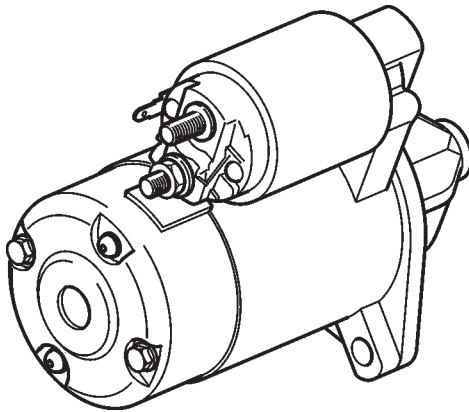

Starter motor

The starter motor is a DC series motor. The starter pinion is operated by a control solenoid and can be slid axially on the rotor shaft.

The starter motor has a reduction gear, which makes it possible to obtain greater torque.

The starter motor power depends on the engine it is fitted to, please refer to the table below.

D1-13, D1-20	0.8 kW
D1-30	1.1 kW
D2-40	1.4 kW

Distribution box

Circuit breaker

A 16 A circuit breaker protects the electrical system and cuts the current if overloaded.

If it has tripped, the electrical system is re-connected by pressing the button on the circuit breaker in the distribution box. Always first investigate the reason for the overload.

Relays

The starting and glowplug functions are each controlled by a switching relay. These relays are identical and are thus mutually interchangeable. They are located in the distribution box.

Charge sensing resistor

The charge sensing resistor has a value of 33 Ohm/ 9 W.

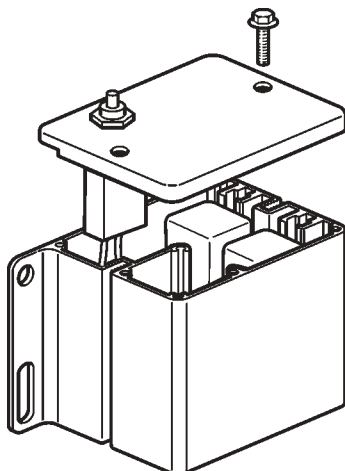

Electrical components

Lube oil pressure monitor - alarm

Contact type: Normally open. The contacts close if the lube oil pressure in the engine falls below 0.5 ± 0.15 bar.

The closing pressure should be checked with **falling** pressure.

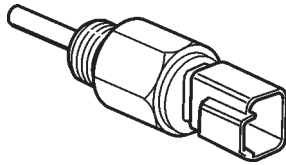
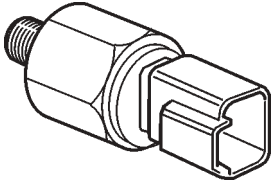

Coolant temperature monitor - alarm

Contact type: Normally open. The contacts close if the coolant temperature exceeds:

D1-13, D1-20	$105^{\circ}\text{C} \pm 2^{\circ}\text{C}$
D1-30, D2-40	$110^{\circ}\text{C} \pm 2^{\circ}\text{C}$

The switching point should be checked with **rising** temperature.

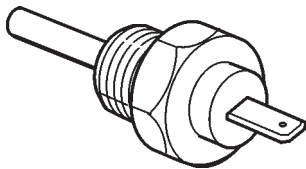

Coolant temperature sensor

Resistance testing, measured with the sensor immersed down to the hex head screw for three minutes in circulating fluid, with system current connected.

Temp. 60°C :	$134.0 \pm 13.5 \Omega$	$(\pm 4^{\circ}\text{C})$
90°C :	$51.2 \pm 4.3 \Omega$	$(\pm 4^{\circ}\text{C})$
100°C :	$38.5 \pm 3.0 \Omega$	$(\pm 4^{\circ}\text{C})$

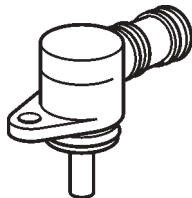

Engine speed sensor

The sensor is located on the flywheel housing and uses inductance to give engine speed information which changes with the speed of the engine.

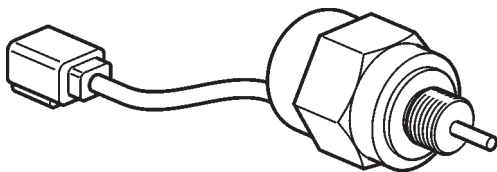

Stop solenoid

The stop solenoid is an electrical stopping device which shuts off fuel supply at the injection pump.

Glow plugs

One glowplug per cylinder is installed in the cylinder head. All glowplugs are electrically connected by a busbar.

The glowplugs heat the fuel mixture during starting.

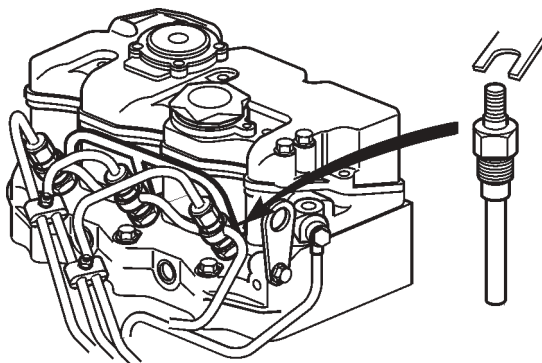

Repair instructions

Group 21 Short block

General

A condition test should be done before each major service activity, if possible, to determine the general condition of the engine and discover any concurrent fault causes. A condition test requires the engine to be run, so this should be done before the engine or any engine components are disassembled.

Please refer to "Condition test, engine".

When working with chemicals, fuel and lubricating oil

⚠ IMPORTANT! Always use protective gloves for work which includes contact with oil, fuel etc.

Constant skin contact with engine oil can be very harmful.

Before working in a boat

- 1 Turn the main switch off.
- 2 Clean the outside of the engine.

NOTE! Make sure that wash residue is collected for destruction and does not inadvertently end up in the water. Also refer to the warning text under "Actions after lifting the engine".

- 3 The work includes the following actions on the cooling system: Close the sea cocks and drain the coolant from the sea water and fresh water systems.

⚠ WARNING! Make sure that all sea water inlets are securely closed, so that water can not find its way in during disassembly of cooling system sub-components.

Before lifting the engine

Boat removed from the water

- 1 Turn the battery isolator off, undo the battery connections on the starter motor.
- 2 Remove the connector for the engine cables to the instruments.
- 3 Remove the sea water connections/cool keeling connection.
- 4 Remove the exhaust pipe.
- 5 Close the fuel taps. Remove the fuel connections.
- 6 Remove the throttle and gear shift cables.
- 7 Undo the propeller shaft from the reversing gear. Undo the engine mounting pads from the bed and lift the engine out. Use the lifting lugs (1) on the engine.

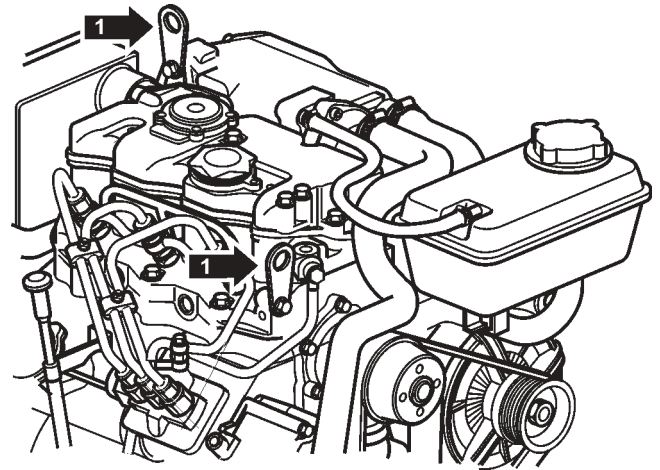

Actions after lifting the engine

- 1 Clean the engine.

⚠ IMPORTANT! Remember the following when washing with a power washer: Be extremely careful when cleaning, to avoid getting water inside engine components. When a power washer is used, the water jet must never be aimed at seals, such as shaft seals, joints with gaskets, rubber hoses or electrical components.

- 2 Drain the engine oil.
- 3 Remove the reversing gear (as necessary).

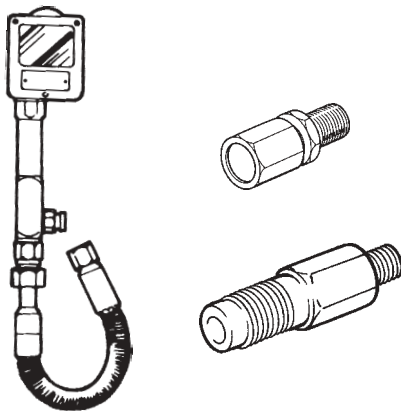

Flat Rate: 21035

Condition test, engine

Compression test

Special tools: 885 252, 885 484, 998 8539

A compression test is done, which shows the sealing of the cylinders and valves, to assess the condition of the engine in a simple, reliable manner.

- Warm the engine up, then stop it.
- Remove all the injectors and test each of the cylinders in turn.

⚠ IMPORTANT! Observe the greatest possible cleanliness, to avoid getting dirt in the fuel system. Plug the connections for the disassembled injectors and fuel pipes.

The compression pressure must be read at normal starter motor speed.

Low combustion pressure in all cylinders indicates worn cylinder bores and piston rings. If one cylinder has lower compression pressure than the others, the reason can be poor valve sealing, broken piston rings or a damaged cylinder head gasket.

Insert adapter nos. 885 484 and 885 252 in the injector hole.

Install a compression gauge 998 8539 in the adapter, and carry out the compression test.

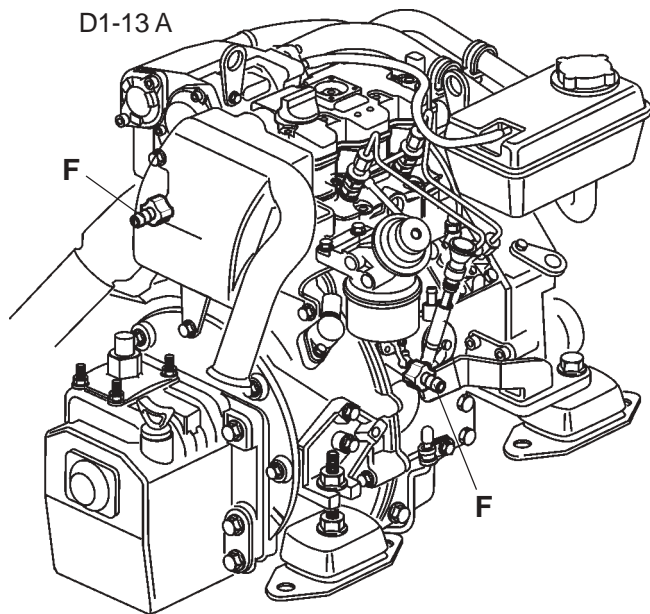

F = Fresh water drain tap

Cooling system, draining

NOTE! Remove the expansion tank filler cap and close the hull fitting before draining the cooling system.

⚠ WARNING! Open the pressure cap very carefully if the engine is hot. Steam or hot coolant can spray out and cause burns.

1

Connect drain hoses to the taps on the fresh water system. Open all drain points.

The sea water system is drained by undoing hoses at the lowest points of the system.

2

Check that all water drains out.

Check whether the installation has any further taps or plugs at the lowest points of the cooling water pipes and exhaust pipe.

3

Close the taps.

4

Pump the bilges out as necessary. Check that no leakage occurs.

Engine oil, draining/changing

Hot engine

1

Connect the suction pipe on the oil drain pump to the oil drain pipe.

Suck the oil into a suitable vessel. The oil can also be drained after the sump drain plug has been removed.

Engine fixture, fixing

Drained cooling system and engine oil. Engine removed. Right front engine mounting removed.

Special tools: 885 224, 999 9737

Use fixture 885 224 and 999 9737 to fix the engine to engine stand 998 6485. Only fixture 885 224 is needed for fixing to engine stand 999 2520.

Screw the fixture to the right side of the engine, as in the illustrations.



D1-13-A

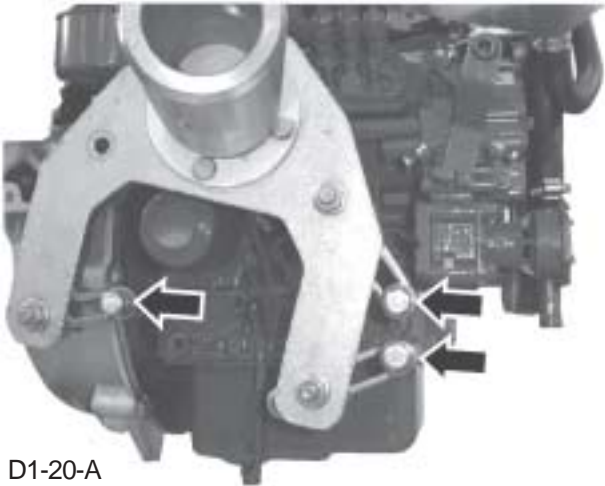

D1-20-A



D1-30-A



D2-40-A

Short block, disassembly

Empty the oil and water out of the engine. Lift the engine with a suitable lifting device. Installing the engine fixture, please refer to "Engine fixture, fixing".

⚠ WARNING! Observe the greatest possible cleanliness in work on the fuel system. Watch out for fuel spillage, diesel oil is hazardous on repeated skin contact.

⚠ IMPORTANT! Observe the greatest possible cleanliness, to avoid getting dirt in the fuel system. Plug the unions in the fuel system with suitable protective plugs, such as kit no. 885510.

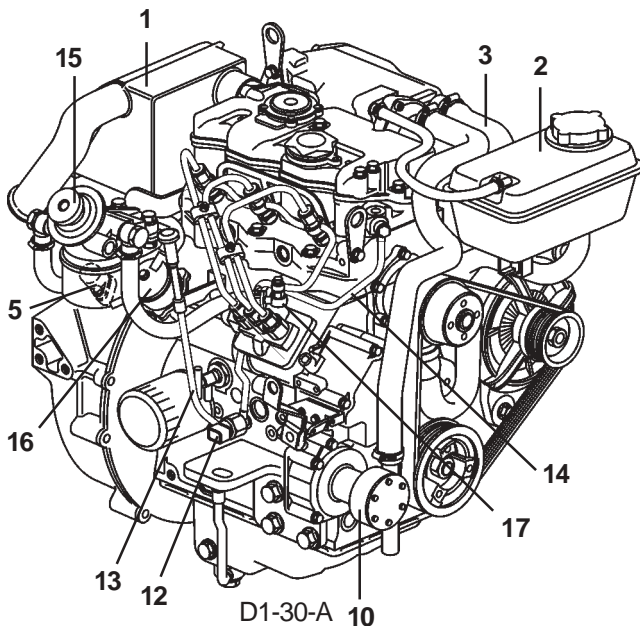

1. Remove the induction silencer (1).
2. Undo the expansion tank (2) and its bracket. Remove all coolant hoses (3) with brackets.
3. Remove the electronic box (4) complete with cable harness. Undo the engine speed sensor (5).
NOTE! Note the way that the cable harness is clamped before removing it.
4. Remove the alternator (6) with bracket, starter motor (7) and the left-hand engine mounting (8).
5. Remove the heat exchanger/exhaust manifold (9), sea water pump (10), coolant pump (11) with spacer (D1-13).
6. Remove the oil pressure monitor (12), dipstick (13) and oil pressure pipe (14) from the cylinder head.
7. Remove the fuel filter bracket (15) with anchorage, feed pump (16) and feed hose by the union (17) for the injection pump. Leave the fuel hoses between the fuel filter, feed pump and union in place.

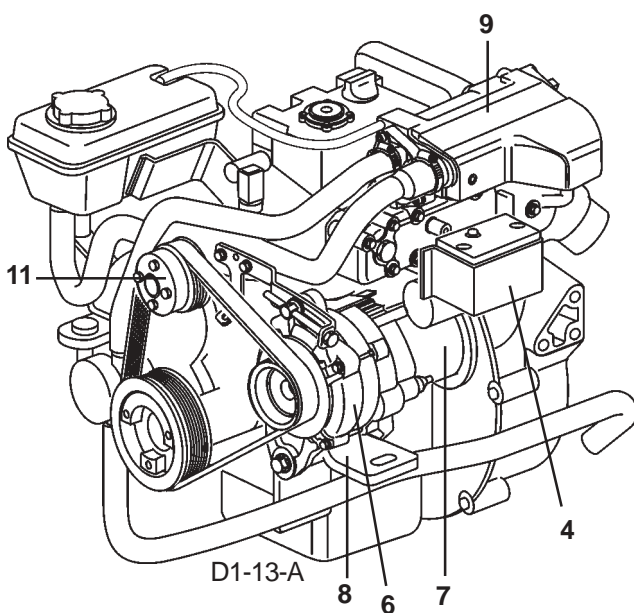

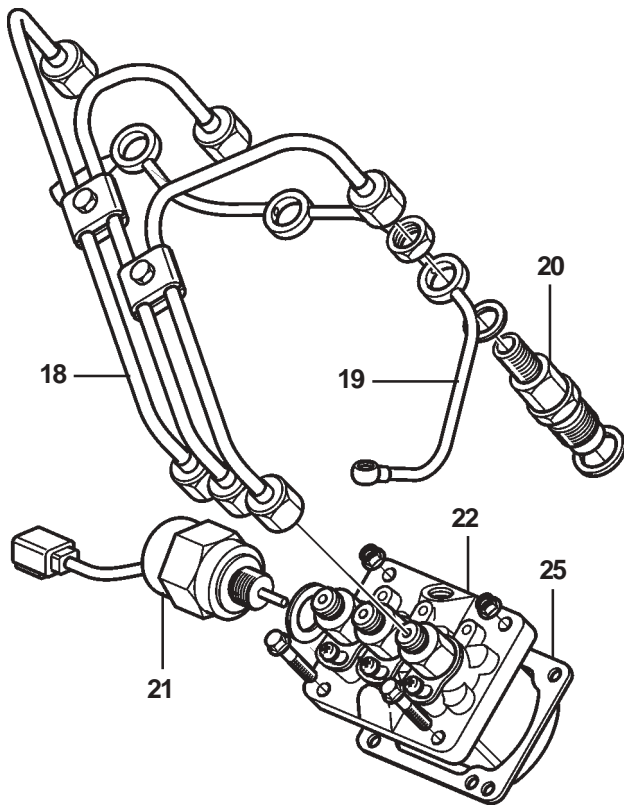

23 24

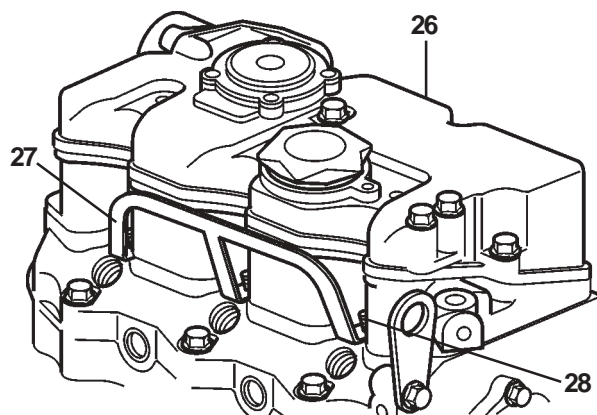

8. Remove the fuel supply pipes (18) between the fuel pump and injector, use the nut underneath the fuel return pipe to avoid kinking the pipe. Remove the fuel supply pipes and put them on a clean, dry surface.
9. Remove the return fuel pipe (19) and injectors (20).
10. Unscrew the stop solenoid (21). Remove the injection pump (22). Remove the fixing screws and nuts on the pump. Turn the stop lever clockwise and carefully lift the pump, to make the lock clip on the regulator arm accessible.
Remove the lock clip (23) and free the regulator arm (24).

⚠ IMPORTANT! Be careful when disassembling the injection pump, avoid damaging or bending its lever.

NOTE! Save the shim/gasket (25) beneath the injection pump flange. Use the same thickness of shims when re-installing, unless the camshaft, engine block or injection pump has been changed.

11. Remove the valve cover (26), bus bar (27) and glow plugs (28).

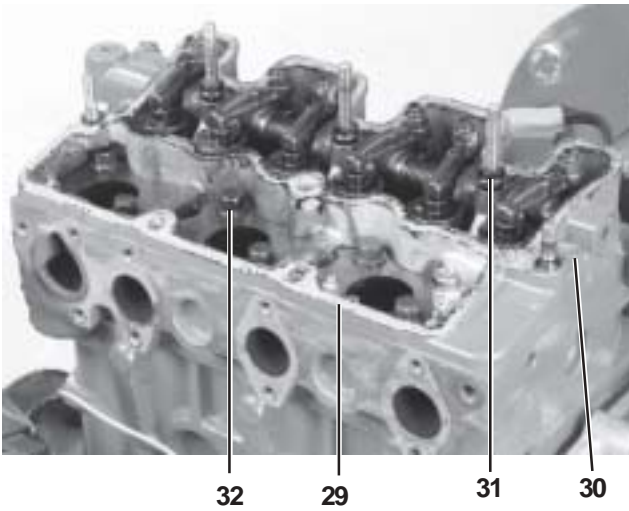

12. Remove the lower part of the valve cover (29) with the integrated rocker arm bridge. Start by unscrewing the two screws (30) on the edge, then undo the rocker arm bridge nuts (31) one turn at a time until the load on them has been relieved.

13. Prepare a stand, marked with cylinder numbers. If the valve caps, push rods and valve lifters are to be re-used, they **must** be put back in their original places.
Lift the push rods and valve caps out and put in them in number sequence in the marked stand.

17. Undo the screws (32) in the opposite sequence to when they are tightened, please refer to "Technical Data". Remove the cylinder head.

18. Remove the valve lifters out of the engine block with a magnetic pen, part no. 885 822. If the valve lifters are to be re-used, they **must** be put back in their original places.
NOTE! The D1-20 and D2-40 engines have some valve lifters which are chamfered off.

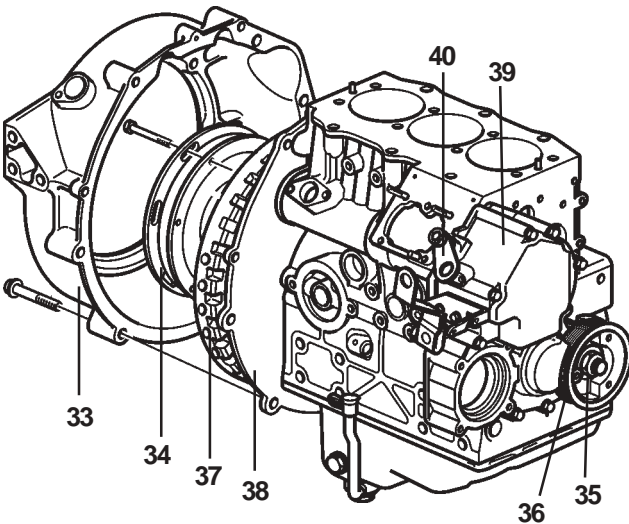

19. Remove the flywheel cover (33) and flexible coupling (34).

23. Undo the center nut (35) on the pulley. Remove pulley (36), use special tool 885 820. Use the flywheel as a counterhold. Remove the Woodruff key from the crankshaft.

20. Remove the flywheel (37).

22. Remove the inner flywheel housing (38) and rear crankshaft seal.

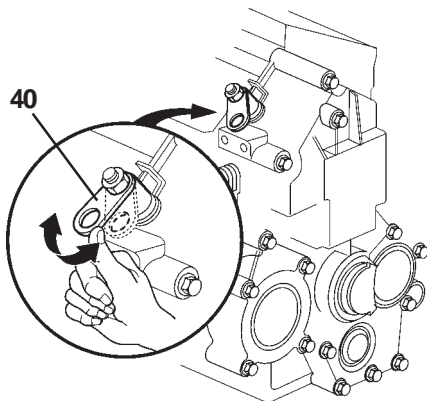

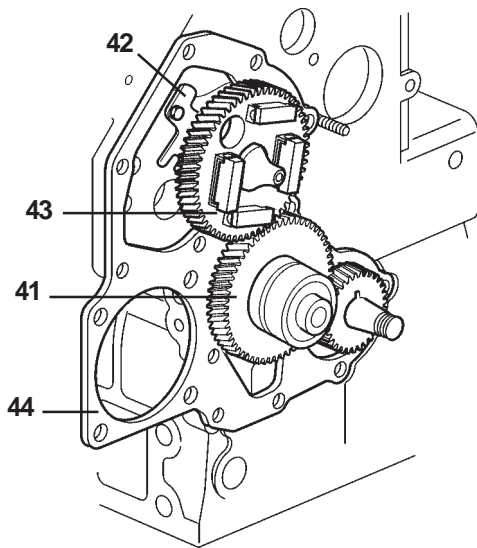

23. Remove the timing gear cover (39). Load the stop arm (40) so that the springs on the inside of the housing do not come out of position or spring out.

24. Remove the idler wheel (41) circlip. Save the sleeve washer, spring and shims.

Lift away the idler wheel, complete with cover and oil pump. Also remove the thrust washer behind the idler wheel.

25. Remove the locking plate (42) screws. The screws are accessible behind the holes in the camshaft gear.

Lift out the camshaft (43), complete with gear and regulator weights.

NOTE! Be careful to avoid damaging the bearings, bearing tracks and camshaft lobes.

26. Remove the timing gear plate (44) with gasket.

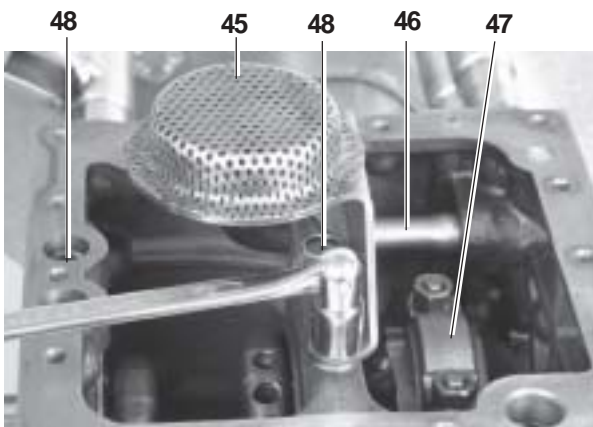

27. Turn the engine over and remove the sump, together with the external oilpipe. Remove the oil strainer (45) and oil suction pipe (46). Remove the oil pressure reduction valve.

28. Scrape away the line of carbon at the top of the cylinders, to facilitate removal.

Remove the big end bearing caps (47) and press the pistons out.

NOTE! Check the markings on the big end bearing caps.

29. Remove the locking screws (48) which hold the main bearing caps. Lift the crankshaft out carefully, complete with caps, backwards.

NOTE! Tape the crankshaft gear to protect the bearing surfaces in the block during disassembly.

Short block, inspection, component change, overhaul and assembly

Inspecting the engine block

Upper block plane

Check that the upper engine block plane does not have any cracks or other damage. Also check that it is not warped (in the same way as for the cylinder head).

Max warpage, please refer to the "Technical Data".
Change the engine block if it is outside the tolerances.

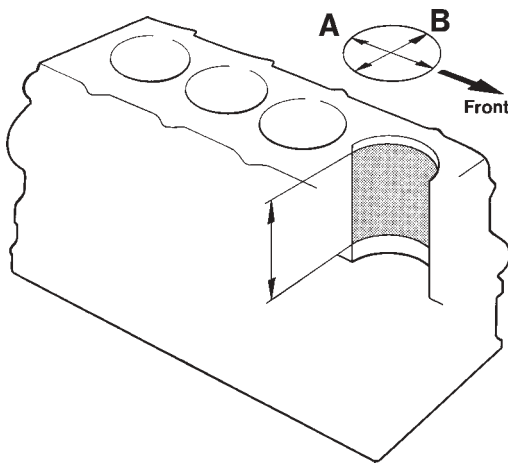

Flat Rate: 21302

Cylinder bore

Check that the cylinder bores are not scored or damaged in other ways.

Measure the cylinder bores at the upper and lower turning positions for the piston rings (app 10 mm and 100 mm below the engine block plane) and also in the middle. Measurement should be done with an internal dial gauge and both along and transverse to the engine block (A and B).

For maximum permissible cylinder diameters, please refer to "Wear tolerances" in Technical data.

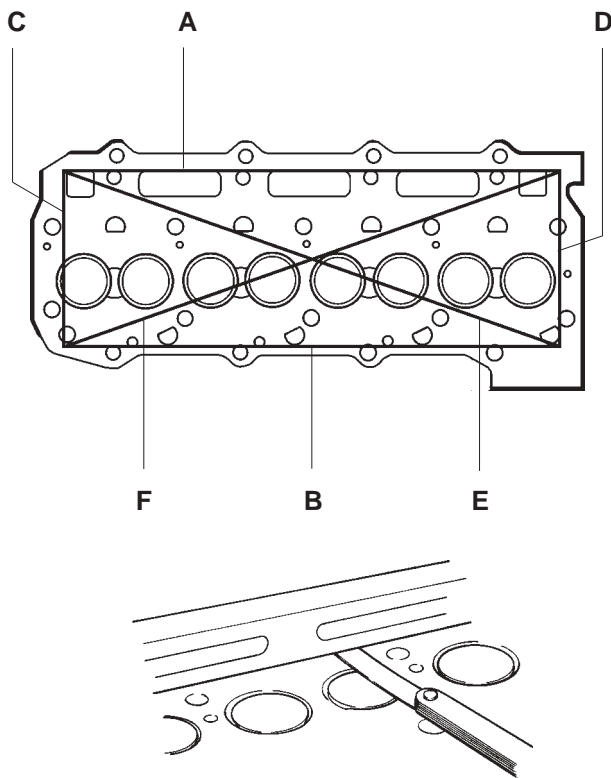

Inspecting the cylinder head

Cylinder head warpage must not exceed the value given in "Technical data". The check should be done with a feeler gauge and a straight edge. Measurement is done at six positions (A - F).

If warpage above the permissible level is found, the cylinder head must be changed. If leakage has been found, or if the cylinder head has blow lines, no special measurement is needed since such a cylinder head will have to be attended to in any case.

Check the valve seats and check that the studs are firmly seated.

Inspect the cylinder head for cracks. Carefully check the areas around the valve seats and the holes for the injector nozzles.

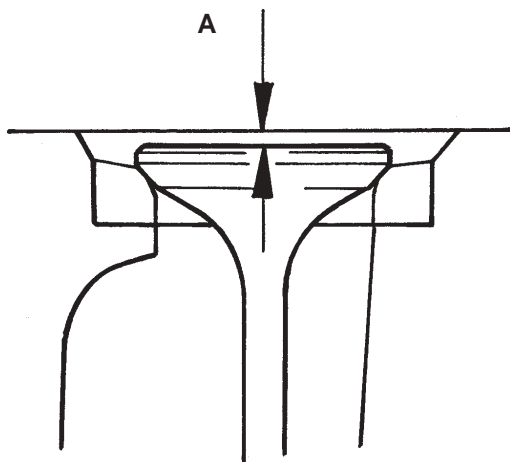

Changing the valve seats

The valve seats should be changed when distance "A", measured with a **new** valve exceeds 1.8 mm.

1. Remove the old valve seat by heating it with a gas torch (600 - 700°C), diagonally across the seat.

Let the cylinder heat cool for 3 - 5 min in the air. Then carefully tap the seat out with a mandrel (check that the cylinder head is not damaged).

The valve seat can also be milled out (check that the cylinder head is not damaged).

2. Carefully clean the valve seat bed in the cylinder head. Check the cylinder head for cracks.
3. Cool the new valve seat with carbon dioxide snow etc. to minus 60-70°C and possibly heat the cylinder head to 60-100°C.
4. Seat the seat into the cylinder head. Use a hydraulic press and a suitable mandrel.
5. Machine the seats to the correct angle and width.

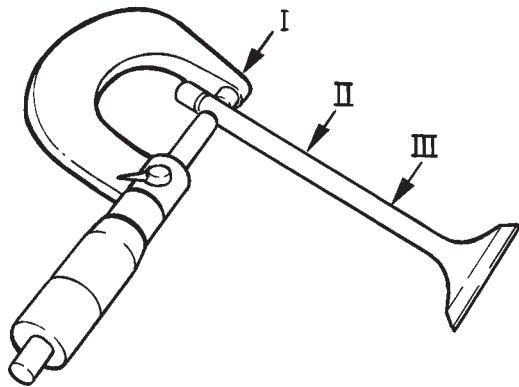
Flat Rate: 21401**Grinding of valve and valve seats**

1. Check valve stem wear. Measure the diameter with a micrometer at points I, II and III.

Diameter, min. inlet: 6.89 mm

Diameter, min. exhaust: 6.84 mm

2. Grind the valves in a valve grinding machine.
Grind the sealing surface as little as possible, but just enough to "clean" it up. If the valve disc edge (A) after grinding is less than 0.5 mm, scrap the valve. Equally, any valve with a bent valve stem must be scrapped.
3. Check valve guide wear (please refer to "Checking valveguides") before the valve seats are machined.
4. Mill the valve guides. When machined, only remove enough material to give the valve seat the correct shape and a good mating surface.

Note. Do not grind so much that the valve depth exceeds the permissible value. Please refer to "Changing the valve seats".

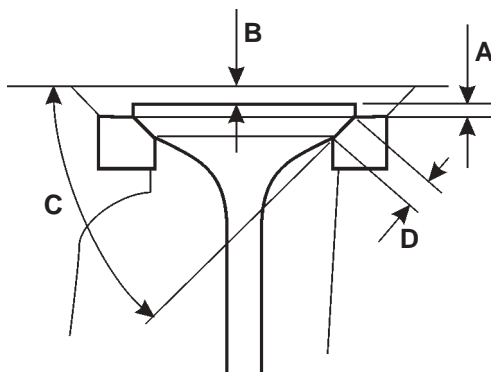

Mill new seats down so far that the distance between the cylinder head plane and the valve disc surface (C) is 0.65 - 0.95 mm for the inlet and 0.85-1.15 mm for the exhaust.

The mating face (C) must be 45 degrees and the contact surface (D) must be 1.70-2.10 mm.

5. Grind the valves in with grinding paste, and check contact with marker dye.

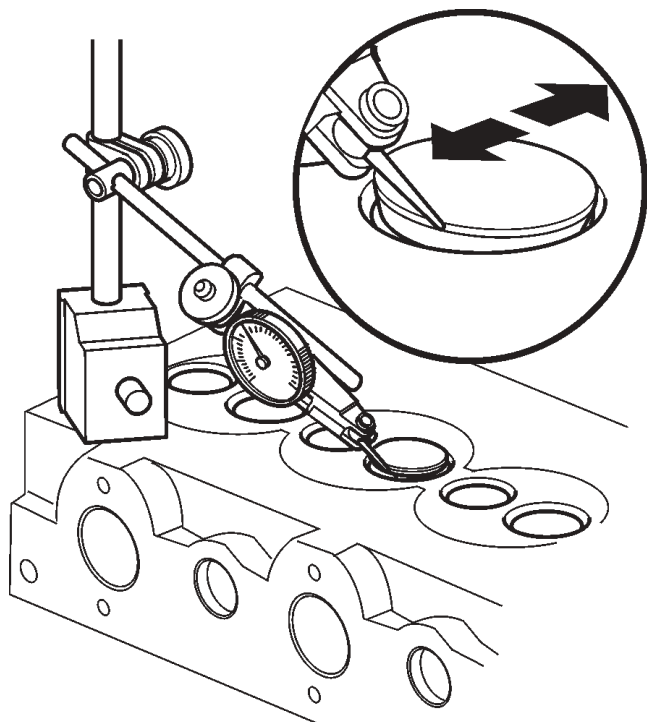

Checking the valve guides*

Special tools: 999 9683, 999 9696

- 1 Put the cylinder head on the bench, and put valves in the valve guides.
- 2 Measure the wear with a dial gauge **999 9683** and magnetic stand **999 9696**.

Lift each valve about 2 mm from its seat, put the measurement tip on the edge of the valve head and check the wear.

Permissible clearance between valve and valve guide:

Inlet valve, max clearance 0.20 mm.

Exhaust valve, max clearance 0.25 mm.

* **Note.** Since the valve guides are machined directly in the cylinder head, the cylinder head must be changed when the clearance is too great, even when the valve is new.

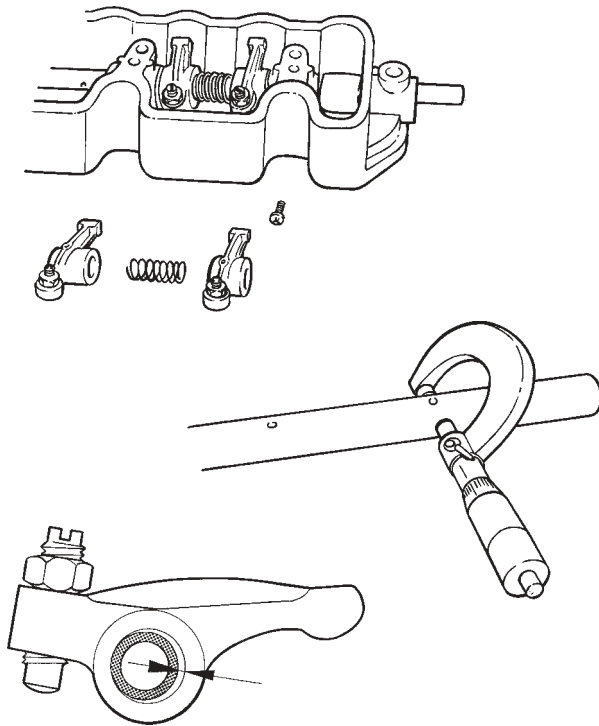
Flat Rate: 21407**Renovating the rocker arm mechanism**

1. Remove the plug at the front of the rocker arm shaft. If the shaft has a stop screw, it must be removed before the shaft is pulled out.
2. Disassemble the rocker arm mechanism. Remove the rockerarms, springs and washers.
3. Clean the components. Be specially careful with the rocker arm oil ducts and the oil holes in the rocker arms.
4. Check the wear of the rocker arm shaft with a micrometer.
5. Check whether the rocker arm bearing surfaces have been worn oval. Check the clearance between rocker arm and shaft.
Check that the spherical section of the adjustment screw is not deformed or worn. The threads on the pin and lock nut should be undamaged. The lock nut should be in good condition.
6. Oil the rocker arm shaft and disassemble the other components.

Inspecting the crankshaft

Clean all the drillings in the crankshaft carefully after disassembly and inspect it very carefully to find out whether it really needs to be renovated.

1. Check wear and ovality with a micrometer. Measure diameters "A - A" and "B - B" at points "1" and "2".

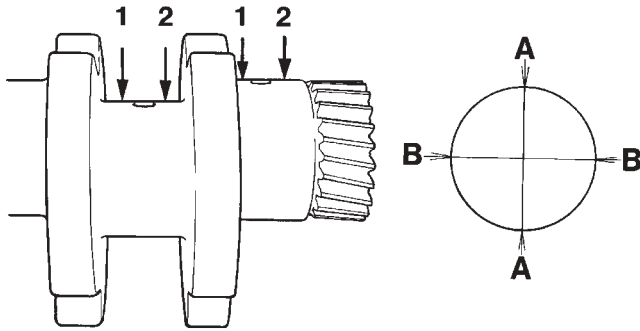

Max. permissible taper and ovality in the main and big end bearings is 0.05 mm. Change the crankshaft if these values are exceeded.

2. Measure lengthwise crookedness in the crankshaft (runout). Put the crankshaft in a couple of V-blocks which are placed under the front and rear main bearing journals. Alternately, the crankshaft can be set up between centers. Measurements shall be done on the center main bearing journal(s).

Max lengthwise crookedness (runout), please refer to "Technical Data".

If these values are exceeded, the crankshaft must be changed.

3. Check that the crankshaft seal mating surfaces on the crankshaft are not worn or damaged.

Inspection of the and crankshaft bushing and crankshaft journal

Check the bearing clearance between the crankshaft journal and the crankshaft bushing. Use both internal and external micrometers.

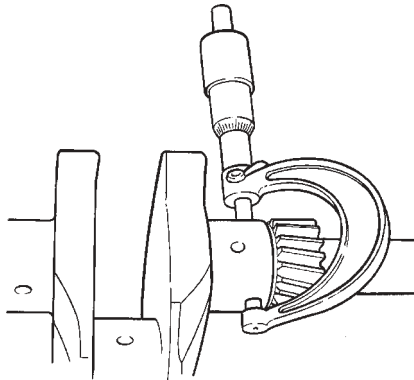

1. Measure the inner diameter of the bushing at points 1 and 2. Measure in two directions ("A" and "B") at each point.
2. Measure the outer diameter of the bearing journal and calculate the bearing clearance (difference between the former measurement and the max. diameter of the bearing journal).

Max bearing clearance, please refer to "Technical Data".

Change the bushing if the clearance exceeds the permissible value.

Inspection of main and big end bearings

Check the main and big end bearing shells, and the front main bearing bushing. Change worn bearing shells, or any with damaged bearing surfaces.

Checking the big end bearing clearance:

Special tools: 856927 (measurement putty)

The radial clearance of the big end bearings can be checked by means of measurement putty part no. 856927 as follows:

1. Wipe off any oil from the big end bearing and big end journal. Apply a piece of measurement putty, the same length as the width of the bearing journal, and put the putty along the big end bearing journal. Avoid the oil hole.
2. Install the con rod and bearing cap (note the alignment marking) and tighten the con rod screws.

Tightening torque, please refer to the "Technical Data" chapter.

NOTE! Do not rotate the con rod or crankshaft during measurement, since this spoils the measurement strip.

3. Remove the big end cap and measure the width of the pressed-out measurement putty at the widest point. Use the rule which is enclosed with the measurement putty.

Max permissible big end bearing clearance, please refer to the "Technical Data".

Change the main bearing if the bearing clearance exceeds the permissible value.

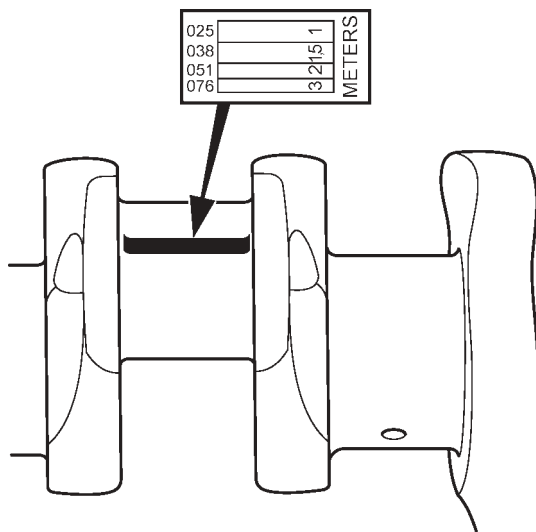
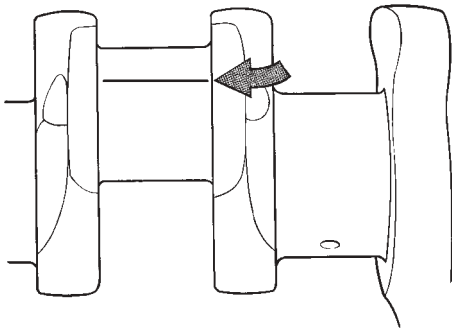

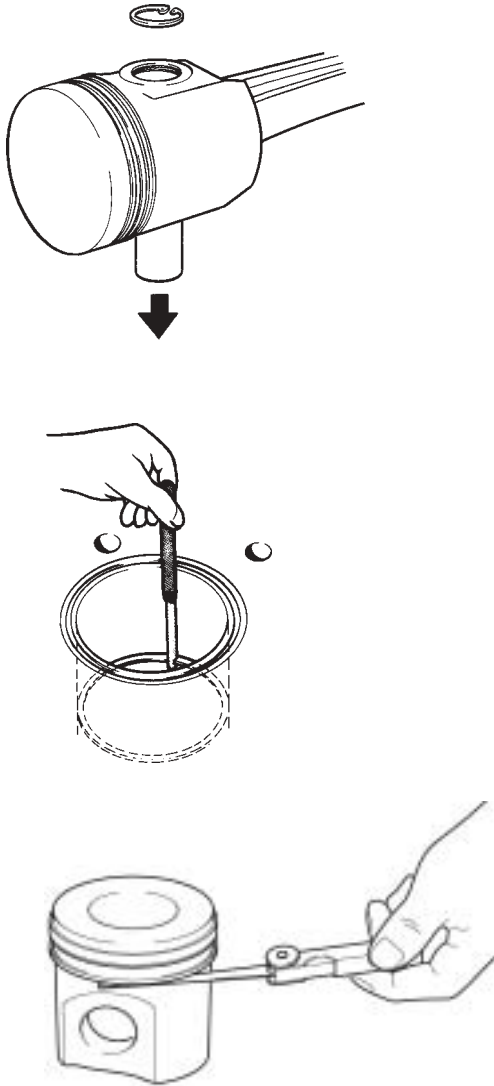

Piston ring inspection and fits

1. Remove the piston rings with piston ring pliers.
2. Remove the gudgeon pin circlips and remove the gudgeon pin carefully, with a suitable mandrel.
3. Check that the rings do not bind in the piston ring grooves.
4. Check the piston ring gap. Slide the ring down **below the bottom dead center position** using a piston. Change the piston ring if the gap exceeds 1.0 mm.

Check the piston ring gap with new rings. Please refer to the "Technical Data, specifications" chapter for measurements.

In general, piston rings should be changed if there is any noticeable wear or out - of - roundness in the cylinders, since the piston rings frequently do not end up in the same positions as they had before disassembly.

Oil consumption is also of decisive importance for the point in time when a piston ring change should be done.

5. Check the clearance in the piston ring grooves. Roll the ring in its groove in the piston, and measure the clearance at several points with a feeler gauge. Please refer to the "Technical Data, specifications" chapter for measurements.

Inspection and measurement of piston and cylinder bore

Check the pistons for cracks and worn piston ring grooves. Change the piston if it has deep grooves in the skirt surface. Likewise, if the piston has one or more cracks in the gudgeon pin hole. If any such damage is found, the injection equipment should also be checked.

Measure the piston diameter with a micrometer, at right angles to the gudgeon pin hole and 10 mm from the lower edge of the piston. Then measure the cylinder bore and calculate the clearance between cylinder and piston.

Change the piston if the clearance exceeds the maximum permissible value, or if the piston diameter is less than the minimum permissible value.

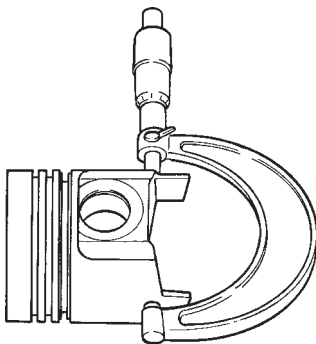

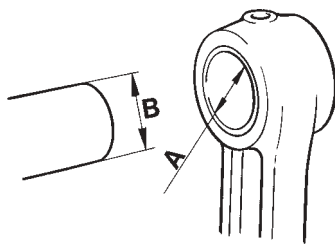
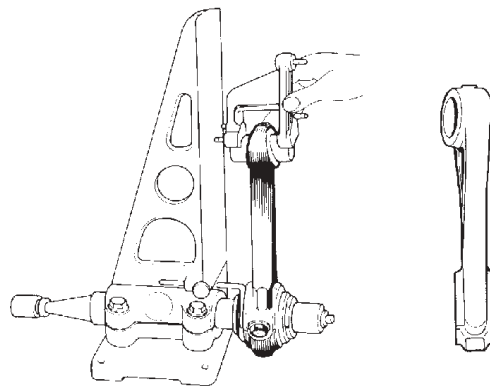
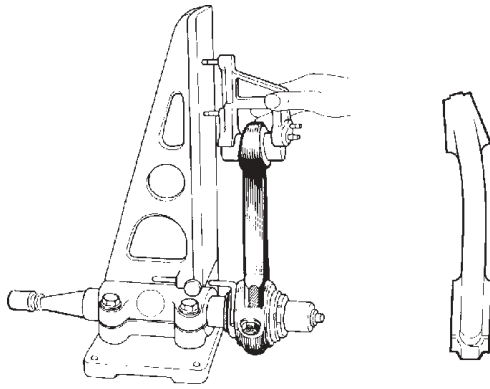

Inspecting the con rod

1. Check the con rods for cracking, straightness and twist before considering changing the gudgeon pin bush.

Discard the connecting rod if it is cracked, bent or twisted.

Check the wear in the "small end" with a gudgeon pin. When the clearance is correct, an oiled gudgeon pin should slowly slide through the bush under its own weight.

2. Use a new gudgeon pin and measure the straightness of the con rod, using a fixture. Max. deviation: 0.15 mm on 100 mm measured length
3. Measure con rod twist. Max. deviation: 0.20 mm on 100 mm measured length

4. Check the end float between the con rod and crankshaft. Change the con rod if the end float exceeds 0.035 - 0.085 mm.

Also check the gudgeon pin bushes. Please refer to "Technical Data", for the clearance between gudgeon pin (A) and gudgeon pin bush (B).

Flat Rate: 21641

Changing the gudgeon pin bushing

1. Press the old bush out.
2. Press the new bush in.

NOTE! Make sure that the oil hole in the bush lines up with the drilling in the con rod. Draw a line across the hole in the con rod and the bush, with a felt tip pen. Check that the oil duct is open after pressing.

3. Broach the bush and measure the con rod with an internal dial gauge.

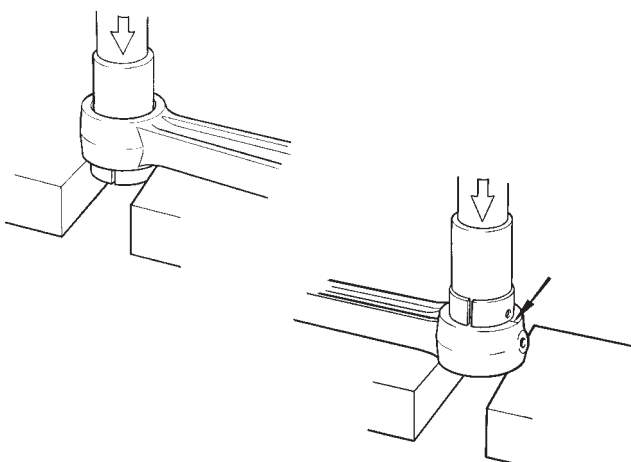

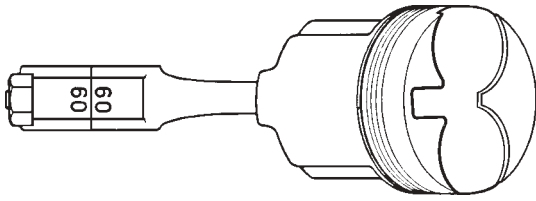

Assembling the piston, piston rings and con rod

1. Install one of the circlips in the piston.
2. Oil the gudgeon pin and gudgeon ring bush.
3. Warm the piston to about 100°C. Place the piston and con rod so that the markings line up.
The marking on the con rod and the "SHIBAURA" marking inside the piston must face the same way.

Slide the gudgeon pin in.

NOTE! It should be possible to slide the gudgeon pin in easily. It must not be driven in.

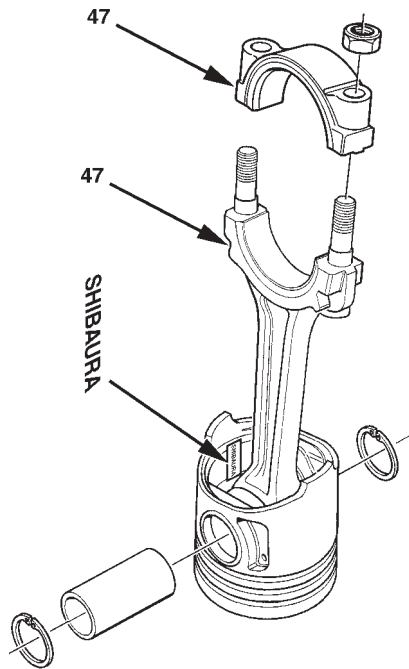

4. Install the other circlip.
5. Check that the con rod does not move stiffly in the gudgeon pin bush.
6. Check the big end bearing clearances. Please refer to "Inspecting the crankshaft" and "Inspecting the main and big end bearings".
7. Check the piston ring gap in the cylinder bores, and check that the rings do not bind in the piston ring grooves.

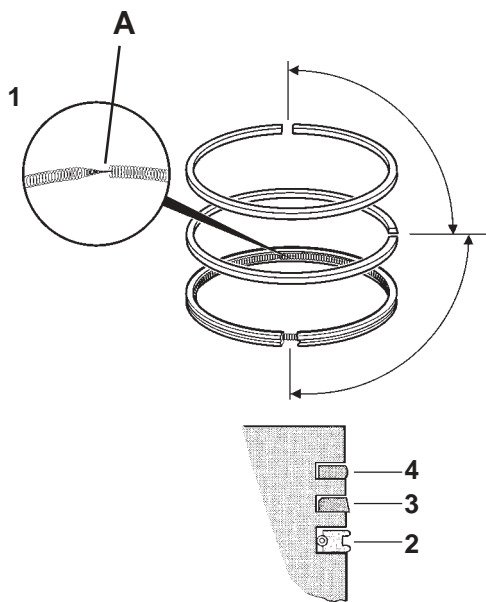

8. Install the piston rings on the pistons, using piston ring pliers. Letters or markings on ring surfaces must always be turned so that the marking faces upwards.

Install the oil scraper ring first. Put the expansion spring (1) for the oil scraper ring in the lower piston ring groove, with the location dowel (A) inside both ends of the spring. Check that the ends of the expansion spring do not overlap. Install the oil scraper ring (2) above the expansion spring. Check that the ring gap is installed with 180° displacement to the guide pin.

Install the ring with the tapered surface (3) in the centre piston ring pair so that the marking faces the piston crown.

Install the upper ring (4) with the marking upwards.

Check that the ring openings are at 90° to each other.

Camshafts and valve lifters, inspection

Check with a steel rule (1), that the valve lifter mating surfaces against the camshaft are convex or flat. If the surface is concave, change the valve lifter.

If the valve lifter is worn all across the lifting surface, the valve lifter should be scrapped. The "ditch" shows that the valve lifter has not rotated.

A dark line on the outside of the valve lifter shows that the surface is not worn, on the other hand. It is the condition of the valve lifters which determines whether it is necessary to check the camshaft wear.

Check that the lifting surfaces on the camshaft and the valve lifters do not have large areas of pitting damage. Pitting damage can occur for various reasons. The damage is caused when small pieces of metal loosen from the hardened surface. Lifters and camshafts with minor pitting damage can be used. Pitting damage seldom become worse.

Check that the camshaft bearing surfaces and cam curves are not abnormally worn. The cams could be obliquely worn in an axial direction, for example.

Change the camshaft if major damage or wear occurs.

NOTE! When the camshaft is changed, all the valve lifters must be changed.

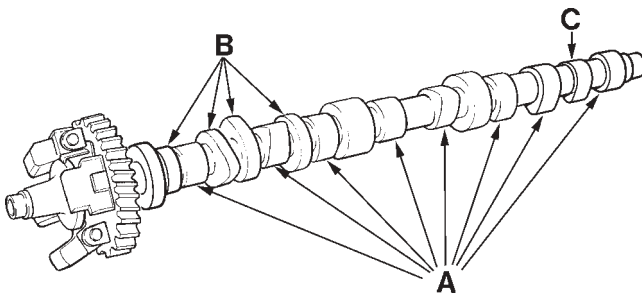
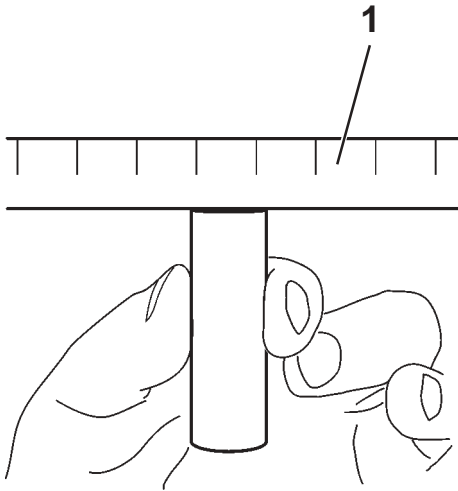

Measuring the camshaft

Cam height (inlet and exhaust), "A" 26.5 mm

Cam height "B" (for injection pump) 41.8 mm

Cam height "C" (for injection pump) 27.0 mm

Change the camshaft if the wear limits have been exceeded.

Guidelines for replacement

In normal conditions, un-evenness may occur on the camshaft lobes in the engine. This does not mean that the camshaft has to be changed. These marks do not have any negative influence on either engine performance or durability of the engine and its components.

Examples are shown below, of acceptable and not acceptable wear.

Acceptable wear.

The camshaft does not need to be changed.

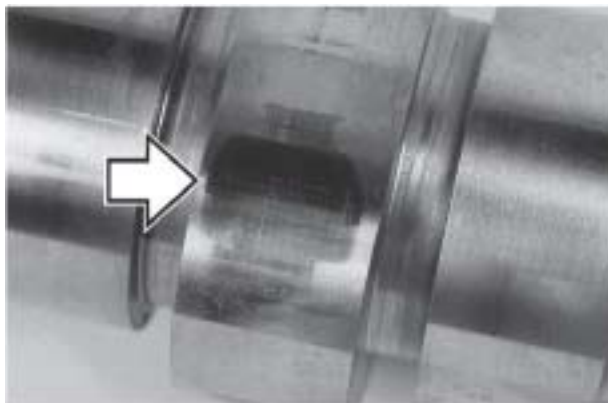
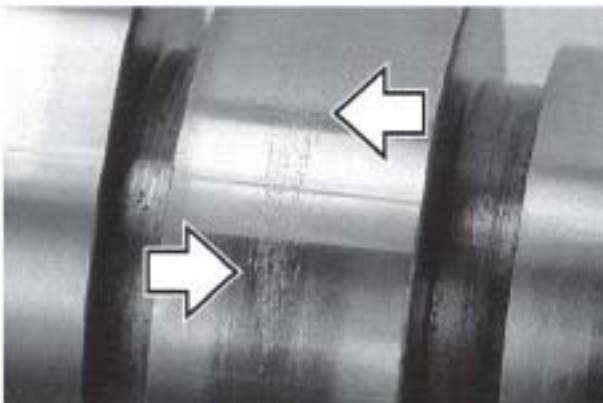

Not acceptable wear.

NOTE! The camshaft and associated rocker arms must be changed.

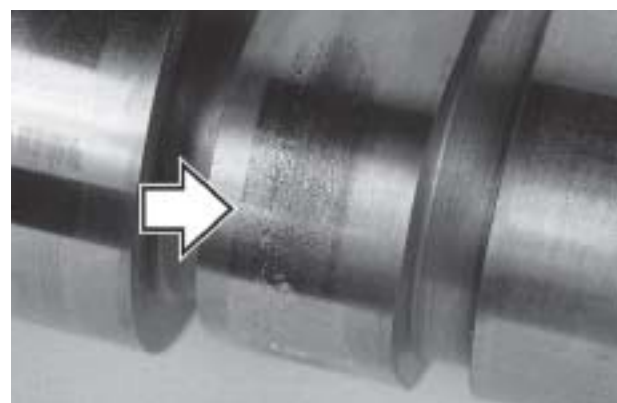
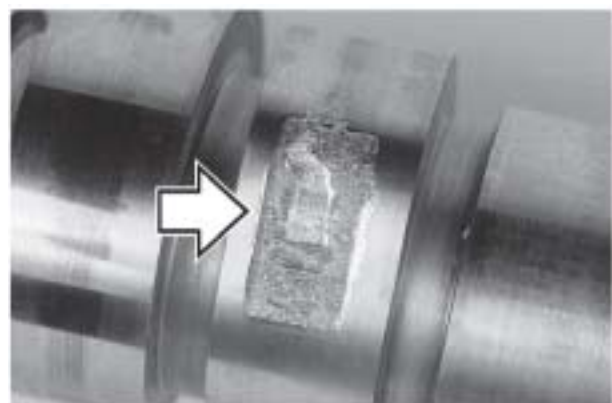

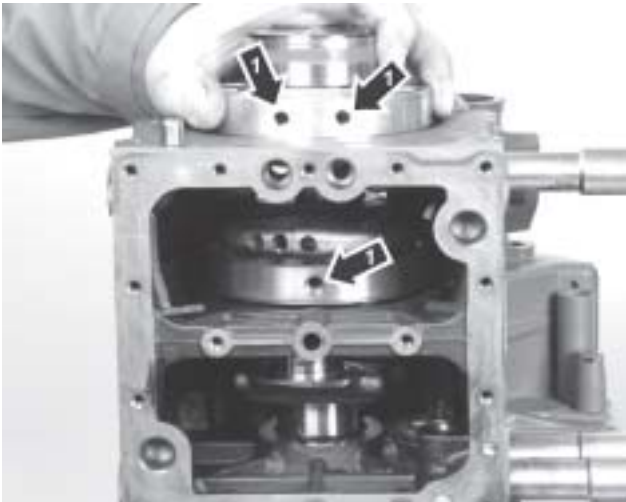
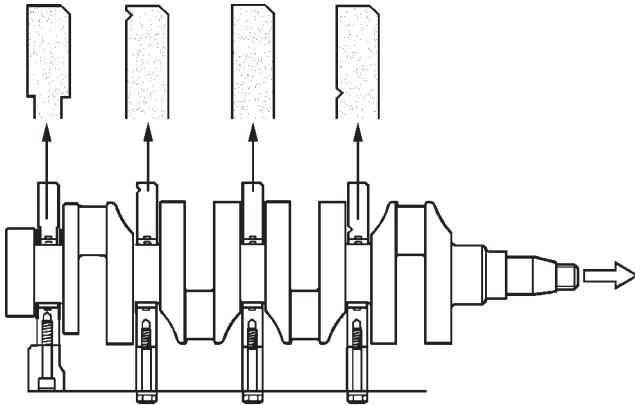

Installing the crankshaft

1. Check the cleanliness of the crankshaft drillings and bearing surfaces, engine block and bearing caps. Check that the bearing shells and their beds do not have any burrs or upsets.
2. Put the main bearings in their places in the bearing caps. Bearing shells with an oil hole must be placed in the **upper** bearing cap. **Check that the lubrication holes in the upper bearing shells are centered on the oil ducts.**
3. Oil the bearings and the main bearing journals and install the bearingcaps in their places. The chamfered edges must face forwards on all bearing caps. Please refer to the illustration, to identify the location of the bearing caps.
4. Torque the bearing caps, please refer to the "Technical Data" chapter for tightening torque.
5. Carefully lift the crankshaft into place in the engine block. Align the main bearing retainer screw holes (1) before the crankshaft is pressed into place.
Note. Tape the crankshaft gear before lifting the crankshaft into place, to prevent the gear teeth from damaging the front bearing seat.
6. Torque the main bearing caps in the engine block. Tightening torque, please refer to the "Technical Data" chapter.
7. Check that the end float does not exceed. 0.5 mm by using a special tool, magnetic stand 999 9696 and dial gauge 998 9876.

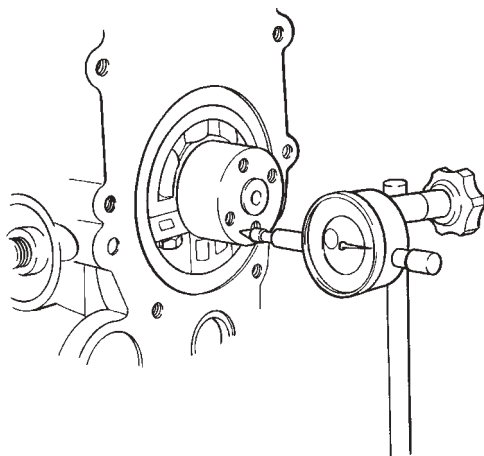

Installing the piston in the cylinder and the oil pan

Note. After changing the crankshaft, piston or gudgeon pin, the weight difference between the con rod complete with piston and piston rings must not exceed 10 g between each cylinder. Also refer to "Pistons, installing" and "Assembly of pistons, piston rings and con rod".

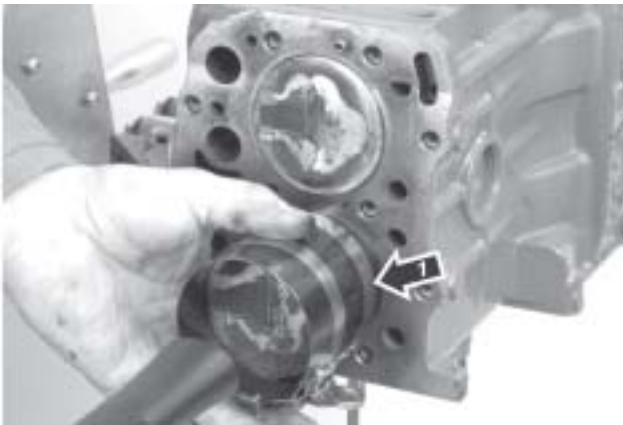
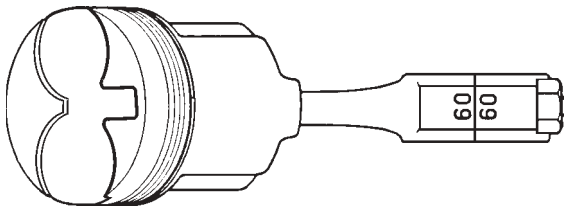

1. Lubricate the pistons and piston rings with engine oil beside the rings, so that the oil finds its way into the piston ring grooves. Turn the piston rings so that the piston ring gaps are aligned at a 90° angle to each other.

Make sure that no piston ring gap is placed centrally against the gudgeon pin.

2. Put the bearing shells in their places in the con rods and caps. Oil the crankshaft journal with engine oil.
3. Check that the markings on the piston crown or inside the piston line up with those on the con rod. Use a piston ring compressor (1) and install the piston with con rod in its cylinder, starting with cylinder no. 1 (forwards).

⚠ IMPORTANT! Make sure that the con rod studs do not strike the crankshaft when driven down.

The con rod with the **lowest number** must be installed furthest forward (in cylinder no. 1) and accordingly, the con rod with the highest number goes closest to the flywheel.

The con rod must be aligned with the marking (number/paint dot) facing the injection pump (camshaft side).

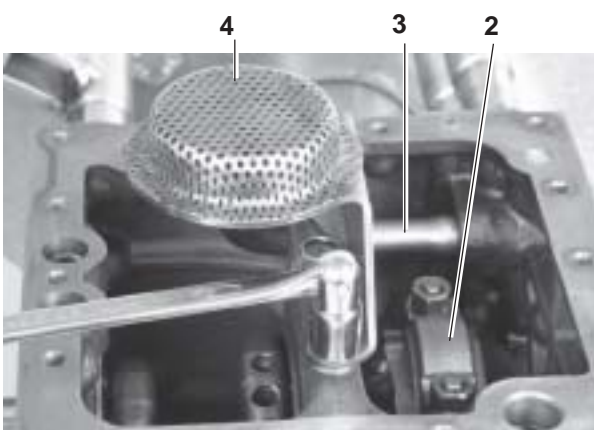

4. Install the bearing caps (2) and tighten the con rod screws. Tightening torque, please refer to the "Technical Data" chapter. Bearing caps must be installed so that the number markings/paint marks on con rod and cap coincide. Undamaged con rod screws do not need to be changed, they can be put back again.
5. Install the oil suction pipe (3) and oil strainer (4). Tightening torque, please refer to the "Technical Data" chapter. Use a new O - ring.

⚠ IMPORTANT! Do not press the oil suction pipe down to the bottom of the hole. There is a risk that an oil duct could be blocked.

6. Install the sump together with a new gasket. Tightening torque, please refer to the "Technical Data" chapter.

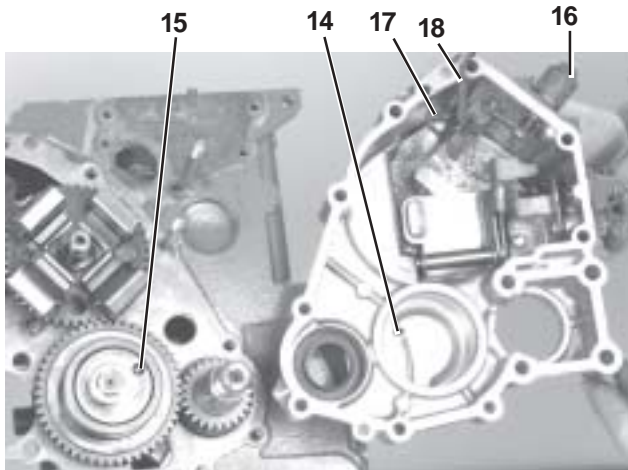
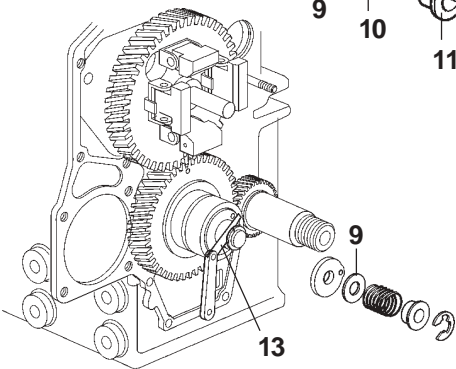
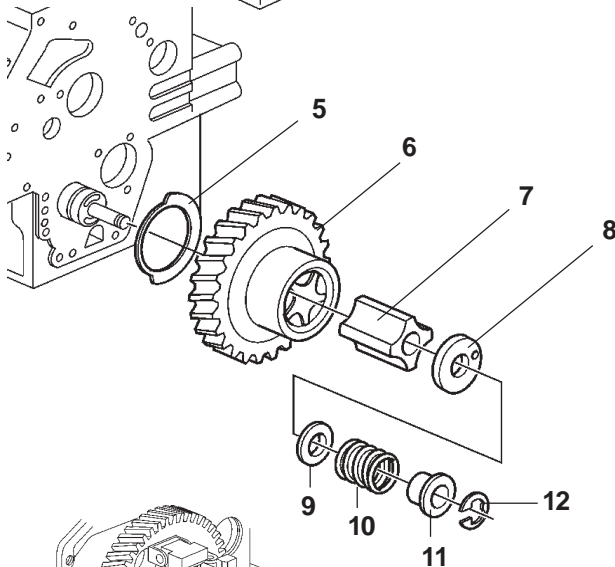
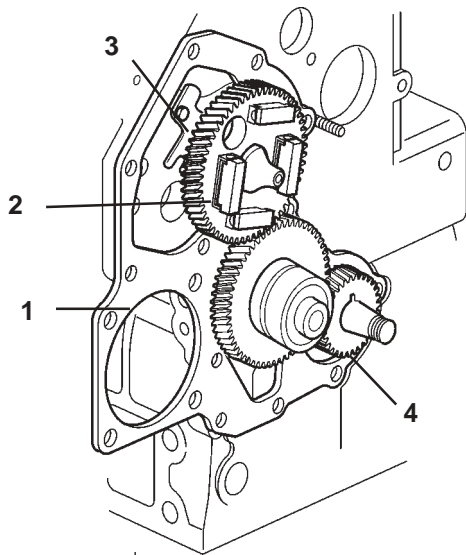

Installing the timing gear and injection pump

Also refer to "Timing gear, installation".

1. Install the timing gear plate (1) with new gasket.
2. Oil the camshaft bearing surfaces and carefully lift the camshaft (2) into place, complete with drive gear and regulator weights.

Note. Be careful to avoid damaging the bearings, bearing tracks and camshaft lobes.

3. Install lock plate (3) for the camshaft in the correct position and torque it.
4. Put the key in place in the crankshaft and install the crankshaft pulley (4).

⚠ IMPORTANT! The components must be oiled before installation.

⚠ IMPORTANT! Make sure that the gear wheel markings coincide.

5. Install the thrust washer (5) on the idler wheel shaft stub. Install the idler wheel (6) in accordance with the markings.

NOTE! Do not turn the crankshaft before the timing gear cover has been installed.

6. Install the inner rotor (7) and the oil pump cover (8). Install shims (9), spring (10), spring washer (11) and lock washer (12).
7. Adjust the oil pump end float (13) to 0.10 - 0.15 mm. Shims (9) are available in thicknesses of 0.10; 0.15; 0.20 and 0.50 mm.
8. Install a new, possibly adjusted gasket for the timing gear cover. Center the cover in front of the oil pump.

Note. Check that the tubular pin (14) in the timing cover can engage in the hole (15) in the oil pump cover. Turn the cover back and forwards, and center it in the mid position. The stop arm (16) must be turned and held in place when the timing cover is installed.

9. Check that the starter spring (17) is correctly located in the timing cover, and is connected to the regulator arm (18).

Put the timing gear cover in place. Insert the regulator arm through the hole in the engine block. Screw the timing gear cover down.

7. Turn the stop arm (19) clockwise and connect the arm (20) to the injection pump. Install the clip (21).

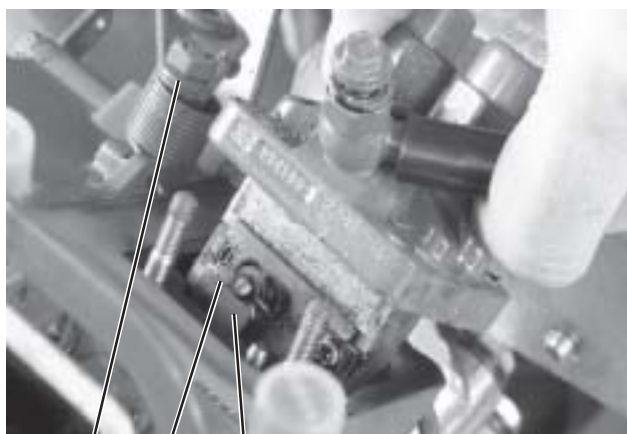

19 21 20

NOTE! Be careful to ensure that the shim/gasket which was placed underneath the injection pump flange is put back, before the pump is placed in the block (applies when the pump has been removed).

8. Torque the injection pump, please refer to the "Technical Data" chapter for tightening torque.
9. Install a new front crankshaft seal, please refer to "Front crankshaft seal, changing". Put the key in place in the crankshaft and install the crankshaft pulley. Tightening torque, please refer to the "Technical Data" chapter.



Flank clearance, checking

Use a feeler gauge to measure the flank clearance (1) between the oil pump gear and the camshaft gear.

Use a feeler gauge to measure the flank clearance (2) between the oil pump gear and the crankshaft gear.

Please refer to the "Technical Data" chapter for min and max values.

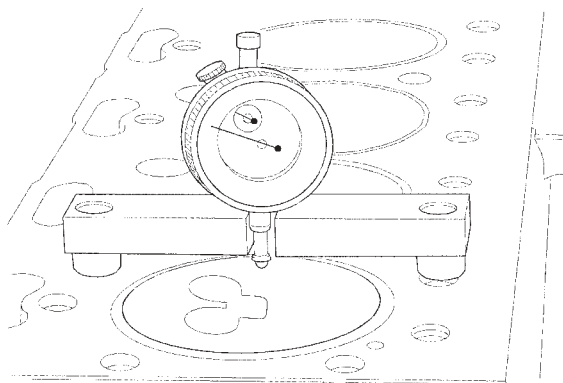
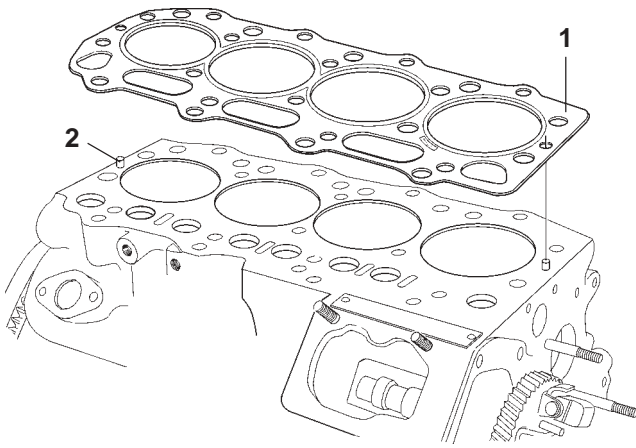

Difference in height between pistons and engine block plane

0.55 to 0.64 mm
0.65 to 0.75 mm

Gasket thickness

1.2 mm
1.3 mm

Measuring the piston height, installing the cylinder head and other assembly

Also refer to “Cylinder head, installation”.

1. Clean the cylinder head and engine block mating planes. Remove any rust from screw holes and from the threads on the cylinder head screws.
2. Put the valve lifters in their original places.

⚠ IMPORTANT! Please refer to “Timing gear, assembly”, for the positions of the valve lifters.

3. Put the new cylinder head gasket in place with the marking (1) upwards. Check that the tubular pins (2) are installed in the block.

NOTE! The new gasket must be of the same thickness as the old one.

NOTE! If a piston, con rod, crankshaft or engine block has been changed, new measurement must be done.

4. Dip the cylinder head screws in engine oil and leave them to run off on a strainer. The screws should have stopped dripping when they are installed (otherwise oil cold well up and be regarded as leakage).

⚠ IMPORTANT! The screws are phosphated and must not be cleaned with a steel wire brush. If the cylinder head is painted, the contact surfaces for the cylinder head screws must be free from paint. The clamping force in the joint could otherwise be very poor.

5. Put the cylinder head in place.
6. Torque the cylinder head screws (3) in three stages, where the last stage is to the stated torque. Tightening schedule and torque, please refer to “Technical Data”.

Re-tighten all screws.

7. Install the glowplugs (4) and busbar (5).

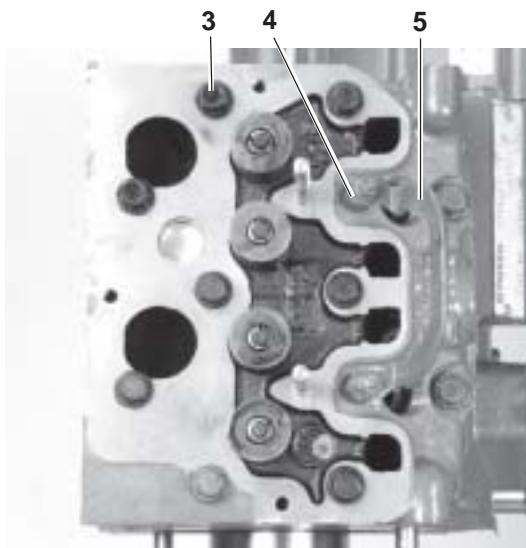



7 9 8 6

8. Install the push rods (6), valve caps (7) and rocker arm mechanism (8) with gasket. Torque the nuts (9), please refer to "Technical Data".

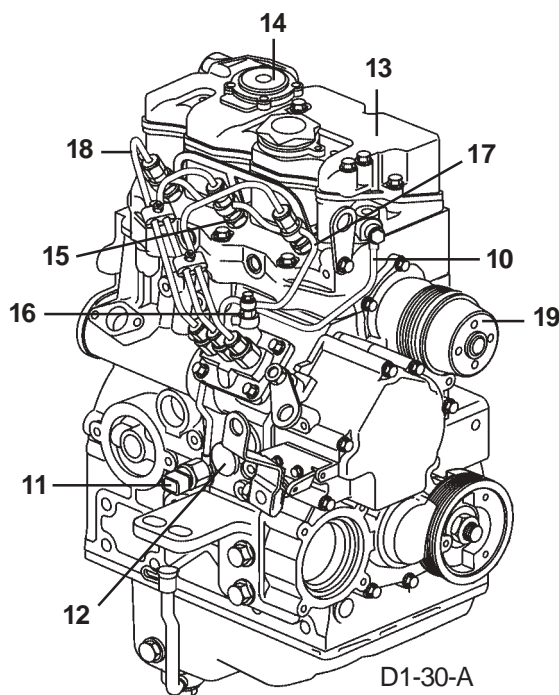

D1-30-A

9. Install the oil supply pipe (10) between the block and the rocker arm mechanism, together with the oil pressure monitor (11). Install the oil pressure reduction valve (12). Tightening torque, please refer to "Technical Data".

Turn the crankshaft round a couple of rotations.

10. Adjust the valve clearance, please refer to "Valves, adjustment".
11. Install the valve cover (13). Check that the small ventilation hole in the crankcase ventilation cover (14) is open.
12. Install copper gaskets for the injectors.
Install the injectors (15). Torque please refer to "Technical Data".
13. Install the hollow screw (16) on the injection pump and the banjo nipple with new copper washers.
14. Install new copper gaskets and install the return fuel pipe (17). Tighten the nuts and connect the return pipe.
15. Install the fuel supply pipes (18), tightening torque, please refer to "Technical Data".
16. Install the coolant pump (19) with spacer (D1-13-A) and a new gasket.

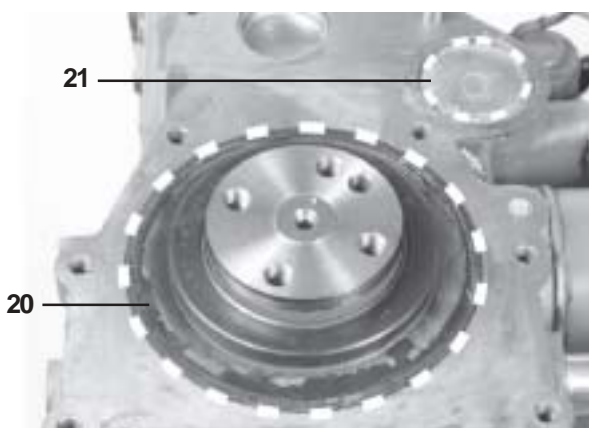

17. Install the rear crankshaft seal seat in the engine block and the mating surface on the inner flywheel housing. Install the rear crankshaft seal (20).
18. Apply an even layer of sealant (VP no. 840 879) around the crankshaft seal and the camshaft cover (21).

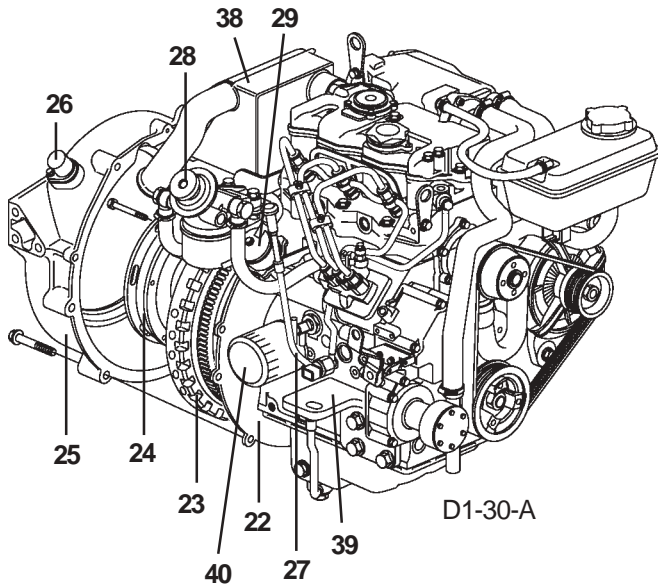

19. Install the inner flywheel housing (22). Install the flywheel (23) as previously marked, please refer to "Technical Data" for tightening torque. Then install the flexible coupling (24) and the flywheel housing (25). Install the engine speed sensor (26) on the flywheel housing.
 20. Install the dipstick (27).
 20. Install the fuel filter bracket (28) with anchorage and feed pump (29). Please refer to "Technical Data" for tightening torque.
- Connect the fuel hoses and tighten the hose clamps.

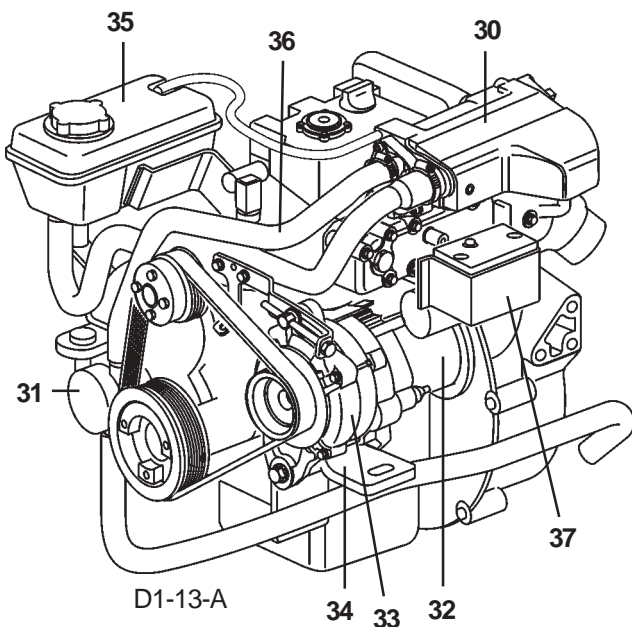

21. Install the heat exchanger/exhaust manifold (30) and sea water pump (31).
22. Install the starter motor (32) and alternator (33), together with the front engine mounting (34).
23. Install the expansion tank with fixing yoke (35).
24. Connect all coolant hoses (36). Tighten all hose clamps and brackets.
25. Install the electronic box (37) with cable harness, connect the connectors and other electrical connections. Clamp the cable harness as previously noted.
26. Install the induction silencer (38).
27. Remove the engine fixture and install the engine mounting (39).
28. Install a new oil filter (40). Add oil and coolant, as specified in "Technical Data".
29. Install the engine in the boat. Connect the remaining connections and controls to the engine. Open the fuel taps and the sea cock. Start the engine and check carefully that no leakage occurs.

Cylinder head, removal

Coolant drained. Air filter housing, heat exchanger and coolant pump with spacer (D1-13) removed.

1

Remove the screw (1) which holds the fuel filter bracket to the cylinder head.

Unscrew the valve cover.

Undo the cable (2) for the glow plugs.



2

Undo and remove the injector pipes (1). Undo and remove the return fuel pipe (2).

⚠ IMPORTANT! Seal all openings in the fuel system with protective caps.



3

Undo the oil supply pipe (1) by the cylinder head.

Unscrew the injectors (2).

⚠ IMPORTANT! Seal all openings on the injectors with protective caps.

Unscrew the nuts (3) which hold the rocker arm bridge. The D1-20, D1-30 and D2-40 engines also have screws which must be undone. Carefully prise the rocker arm bridge loose.

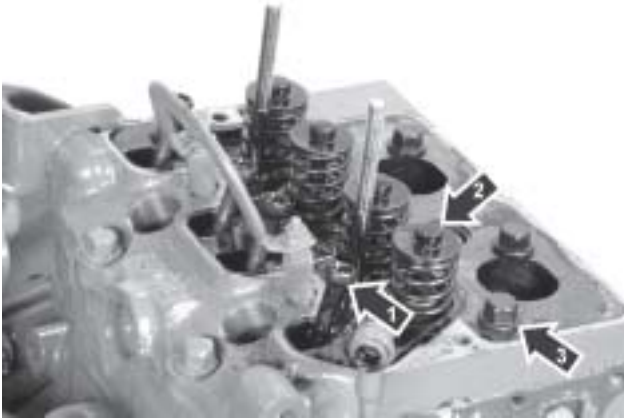

**4**

Remove the push rods (1) and valve caps (2). Mark them.

Undo the cylinder head screws (3) in the opposite sequence to when they are tightened, please refer to "Technical Data". Remove the cylinder head and gasket.

Valves, removing

Cylinder head removed.

Special tools: 885023, 885498

1

Remove the busbar (1) and glow plugs (2).

Remove the valves (3) with a valve compressor, tool nos. 885023 and 885498. Mark the valves.

Remove the valve seals.



Valves, installation

Special tools: 885023, 885498

1

Install the valve (1) in the cylinder head as marked. Install a new valve seal (2), spring (3) and valve spring washer (4).

Put the valve compressor in place. Compress the valve spring and install the collets (5).

2

Install the glow plugs and tighten to the specified torque, please refer to the "Technical Data" chapter. Install the bus bar.

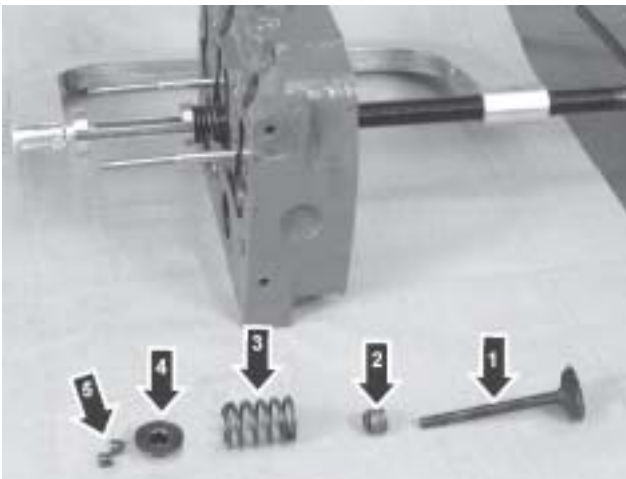

Cylinder head, installation

Special tools: 998 9876, 999 5192

1

Check the piston height with tools 9989876 and 9995192. Select a new cylinder head gasket, please refer to "Technical data".

Check that the valve lifters are in place.

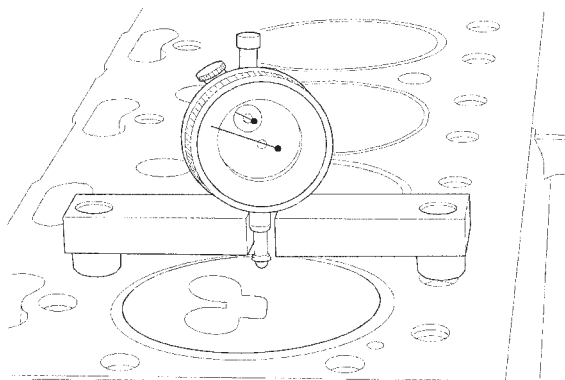

2

Check that the engine block guide pins for the cylinder head are in place. Install a new cylinder head gasket with the marking upwards.

Put the cylinder head in place. Insert the screws (1) and torque them as in the tightening schedule, to the torque specified in "Technical Data".

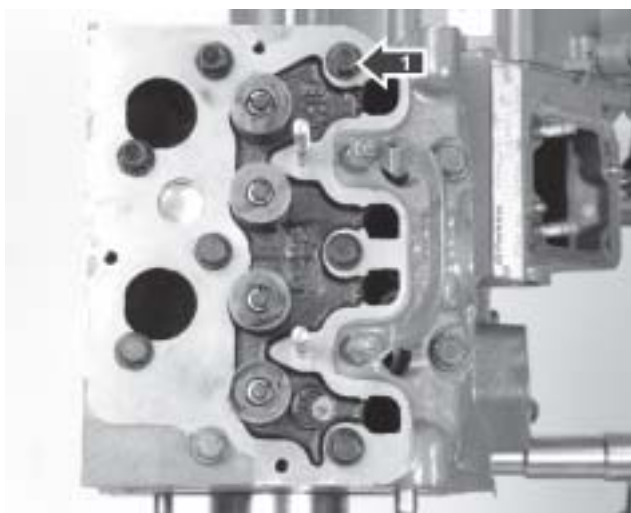

3

Install the push rods (1) and valve caps (2).



**4**

Install a new seal on the rocker arm bridge (1). Install a new rocker arm bridge. Make sure that the push rods and rocker arms (2) are correctly aligned.

Tighten the nuts (3) evenly to the specified torque, please refer to the "Technical Data" chapter.

**5**

Install the oil supply pipe (1) on the cylinder head with new seals.

**6**

Installing the injectors:

Apply sealant part. no. 840879 to the threads of the two lowest screws (1).

Put new copper seals on the bottom of the cylinder head.

Install the injectors and tighten them evenly to the specified torque, please refer to the "Technical Data" chapter.

Timing gear, removing

Cylinder head removed

Special tools: 885820, 885 822



1

Unscrew the seawater pump (1). Remove the end panel (2) and the screws (3).



2

Unscrew the centre nut from the pulley. Install tool no. 885820 on the pulley and remove it.

Remove the Woodruff key from the groove in the shaft



3

Unscrew the injection pump (1). Lift it up until the lock clip (2) is accessible. Undo the clip and release the control rod (3).



4

Unscrew the timing gear cover screws (1) and nut (2).
Remove the cover.



5

Undo the fuel pipe from the fuel filter (1).
Unscrew the fuel feed pump (2). Wipe up the fuel that
has run out.



6

Remove the valve lifters with magnetic tool 885822.

⚠ IMPORTANT! Mark the valve lifters so that they
are put back in the same positions. The D1-20
and D2-40 engines have some valve lifters
which are chamfered off.



7

Rotate the camshaft until the socket cap screw (1) becomes visible in the hole in the camshaft drive gear. Unscrew the socket cap screw and hex head screw (2). Remove the lock plate (3).

Remove the camshaft regulator sleeve (4).

Pull the camshaft out carefully.

⚠ IMPORTANT! There is a risk that the inner camshaft bearing can be damaged by a camshaft lobe if it is pulled out with force.



8

Remove the circlip (1) on the oil pump shaft. Remove all components of the oil pump. Note the spacer washer (2) inside the oil pump gear.



9

Unscrew the remaining screws (1). Remove the timing gear plate (2).

Undo the crankshaft gear (3) with a puller. Remove the gear wheel and its Woodruff key.

Timing gear, installation

1

Put the gear wheel (1) and its key on the crankshaft.
Tap the gear wheel on.

Install a new gasket and timing gear plate (2).

Tighten the inner screws (3) on the timing gear plate.



2

Carefully insert the camshaft.

⚠ IMPORTANT! If you force the camshaft in, there is a risk that one of the cam lobes will damage an internal bearing.

Put the lock plate (1) in position. Rotate the camshaft until the screw hole for the socket cap screw (2) becomes visible in the hole in the camshaft drive gear. Screw the lock plate down.

Install the camshaft regulator sleeve (3).



3

Fit the thrust washing (1) in place.

Put the oil pump gear wheel (2) in place. Make sure that the markings (3) on the gear wheel line up with the markings (4) on the other gear wheels.

Check the gear flank clearance, please refer to "Gear flank clearance, checking".

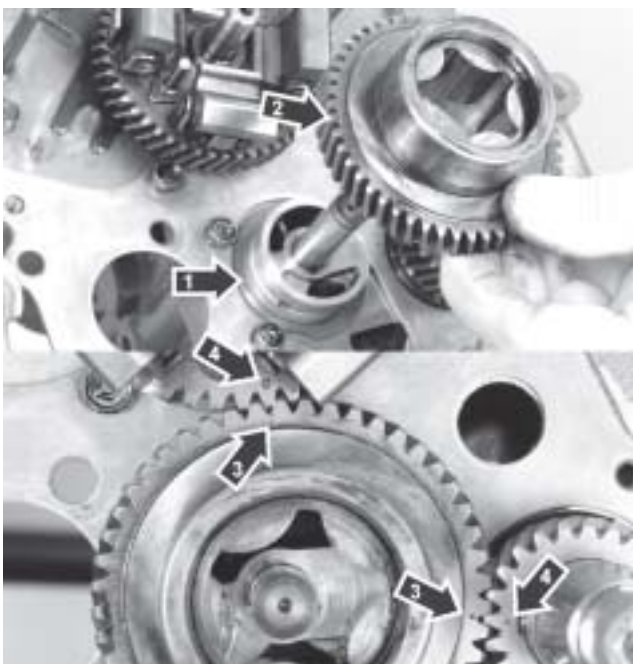

**4**

Install the pump gear (1), end washer (2), shims (3), spring (4) and bush (5) in the oil pump gear. Put the circlip (6) on the shaft.

NOTE! Note that the end washer (2) has a hole (7) which must mate up with the guide pin in the timing gear cover.

Install a new gasket on the timing cover.

NOTE! If the gasket has a center section (8), this must be cut away.

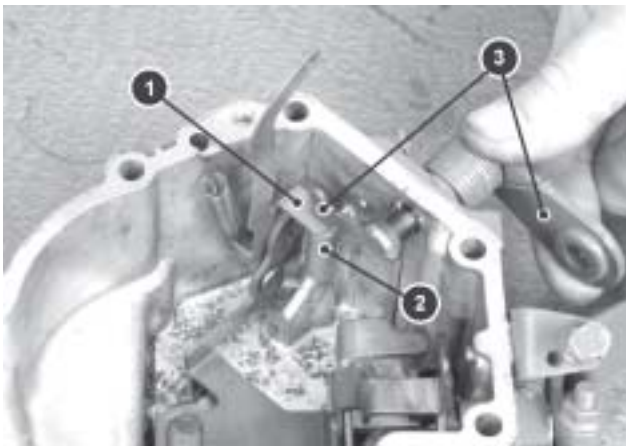
**5**

Put the control rod (1) on the heel (2) in the timing gear cover. Turn the stop arm (3) round so that the control rod is held against the heel.

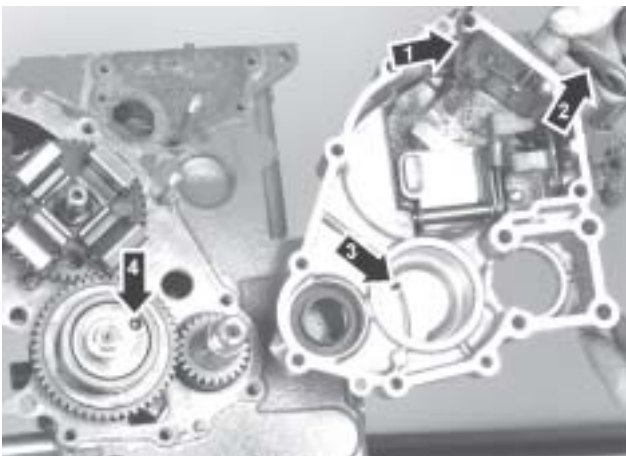
**6**

Install the timing gear cover at the same time as the control rod (1) is held fixed by the stop arm (2).

Put the timing gear cover in place. Make sure that the control rod ends up in the correct position and that the pin (3) engages in the hole (4) in the oil pump end washer.

Screw the timing gear cover down.



7

Put a new O-ring (1) in the groove in the seawater pump.

Install the rear end piece (2) with a new gasket and its four screws (3).

NOTE! The longest screws must be put on the outside (D1-13, D1-20).

Install the seawater pump and screw it in place.

8

Install the pulley key on the crankshaft.

Install the pulley and tighten it to the specified torque with the center nut, please refer to the "Technical Data" chapter.



9

Put the valve lifters in place as marked.

⚠ IMPORTANT! All valve lifters must be put back in their old places. Not that on engine D1-20, valve lifter no. 2 for cylinder 1 has one chamfer (1). On engine D2-40, both valve lifters for cylinder 1 have one chamfer.

D1-20 A

Pistons, removal

Engine oil drained. Cylinder head removed.

1

Turn the engine upside down. Undo the oil drain pipe anchorage (1) on the cylinder head.

Unscrew the sump (2) and remove it together with the oil drain pipe (3).



2

Unscrew the oil suction strainer (1). Remove the suction pipe (2) with its O-ring.

Unscrew the bearing caps (3) for the con rods.

⚠ IMPORTANT! Note the markings on the bearing caps and their locations.

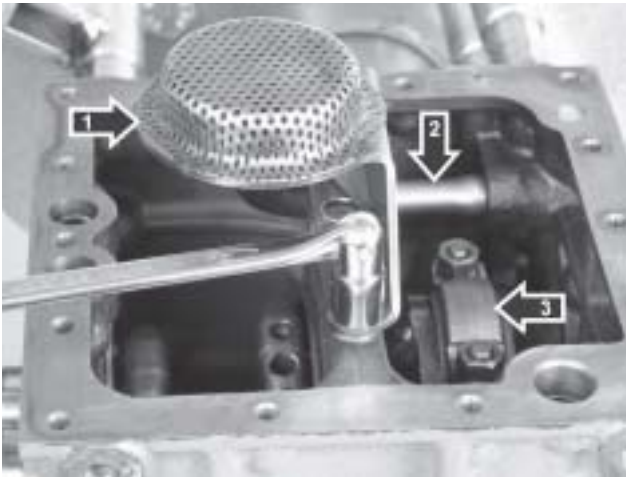

3

Press the pistons out.

NOTE! There might be a soot deposit on the top of the cylinder bores. Remove the deposit to make it easier to press the pistons out.

Big end bearing, change

Pistons, removed



1

Remove the big end bearings (1) and put the new ones in position.

Flat Rate: 21320

Pistons, change



1

Note the positions of the pistons in relation to the crankshaft.

Remove the circlips (1) and press the gudgeon pin out (2).

2

Clean the gudgeon pin bushing and check it.

3

Install a new piston in the correct position.

Press the gudgeon pin in.

Install the circlips with the lugs facing upwards.

Pistons, installation

1

Also refer to “Assembly of pistons, piston rings and con rod”.

Install a piston ring compressor on the piston.

Lubricate the con rod bearing shells and studs with engine oil.



2

Turn the crankshaft round so that the big end bearing is in the lowest position for the piston to be installed.

Install the piston (1) in the bore and carefully tap it down. The piston marking “SHIBAURA” must face the injection pump side.

⚠ IMPORTANT! Make sure that the con rod studs to not strike the crankshaft when driven down.

3

Install the big end bearing cap as marked. Torque to 23 Nm (D1-13, D1-20 or 32 Nm (D1-30, D2-40).

Check the movement of the big end bearing.

Repeat the procedure to install the remaining pistons.

Crankshaft, remove

Removed pistons, flywheel and timing gear



1

Unscrew the inner timing gear plate (1).



2

Remove the rear crankshaft seal (1) from the crankshaft.

3

Unscrew the oil pressure reduction valve.

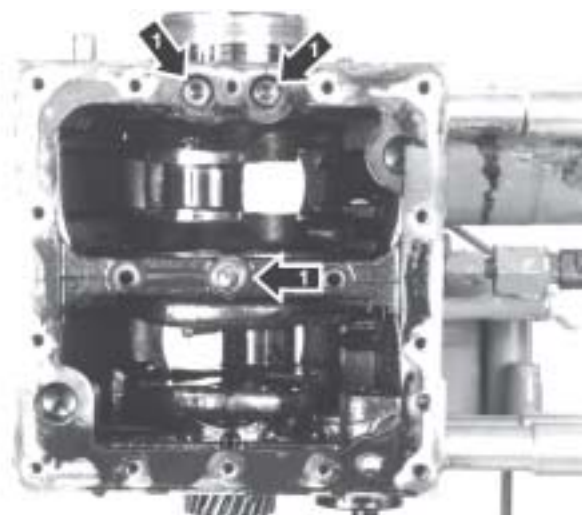

4

Undo the screws (1) which hold the main bearing caps. Lift the crankshaft out.

NOTE! Tape the crankshaft gear teeth to protect the bearing when the shaft is pulled out.



D1-20, D1-30

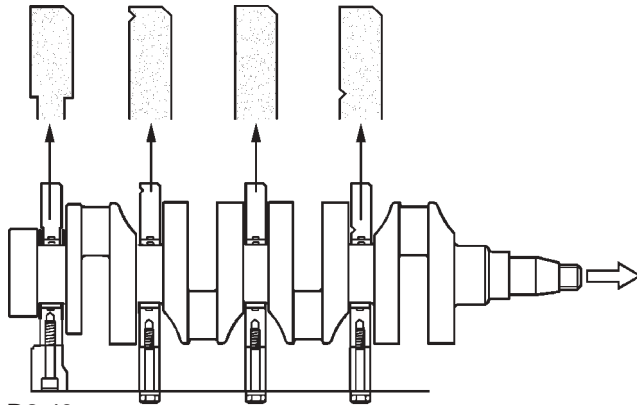

D2-40

Main bearings, change

Crankshaft, removed

1

Unscrew the main bearing retainers (1) and pull them off the crankshaft.



IMPORTANT! The marking (2) on all main bearing retainers for D1-20, D1-30 and D2-40 must be carefully noted to prevent incorrect positioning during assembly. Also note the oil holes (3) in the bearing caps.



2

Drive out the main bearing bush (1) located in the engine block. Use a suitable mandrel and tap the bushing out from inside the crankcase.



3

Inspect all main bearings (1). Remove them from their holders.

Check and measure the bearing surfaces (2) on the crankshaft, please refer to "crankshaft inspection".



4

Install the new main bearings and lubricate them with engine oil.

Install the main bearing retainers (1) on the crankshaft in accordance with the markings (2). Torque the screws to 23 Nm.

⚠ IMPORTANT! Put the main bearing retainers back in their original places. The oil holes (3) must face the corresponding holes in the engine block.

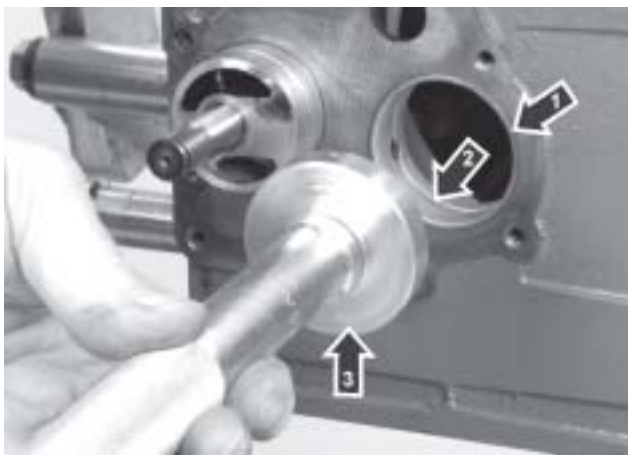

5

Install the main bearing bush (1) in the engine block.

⚠ IMPORTANT! Position the bushing so that its oil hole is correctly aligned in the engine block. The oil groove (2) in the bushing must be furthest in.

Tap the bushing in with a suitable mandrel (3) until it lines up with the engine block.

Check that the oil duct is open after pressing in. Also check the internal diameter of the bushing. For dimensions, please refer to "Technical Data".

Crankshaft, assembly

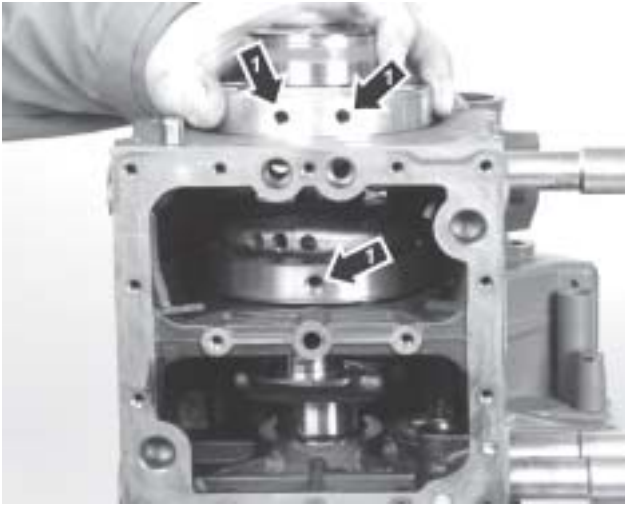

1

Lift the crankshaft into place.

Align the main bearing retainer screw holes (1) before the crankshaft is pressed into place.

2

Carefully tap the crankshaft into place if necessary, and torque the main bearing retainers to 27 Nm.

Check that the crankshaft can be turned easily.

3

Install the oil pressure reduction valve with a new seal. Torque to 64 Nm.

Install a rear crankshaft seal, please refer to "Rear crankshaft seal, changing".

Flat Rate: 21661

Flywheel, change

**1**

Remove the engine speed sensor (1) and filter housing bracket (2).

Remove the flywheel cover (3) and flexible coupling.

**2**

Unscrew the flywheel (1) and remove it.

Clean and check the crankshaft seal.

3

Carefully clean the crankshaft and flywheel.

Install the new flywheel and tighten it to the specified torque, please refer to the "Technical Data" chapter.

Install the flexible coupling, flywheel housing, filter housing bracket and engine speed sensor.

Crankcase seal rear, change

Flywheel removed



1

Unscrew the inner timing gear plate (1).



2

Remove the rear crankshaft seal (1).

Check that the area for the crankshaft seal on the engine block, the crankshaft and the inner flywheel housing are cleaned.

Lubricate the lip of the seal on the new crankshaft seal with engine oil and put the seal in place.

Apply sealant part no. 840879 all round the crankshaft seal (2) and the camshaft cover (3).

Fix the inner flywheel plate.

Flat Rate: 21672**Crankshaft seal, front, change**

Special tools: 885820, 9995919



1

Undo the drive belt.

Unscrew the centre nut from the crankshaft pulley. Install tool no. 885820 on the pulley and remove it.

Remove the Woodruff key from the groove in the shaft



2

Insert tool no. 9995919 under the lip of the crankshaft seal (1) and pull the seal out.

Clean the crankshaft and seal surfaces. Tape the key groove on the crankshaft to avoid damaging the new seal during assembly.

3

Lubricate the new crankshaft seal with engine oil and put it on the crankshaft. Drive the seal into place with a suitable mandrel.

Remove the tape.

4

Install the pulley key on the crankshaft.

Install the pulley and tighten it to the specified torque with the center nut, please refer to the "Technical Data" chapter.

Install and adjust the drive belt.

Flat Rate: 21403**Valves, adjustment****Stationary, cold engine****1**

Remove the air filter housing (1) and valve housing (2).

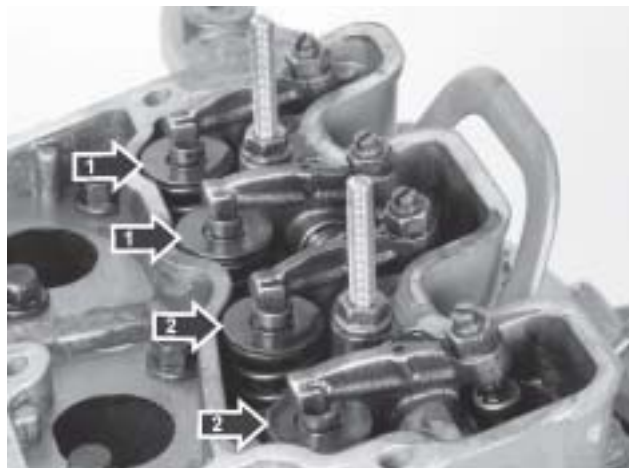
**2****D1-13**

Crank the engine clockwise until the valves (1) for no. 1 cylinder shift position. Then crank the engine exactly one more turn. You can now adjust the valves for no. 1 cylinder. Please refer to item 3 for the adjustment procedure.

Crank the engine until the valves (2) for no. 2 cylinder shift position. Then crank the engine exactly one more turn. Adjust the valves for no. 2 cylinder.

**D1-20, D1-30**

Crank the engine clockwise until the valves for no. 1 cylinder shift position. Adjust no. 2 inlet valve (1) and no. 3 exhaust valve (2). Please refer to item 3 for the adjustment procedure.

Crank the engine clockwise until the valves for no. 2 cylinder shift position. Adjust no. 3 inlet valve (3) and no. 1 exhaust valve (4).

Crank the engine clockwise until the valves for no. 3 cylinder shift position. Adjust no. 1 inlet valve (5) and no. 2 exhaust valve (6).

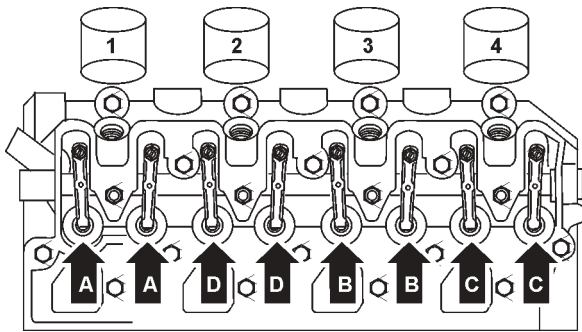
**D2-40**

Crank the engine clockwise until the valves for no. 4 cylinder shift position. Adjust no. 1 inlet and exhaust valve (A). Please refer to item 3 for the adjustment procedure.

Crank the engine clockwise until the valves for no. 2 cylinder shift position. Adjust no. 3 inlet and exhaust valve (B).

Crank the engine clockwise until the valves for no. 1 cylinder shift position. Adjust no. 4 inlet and exhaust valve (C).

Crank the engine clockwise until the valves for no. 3 cylinder shift position. Adjust no. 2 inlet and exhaust valve (D).

**3****Adjustment**

Undo the locknut (1) with a ring wrench. Measure the valve clearance (2) with a feeler gauge. Adjust the valve clearance with the adjustment screw (3).

The correct valve clearance for all valves and engines is 0.2 mm.

When the correct valve clearance has been reached, tighten the locknut (1).

4

Install the valve cover with a new seal.

Install the air filter housing.

Test run the engine and check that no oil leakage occurs.

Flat Rate: 23641

Drive belt, change

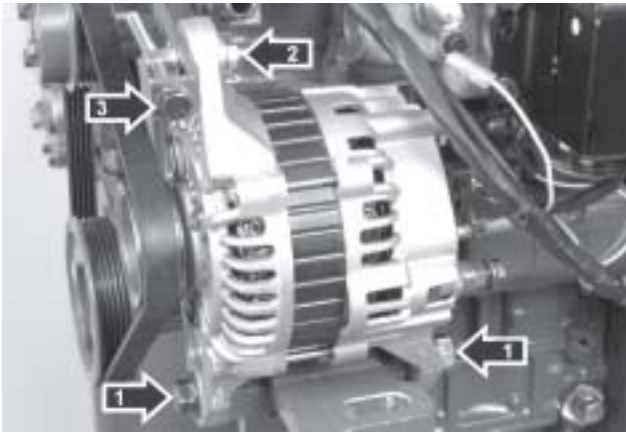
**1**

Lightly loosen the lower fixing screws (1) on the alternator. Loosen the upper fixing nut (2).

Loosen the tension screw (3) and slacken the drive belt. Remove the drive belt.

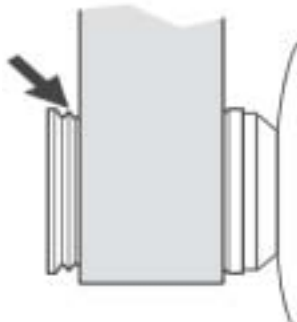

D1-30, D2-40

2

Install a new drive belt. Tension the belts with tensioner screw. Check the tension.

Tighten the alternator fixing nut and fixing screws.

⚠ IMPORTANT! D1-30, D2-40: Be careful to ensure that the alternator belt is placed in the groove closest to the alternator.

Oil pump bearing, changing

Timing gear and crankshaft removed

Special tools: 384 9639 (D1-13, D1-20), 384 9640 (D1-30, D2-40)



1

Drive out the oil pump bearing section (1) located in the engine block. Tap it out from inside the crankcase.

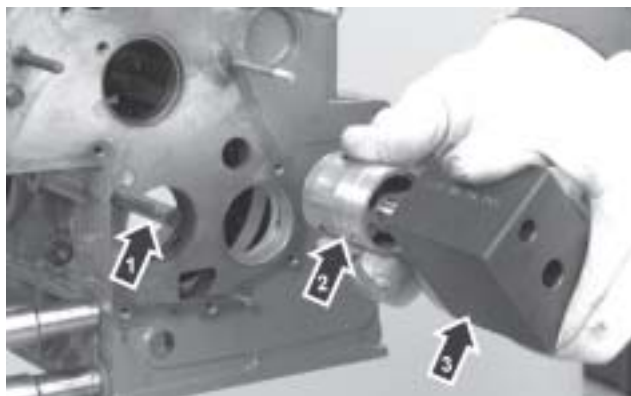

2

Use special tool 384 9639 for D1-13 and D1-20, 384 9640 for D1-30 and D2-40.

First screw the guide pin (1) for the tool into the engine block.

Then put the new oil pump bearing (2) into the tool block (3).

NOTE! It is important that the engine block surface touching the tool is clean and even. The tool block must be oiled.



3

Place the tool block with the bearing in place, using the guide pin.

Tap the bearing into place until the tool bottoms on the cylinder head.

Injection pump, changing

1

Unscrew the stop solenoid (1).

Undo the supply pipe (2) to the injection pump.

Undo the supply pipes (3) and return fuel pipe (4).

⚠ IMPORTANT! Seal all openings in the fuel system with protective caps.



2

Unscrew the injection pump (1). Lift it up until the lock clip (2) is accessible. Undo the clip and release the control rod (3).

Lift the injection pump out and remove the shim.

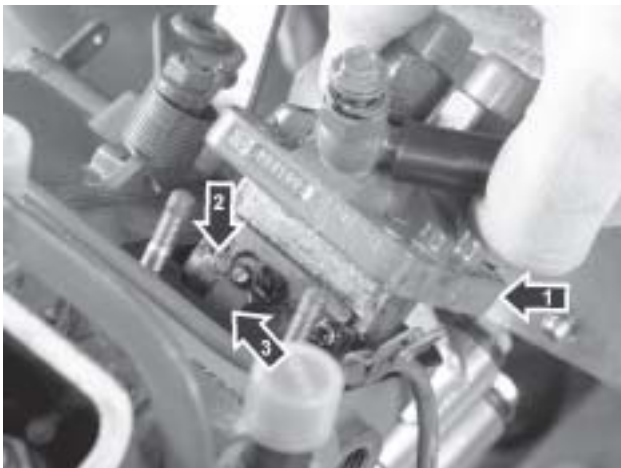

**3**

Put a new shim of the same thickness on the pump housing. Insert the new injection pump into the housing and fix the control rod with the lock clip.

Fix the oil supply pipe (1) on one of the studs (2). Tighten the injection pump to the specified torque, please refer to "Technical Data".

Install the supply pipe (3).

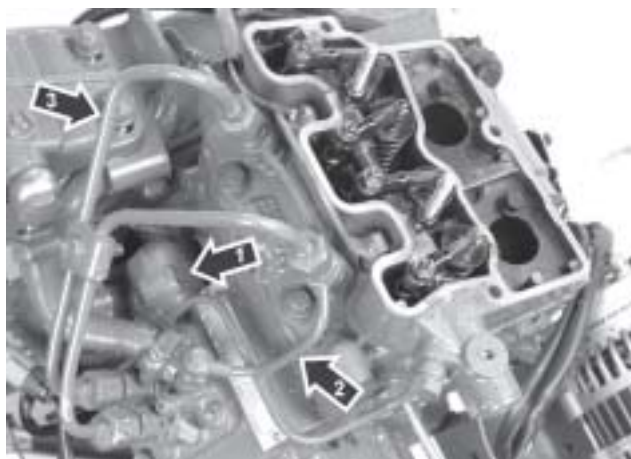
**5**

Install the stop solenoid (1) with a new seal.

Install the fuel return pipe (2).

Install the fuel supply pipes (3) and tighten to the specified torque, please refer to the "Technical Data" chapter.

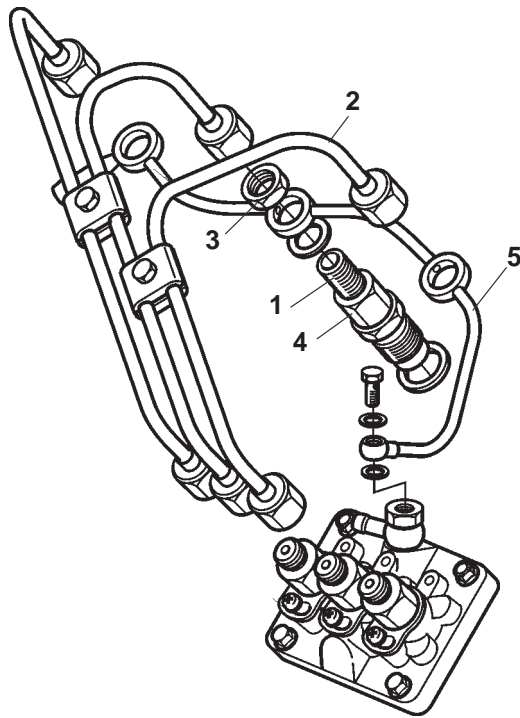

Flat Rate: 23710

Injectors, changing

1

Clean round the injectors (1).

Undo the fuel supply pipes (2) by the injection pump and the injectors. Lift the fuel supply pipes away together.

Remove the nut (3) at the top of each injector, use the nut (4) underneath the fuel return pipe (5) to avoid kinking the pipe. Lift the return fuel pipe away.

Unscrew the injectors. Remove the copper seals under the injectors.

⚠ IMPORTANT! Seal all openings in the fuel system with protective caps.

2

Install the new injectors with new copper seals. Apply sealant, part no. 840 879 to the two lowest threads (1). Tightening torque, please refer to the "Technical Data" chapter.

Install the new return fuel pipe, use the nut underneath the fuel return pipe to avoid kinking the pipe.

Install the fuel supply pipes. Check that they do not come out of alignment, and tighten the nuts. Tightening torque, please refer to the "Technical Data" chapter.

3

Start the engine and check that no leakage occurs.

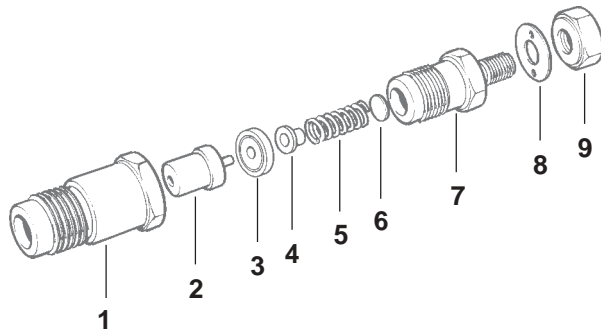

- | | |
|----------------------|-----------------------|
| 1. Injector nut | 6. Adjustment washers |
| 2. Injectors | 7. Injector holder |
| 3. Joining piece | 8. Washer |
| 4. Compression screw | 9. Nut |
| 5. Spring | |

Flat Rate: 23701

Renovating the injectors

1. Clean the outside of the injector.
2. Fix the injector (holder) in a vise. Unscrew the injector nut and take the injector apart.

Note. Be careful that the injector nozzle does not fall out during disassembly.

3. Pull the injector nozzle out of the injector sleeve and put the components in cleaning petrol (gasoline).

Note. Make sure that the injector needles and injector sleeves which belong with each other, and fit together, are not mixed up if several injectors are cleaned at the same time. To avoid mixing up, the injectors should be put in an injector stand or in different compartments.

4. Check each injector carefully with an illuminated magnifier or an injector microscope. Also check the other components.
5. When you install a **new injector**, it is important that conservation oil is washed off the injector needle and sleeve before the injector is assembled (avoid skin contact with the sliding surfaces of the needle).

Clean the components in chemically pure petrol (gasoline). Check that the injector needle slides in the sleeve, with no tendency to binding.

6. Dip the injector components in pure Diesel or testing oil, and fit the components together. Use the original thickness of adjustment washer(s) to set the opening pressure.
7. Check the opening pressure, jet pattern and sealing in an injector tester.

Injectors, testing

Testing is done in an injector tester. During the test, the opening pressure and sealing are the most important things. The spray pattern is more difficult to assess, and does not give a reliable indication of the injector's status.

⚠ WARNING! Be careful when testing injectors, avoid getting the fuel jet from an injector on unprotected parts of your body. The jet has such powerful penetration ability that it can force its way in under your skin and cause blood poisoning (septicemia).

Opening pressure

With the pressure gauge connected, press the injector tester lever down slowly until the injector opens and releases fuel. Read off the opening pressure at the opening instant.

If the value read does not coincide with the specified value, the setting must be changed. This is done with washers.

Note. The opening pressure is increased or reduced by about 1 MPa by a change in thickness of the spacer by 0.1 mm.

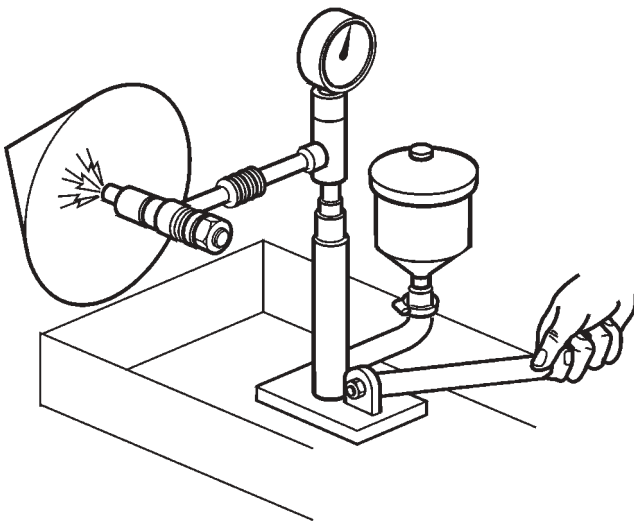

Injectors, check

Spray pattern

1. Pump the injector tester, special tool 9999 772, and check the injector spray pattern. The fuel jet should be conical and in line with the centerline of the injector. Fuel drops must not occur in the jet.
2. Check that the fuel jet has a circular cross section.

Sealing

When sealing is checked, investigate the fuel leakage which can occur between the injector nozzle seat and the tapered sealing surface in the injector sleeve.

1. Wipe the injector nozzle tip dry.
2. Pump the pressure up to about 2 MPa below the opening pressure of the injector (please refer to Technical Data). Keep the pressure constant for about 10 sec. and check that no fuel drips out from the tip of the injector. Damp injectors can be approved.

Install protective caps on the injector pipe couplings and over the injector nozzle tips, if the injectors will not be used at once.

Setting the engine speed

Check that the accelerator control functions normally, i.e. the actuator arm (1) is pressed against the low idle stop (2) when the accelerator control is at idle, and is pressed against the full throttle screw (3) when the accelerator control is at full throttle. Adjust the control if necessary. Also check that the air filter is not blocked, and that the air inlet is not blocked.

⚠ IMPORTANT! The engine's fuel volume and speed are set at the factory to give highest power and least environmental impact. These settings must not be disturbed.

NOTE! Seals on injection equipment may only be broken by authorized personnel. Seals which have been broken must be re-sealed.

Low idle

1. Check that the gap (6) is about 3 mm when the accelerator is in the idle position. If necessary: Undo lock nut (7) and adjust screw (8) to give the correct gap.
2. Warm the engine up and check the idling speed with a tachometer (please refer to Technical data for correct idling speed).
3. Use adjustment screw (2) to adjust to give the correct idling speed.
4. Check the gap (3) again as in item 1.

Racing speed (high idle)

Warm the engine up and check the racing speed with a workshop tachometer when the engine is unloaded at full throttle (please refer to "Technical data" for correct racing speed).

Adjust the following as necessary

1. Loosen the stop screw (3) so that it does not limit the movement of the actuator arm (1).
2. Run the engine without load at full throttle and adjust the racing speed to the correct value with adjustment screw (4). Remember to seal the screw afterwards.
3. Adjust stop screw (3) to give a clearance of 0.1 mm between stop screw (3) and the actuator arm (1) when the throttle control is at the full throttle position.

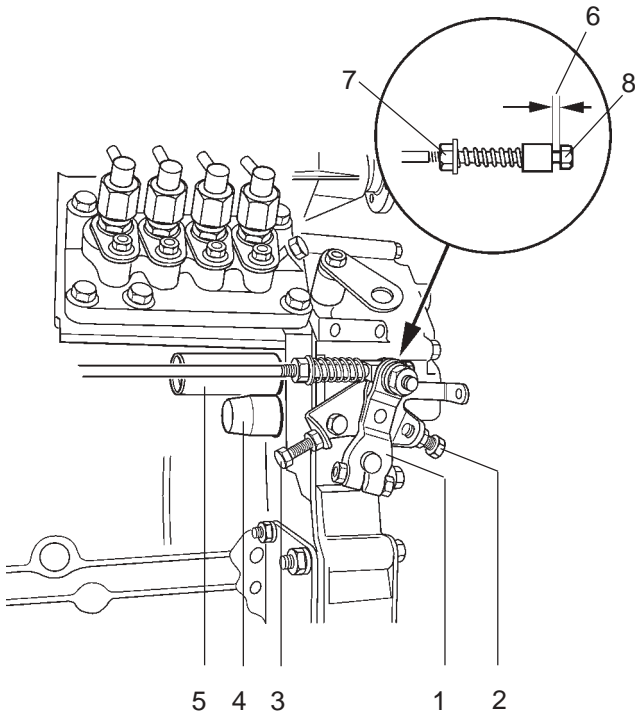

1. Actuator arm
2. Adjustment screw, low idle
3. Stop screw, full throttle
4. Adjustment screw, racing speed
5. Adjustment screw, max. fuel volume
7. Lock nut

Flat Rate: 23311

Feed pump, changing



1

Put a rag under the feed pump to collect spilled fuel.

Undo the unions (1) on the feed pump.

Unscrew the feed pump (2).

2

Put a new O-ring in the feed pump.

Install the feed pump and screw it in place.

Install the fuel unions on the feed pump.

Flat Rate: 23341

Hand pump, changing

**1**

Put a rag under the filter housing bracket to collect spilled fuel. Undo the secondary filter (1). This must be sorted as environmentally hazardous waste.

Undo the fuel unions (2).

Unscrew the hand pump (3) and remove it.

2

Put a new secondary filter in the new hand pump.

Install the hand pump on the bracket.

Screw the fuel unions tight.

Vent the fuel system, please refer to "Fuel System, Venting".

Flat Rate: 23080

Fuel system, venting

1

Open the vent screw (1) located above the fuel filter bracket.

NOTE! Check whether the copper washer on the vent screw needs to be changed.

2

Press the hand pump (2) located on the fuel filter bracket until fuel with no air bubbles comes out of the vent screw. Keep pumping at the same time as the vent screw is closed.

Pump another 10 strokes.

3

Wipe up the fuel that has run out.

Start the engine and check sealing.



Coolant

Mixing

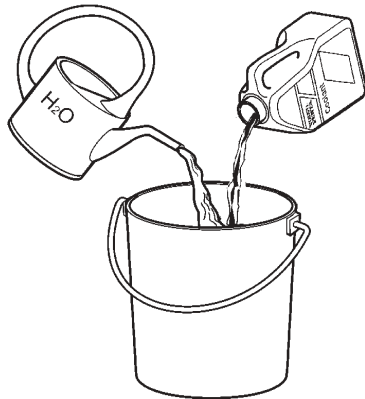

⚠ WARNING! All glycol is hazardous and pollutes the environment. Flammable. Do not swallow it!

Mix:
40% “Volvo Penta Coolant” (conc. coolant)
60% water

This mixture prevents against internal corrosion, cavitation and frost bursting down to about -28°C . (At 60% glycol concentration, the freezing point is lowered to -54°C .) Never mix more than 60% concentrate (Volvo Penta Coolant) in the coolant. This will give reduced frost protection and poorer cooling effect, with a consequent risk of overheating.

⚠ IMPORTANT! The coolant must be mixed with **pure water**, use **distilled – de-ionized water**.

⚠ IMPORTANT! It is extremely important that the correct concentration of coolant is put in the system. Mix in a separate clean vessel before filling the cooling system. Make sure that the liquids mix.

Filling the coolant

Flush the cooling system clean before new coolant is added.

Close all drain points and fill up with coolant to the correct level.

The engine must be stationary when the cooling system is filled, and must not be started until the system is vented and completely filled. If a heating unit is connected to the engine cooling system, the heat control valve should be fully opened and the installation vented during filling.

Check all hoses and joints, and rectify any leaks.

Fill the system slowly! Filling must not be done so fast that air locks are formed in the system. The air should be allowed to flow out through the filling opening. Check the coolant level after the engine has been run for about an hour. Top up with coolant as necessary.

Checking the coolant level

⚠ WARNING! Do not open the filler cap when the engine is warm, except in emergencies. Steam or hot fluid could spray out.

Turn the filler cap to the first stop and allow any excess pressure to hiss out before removing the cap completely. Top the coolant up as necessary. The level must be between the MAX and MIN markings.

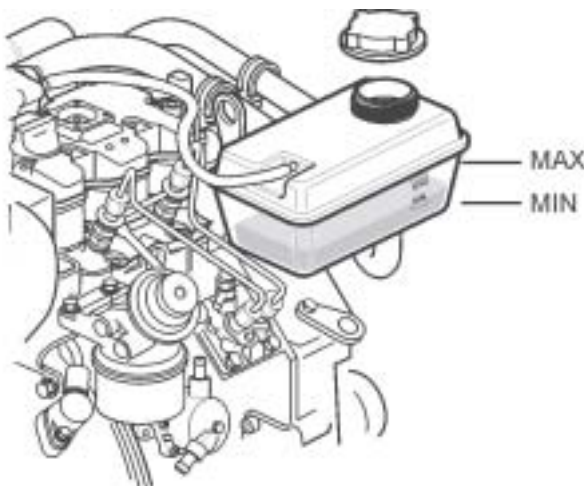

Pressure valve in filler cap, checking

Special tools: 9996662

1. Drain some of the coolant and connect the pressure testing device to a nipple or other plugged hole in the cooling system.
2. Extend the drain hose from the filler pipe with a hose which ends up in a water - filled vessel.
3. Increase the pressure and read the pressure gauge when the valve opens (water bubbles into the vessel with the drain hose). The valve should open at 0.075 MPa.
4. Remove the test equipment. Install the plug and fill the engine up with coolant.

Fault causes, cooling system

Too low coolant temperature

Low coolant temperature can be caused by:

- Faulty thermostat.
- Faulty temperature sensor or instrument.
- Low engine loading.

Excessive coolant temperature

Excessive coolant temperature (warning lamp lights up) can be caused by:

- Blocked sea water inlet or sea water filter.
- Defective impeller in the sea water pump.
- Too low coolant level, air in the fresh water system.
- Slipping or broken vee belt for the coolant pump.
- Faulty thermostat, temperature sensor or instrument.
- Blocked cooling system.
- Incorrectly set injection advance in the injection pump.
- Filler cap gasket does not seal.

Coolant losses

There are two types of coolant losses:

- Coolant losses during operation.
- Coolant losses after stopping a hot engine.

Coolant losses during operation can be caused by poor sealing in the cooling system, or that air or combustion gases are forced into the cooling system and force coolant out through the pressure cap.

Flat Rate: 26271

Thermostat, change

1

Drain the coolant.

Undo the thermostat housing (1). Remove the O-ring from the cap.

Remove the thermostat (2) and seal.

**2**

Install a new thermostat and seal.

Install the thermostat housing cover with a new O-ring. Tighten the screws to the specified torque, please refer to "Technical Data".

3

Fill up with coolant.

Warm up, and check the sealing and coolant level.

Heat exchanger, cleaning

Drained cooling system and sea water. Air filter housing removed. Expansion tank and bracket removed (D1-30 and D2-40)



1

Undo the heat exchanger end wall on the alternator side.

Remove the exhaust pipe elbow (1) and hose clamp (2) from the heat exchanger end wall. Remove the exhaust pipe elbow.

Undo the other end wall (3) from the heat exchanger.



2

Take the insert out (1) and scrap it.

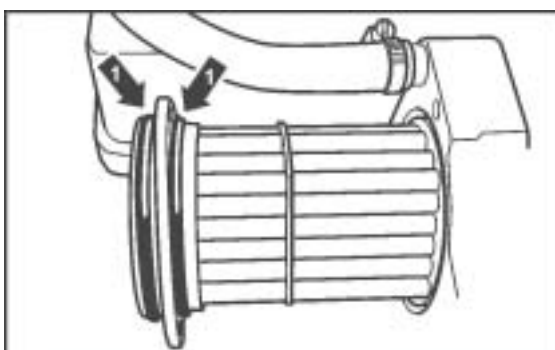

3

Install new O-rings (1) on the insert end wall.

Slide the insert in from the alternator side. Screw the end wall onto the heat exchanger.

4

Install new O-rings (2) on the insert and end wall.

Screw the end wall onto the heat exchanger.

Install the exhaust pipe bend.



5

Fill up with coolant. Check the fluid level and sealing after warming up.

Heat exchanger/exhaust manifold, changing

Current cut off with the main switch. Drained cooling system and sea water. Expansion tank and bracket removed (D1-30, D2-40).



1

Undo the hose union on the exhaust pipe elbow.
Unscrew the distribution box (1) and fold it to one side.



2

Undo the hose connections (1).
Undo the screws (2) and carefully prise the heat exchanger/exhaust manifold away.
Remove the gasket.

3

Clean the sealing surfaces of the cylinder head.
Transfer the exhaust pipe elbow to the new heat exchanger/exhaust manifold.
Install the new heat exchanger/exhaust manifold and gasket. Start to tighten the screws from the center and then outwards. Torque to 10 Nm.
Install the distribution box on the exhaust manifold.

4

Install the hose unions and junction to the exhaust pipe elbow.
Fill up with coolant.
Warm up, and check the sealing and coolant level.

Flat Rate: 26652

Seawater pump, impeller change

Close sea cock

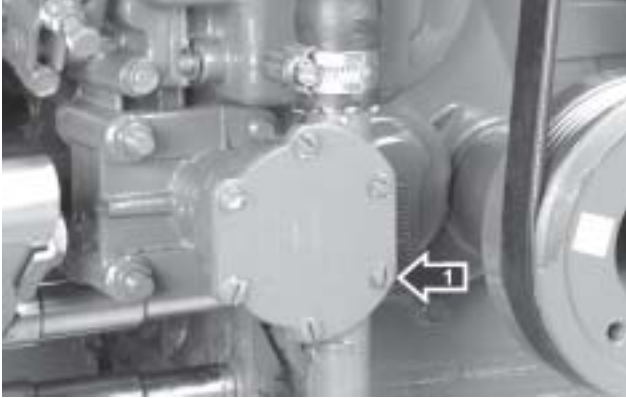

1

Unscrew all screws on the cover (1).



2

Remove the impeller (1) with water pump pliers.

3

Clean the pump housing and sealing surfaces.

4

Grease the new impeller and housing. Put the impeller and a new gasket in the housing.

Screw the cover down.

Open the sea cock and start the engine. Check the sealing.

Flat Rate: 26612

Sea water pump, change

Close sea cock

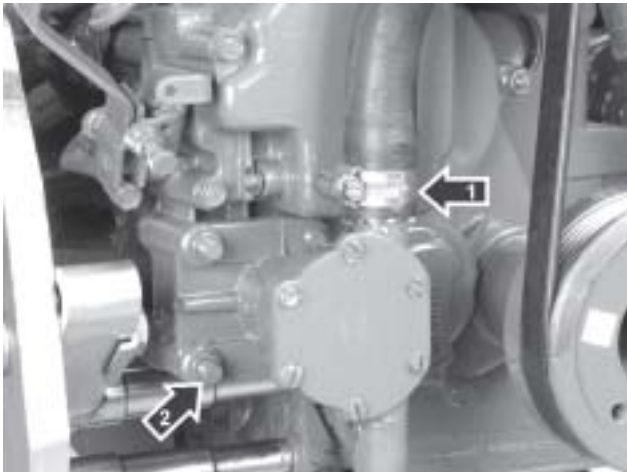

1

Undo the hose connections (1) for the seawater pump.
Undo the four screws (2) which hold the seawater pump.

2

Remove the seawater pump and the O-ring.
Check the mating surfaces.

NOTE! Check the seawater pump gear wheel. If it is damaged, the idler gear must be changed as well.

3

Install a new sea water pump and O-ring.
Install the screws and hose unions.

Open the sea cock and run the engine. Check the sealing.

Flat Rate: 26211

Coolant pump, change

1

Drain the coolant.

Undo the hose connections (1) for the coolant pump.

Loosen the tension (2) on the drive belt and remove it.



2

Undo the temperature sensor connector (1).

Loosen the screws (2) and nut (3) which hold the coolant pump and alternator stay (4).

Remove the coolant pump and alternator stay.

D1-13:

Also remove the spacer which is located between the coolant pump and engine block.

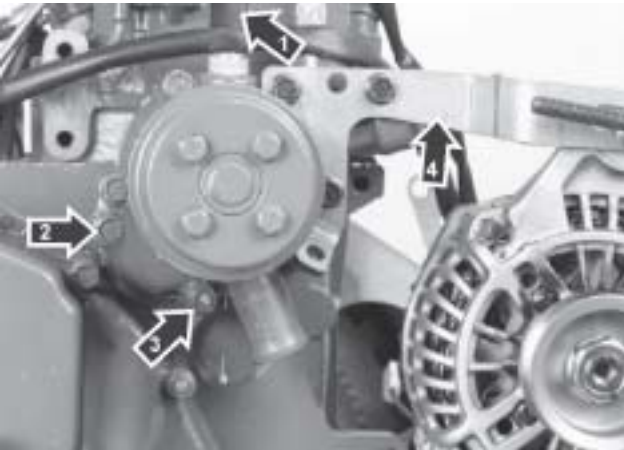

3

Clean the sealing surfaces.

Transfer the temperature sensor, hose union and pulley to the new coolant pump.

4

Install the new coolant pump with new seals, spacer (D1-13) and alternator stay.

Install and tension the drive belt.

Install the hose connections.

5

Fill up with coolant.

Warm up, and check the sealing and coolant level.

Flat Rate: 32111

Alternator, changing

Current cut off with the main switch

1

Mark and undo all electric connections to the alternator.

2

Loosen the upper fixing nut (1).

Undo the tension screw (2) to release the upper fixing screw (3) for the alternator.

Unscrew the lower fixing screw (4) and remove the alternator.

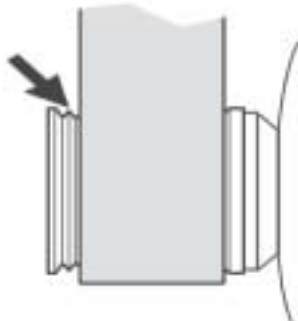
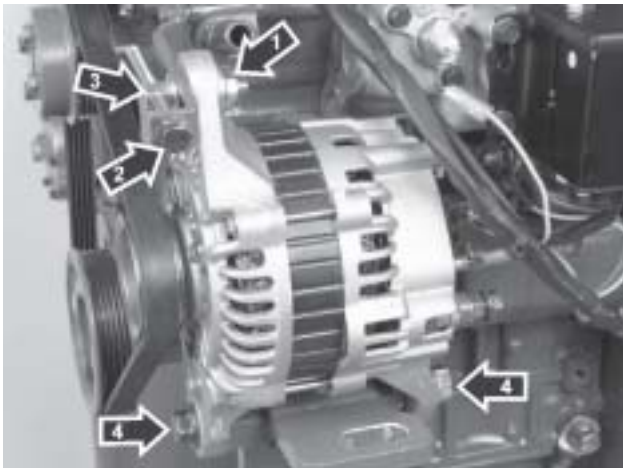

D1-30, D2-40

3

Put the new alternator in position and tighten the lower fixing screw. Tighten it loosely.

Put the upper fixing screw in position and lightly tighten the upper fixing nut. Screw the tension screw into the fixing screw.

Put the drive belt in place and tension it with the tension screw.

⚠ IMPORTANT! D1-30, D2-40: Be careful to ensure that the alternator belt is placed in the groove closest to the alternator.

4

After checking the drive belt tension, tighten the lower fixing screw and upper fixing nut.

Install the electric connections on the alternator.

Flat Rate: 33111

Starter motor, changing

Current cut off with the main switch. Alternator removed (D1-13).

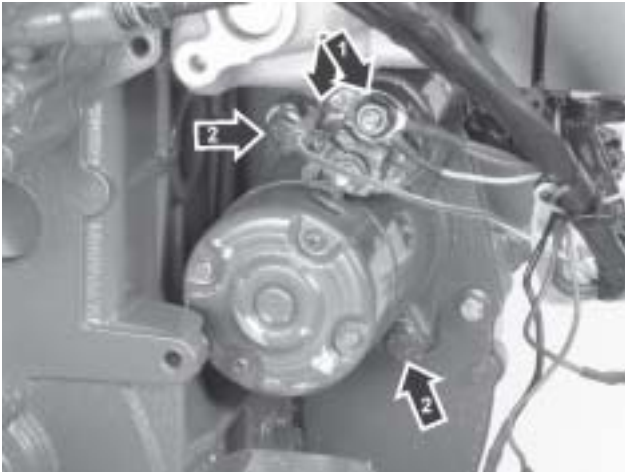

1

Undo all electric connections (1) to the start solenoid.

2

Undo the screws (2) which hold the starter motor.

Lift the starter motor out.

3

Put the new starter motor in position and fix it with the screws.

Install the electric connections on the starter motor.

4

Switch the current on and check the starter motor function.

Wiring diagram

Engine

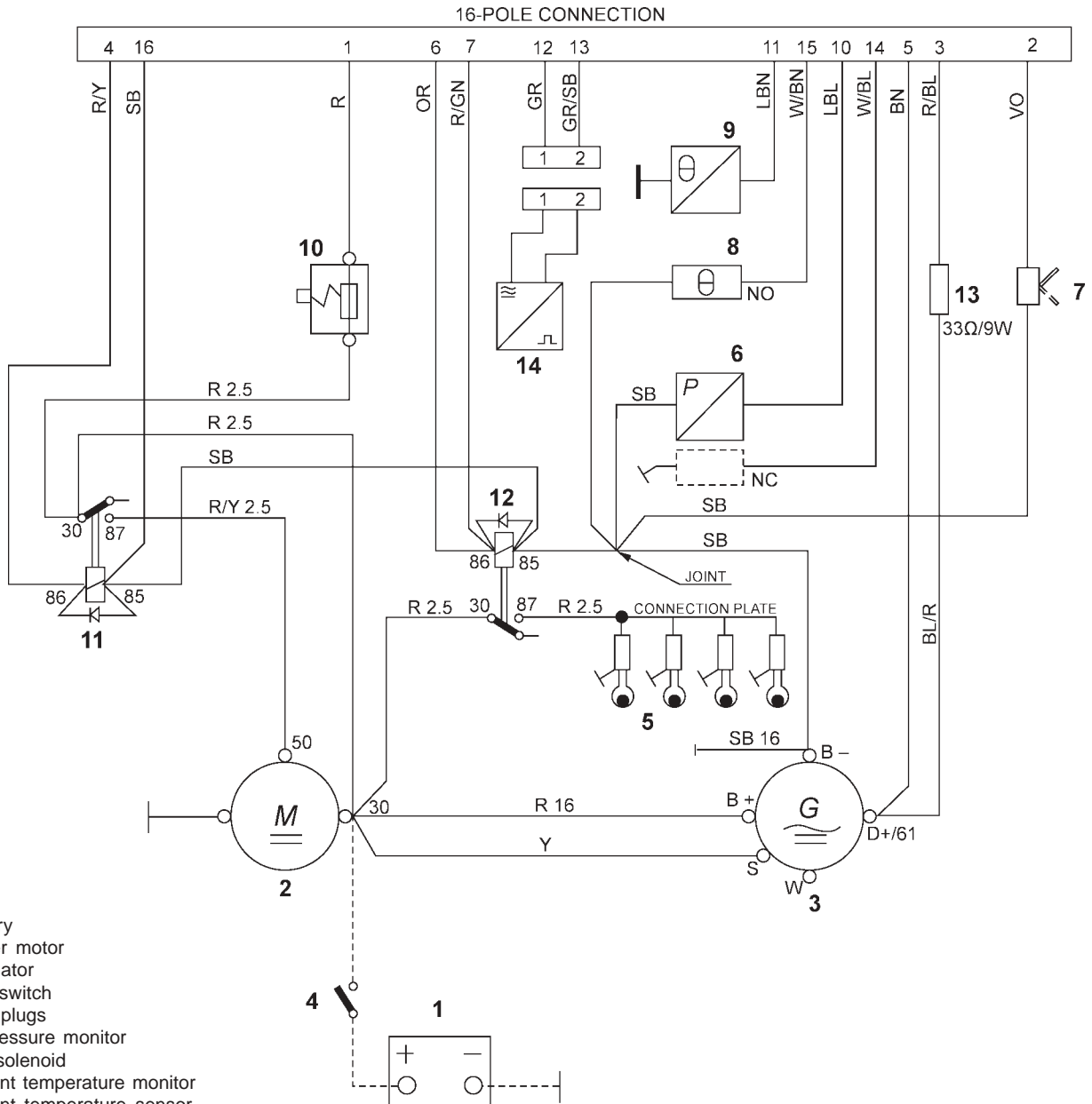

1. Battery
2. Starter motor
3. Alternator
4. Main switch
5. Glow plugs
6. Oil pressure monitor
7. Stop solenoid
8. Coolant temperature monitor
9. Coolant temperature sensor
10. Circuit breaker, 16 A
11. Starter relay
12. Glow plug relay
13. Charge sensing resistor, 33 Ohm/9W
14. Engine speed sensor

Cable colors

BL = Blue	OR = Orange
LBL = Light blue	R = Red
BN = Brown	SB = Black
LBN = Light brown	W = White
GN = Green	Y = Yellow
GR = Gray	

Cable areas in mm² are specified after the color code in the wiring schedule.

Cable areas not specified = 1.5 mm².

Cables shown with broken lines are not supplied by Volvo Penta.

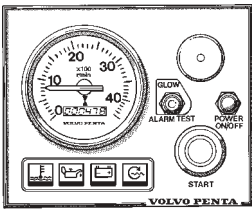

Instrument panel, alternative "A" *

* (without starter switch)

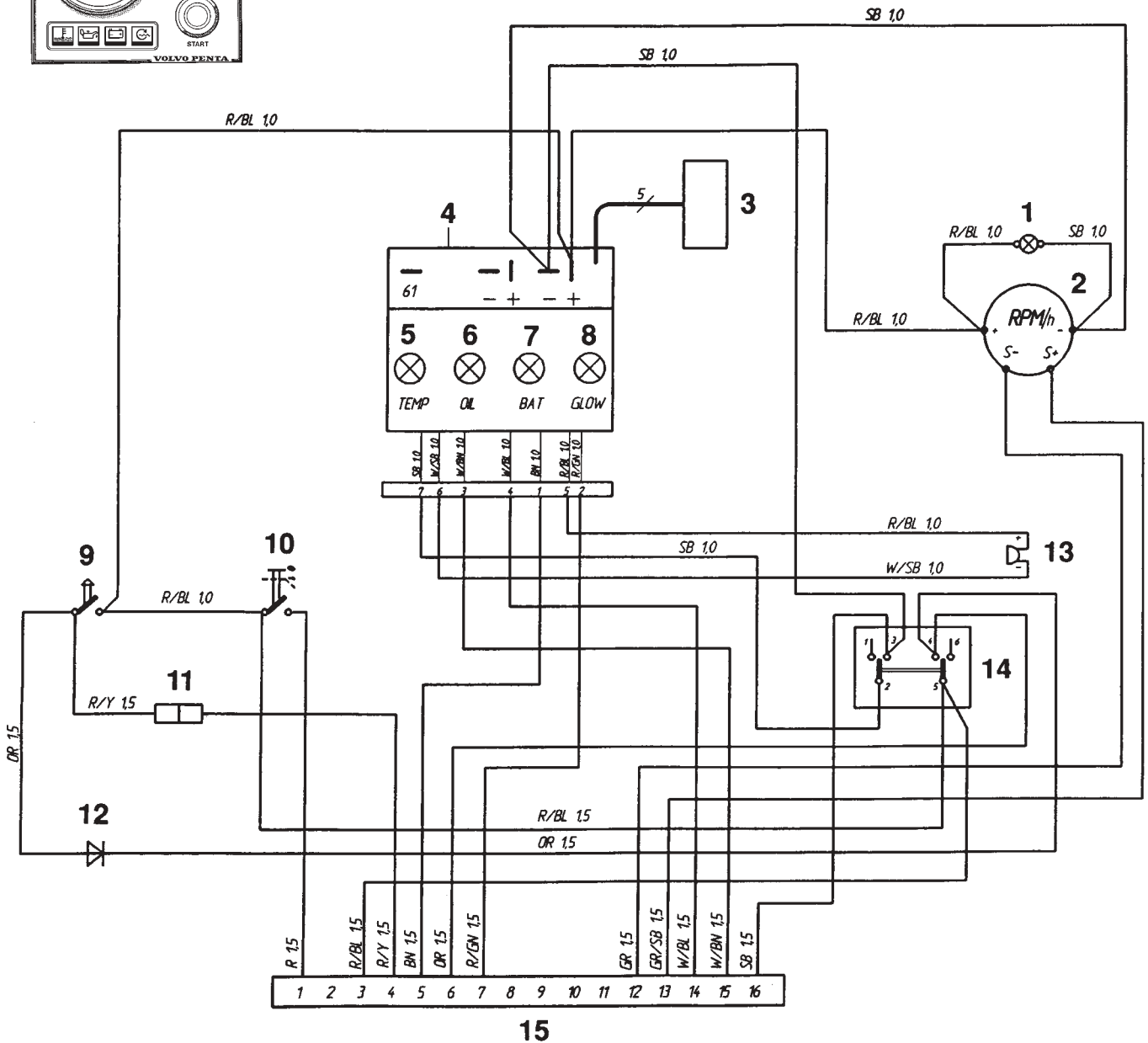

1. Instrument illumination
2. Tachometer with build-in hours counter (optional)
Or blanking plug
3. Connector for connecting extra warning display (optional equipment)
4. Electronic unit (alarm)
5. Warning lamp, coolant temperature
6. Warning lamp, oil pressure
7. Charge warning lamp
8. Indication lamp, glow plugs
9. Starter button
10. Press switch. Instrument panel, On/Off
11. Connector for connecting extra neutral position switch (optional equipment)
12. Semiconductor diode
13. Alarm
14. Tumbler switch. Glow plugs – Alarm test/Acknowledgment
15. 16-pin connector

Cable colors

- BL = Blue
- BN = Brown
- GN = Green
- GR = Gray
- OR = Orange
- PU = Purple
- R = Red
- SB = Black
- W = White
- Y = Yellow

Cable areas in mm² are specified after the color code in the wiring schedule.

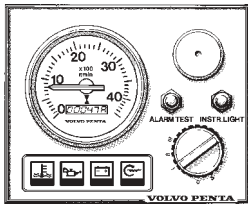

Instrument panel, alternative "B" *

* (with starter switch)

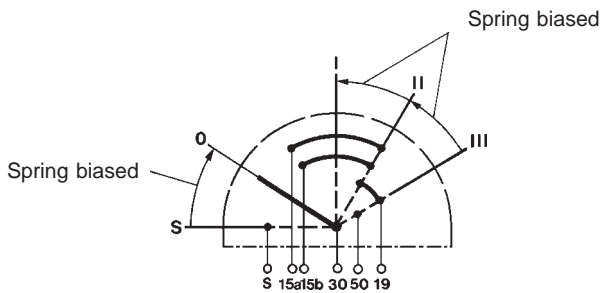
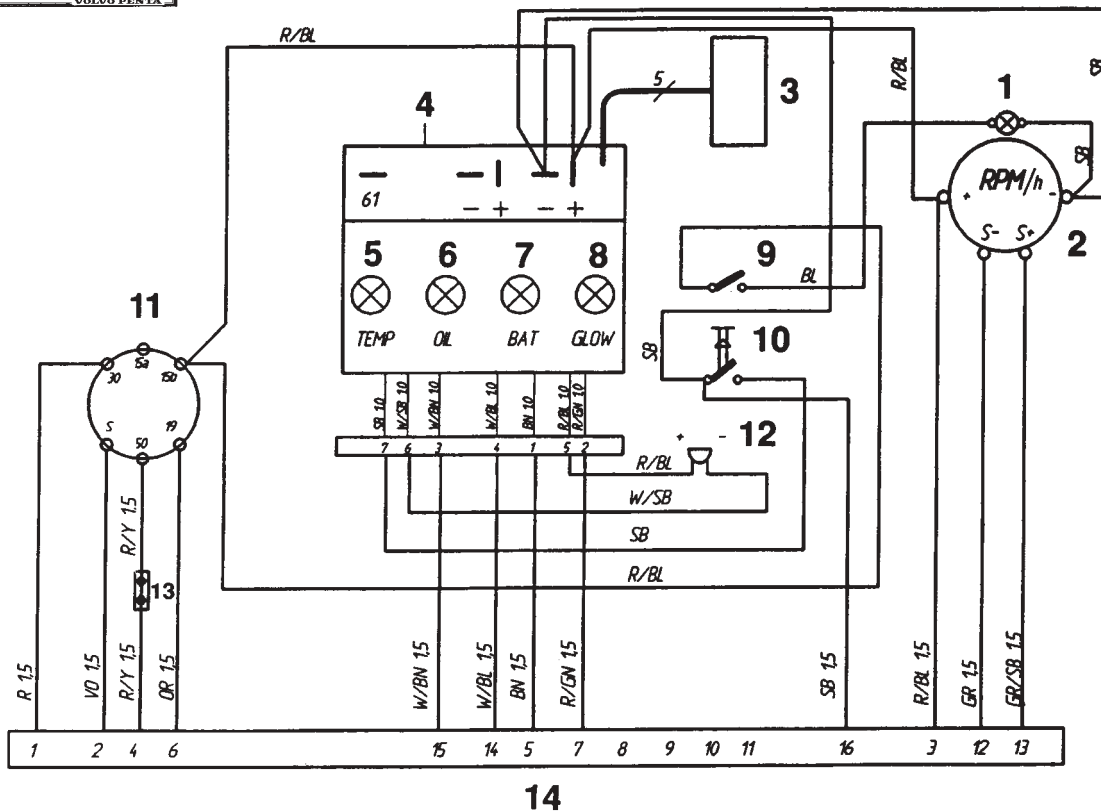

1. Instrument illumination
2. Tachometer with build-in hours counter (optional)
Or blanking plug
3. Connector for connecting extra warning display (optional equipment)
4. Electronic unit (alarm)
5. Warning lamp, coolant temperature
6. Warning lamp, oil pressure
7. Charge warning lamp
8. Indication lamp, glow plugs
9. Switch, instrument lighting
10. Switch - Alarm test/Acknowledgment
11. Key switch
12. Alarm
13. Connector for connection of neutral position switch (optional equipment)
14. 16-pin connector

Cable colors

- BL = Blue
- BN = Brown
- GN = Green
- GR = Gray
- OR = Orange
- R = Red
- SB = Black
- VO = Violet
- W = White
- Y = Yellow

Cable areas in mm² are specified after the color code in the wiring schedule.

Group 20 Technical data

General

	D1-13-A	D1-20-A	D1-30-A	D2-40-A
Engine designation	D1-13-A	D1-20-A	D1-30-A	D2-40-A
Number of cylinders	2	3	3	4
Cylinder diameter, mm (in)	67 (2.64)	67 (2.64)	77 (3.03)	77 (3.03)
Stroke length, mm (in)	72 (2.83)	72 (2.83)	81 (3.19)	81 (3.19)
Displacement, total litres (cu.in)	0.51 (31)	0.76 (46.5)	1.13 (69.1)	1.51 (92.1)
Power	See sales literature			
Idling speed, rpm	850 ±25			
Rated speed, rpm	3200			
Compression ratio	23.5:1	23.5:1	23:1	23.5:1
Compression at 250 rpm, repair limit, kPa (psi)	2450 (355)			
Firing order (highest cyl. No. closest to flywheel)	1-2	1-2-3	1-2-3	1-3-4-2
Direction of rotation see from front				Clockwise
Max. forward inclination				0°
Max. permissible angle backwards during operation				25°
Max. side angle during operation				35°
Valve clearance, idle cold engine:				
inlet and outlet, mm (in)				0.20 (0.008)
Weight, engine without oil and water, kg (lb)	96 (212)	118 (260)	127 (280)	148 (326)
Permitted backpressure in exhaust line, kPa (psi)	20 (2.9)			

Pistons

Material	Aluminium Alloy
Diameter, mm (in)	
D1-13-A, D1-20-A	66.9375 – 66.9525 (2.6353 – 2.6359)
Service limit	66.7 (2.6260)
D1-30-A, D2-40-A	76.932 – 76.947 (3.0288 – 3.0294)
Service limit	76.7 (3.020)
Piston clearance to the cylinder, mm (in)	
D1-13-A, D1-20-A	0.048 – 0.082 (0.0019 – 0.0032)
Service limit	0.25 (0,010)
D1-30-A, D2-40-A	0.0525 – 0.0865 (0.00210 – 0.00340)
Service limit	0.25 (0,010)
Front marking	The "SHIBAURA" name on the inside of the piston must be facing the fuel pump on assembly

Piston rings

Compression ring, number	2
Oil ring, number	1
Top compression ring:	
Clearance between groove and ring, all engines, mm (in)	0.06 – 0.10 (0.0024 – 0.0039)
Service limit, all engines, mm (in)	0.25 (0.0098)
Gap of piston ring, mm (in)	
D1-13-A, D1-20-A	0.13 – 0.25 (0.0051 – 0.0098)
D1-30-A, D2-40-A	0.15 – 0.27 (0.0059 – 0.0106)
Service limit, all engines, mm (in)	1.0 (0.039)
2nd compression ring:	
Clearance between groove and ring, all engines, mm (in)	0.05 – 0.09 (0.0020 – 0.0035)
Service limit, all engines, mm (in)	0.25 (0.0098)
Gap of piston ring, mm (in)	
D1-13-A, D1-20-A	0.10 – 0.22 (0.0039 – 0.0087)
D1-30-A, D2-40-A	0.12 – 0.24 (0.0047 – 0.0094)
Service limit, all engines, mm (in)	1.0 (0.039)

Oil ring:

Clearance between groove and ring, all engines, mm (in)	0.02 – 0.06 (0.0008 – 0.0024)
Service limit, all engines	0.15 (0.0059)
Gap of piston ring, mm (in)	
D1-13-A, D1-20-A	0.10 – 0.30 (0.0039 – 0.0118)
D1-30-A, D2-40-A	0.20 – 0.35 (0.0079 – 0.0138)
Service limit, all engines	1.0 (0.039)

Piston pins

Diameter, mm (in)	
D1-13-A, D1-20-A	18.998 – 19.002 (0.7480 – 0.7481)
Service limit	18.98 (0.7472)
D1-30-A, D2-40-A	20.996 – 21.002 (0.8266 – 0.8269)
Service limit	20.98 (0.826)
Clearance between hole and pin, all engines, mm (in)	–0.004 to +0.004 (–0.00016 to +0.00016)
Service limit	0.02 (0.0008)

Cylinder block

Diameter of the bore in the cylinder block, mm (in):

D1-13-A, D1-20-A	67.000 – 67.019 (2.6378 – 2.6385)
Service limit	67.200 (2.6457)
D1-30-A, D2-40-A	77.000 – 77.019 (3.0310 – 3.0320)
Service limit	77.200 (3.0390)
Flatness of the top of the cylinder block, mm (in)	Less than 0.05 (0.002)
Service limit	0.12 (0.005)

Cylinder head

Distortion of the cylinder head, mm (in)	0.00 – 0.05 (0.000 – 0.002)
Max. service limit, mm (in)	0.12 (0.005)
Max. limit for regrinding the cylinder head, mm (in)	0.15 (0.006)
Selection of cylinder head gasket:	
Piston height above top face of cylinder block, mm (in)	0.55 – 0.64 (0.0217 – 0.0252)
Choose gasket with thickness, mm (in)	1.2 (0.047)
Piston height above top face of cylinder block, mm (in)	0.65 – 0.75 (0.0256 – 0.0295)
Choose gasket with thickness, mm (in)	1.3 (0.051)

Rocker shaft

Diameter of the rocker shaft, mm (in):

D1-13-A, D1-20-A	9.950 – 9.968 (0.3917 – 0.3924)
Service limit	9.87 (0.3886)
D1-30-A, D2-40-A	11.65 – 11.67 (0.4587 – 0.4595)
Service limit	11.57 (0.4555)
Rocker arm clearance on the rocker shaft, mm (in):	
D1-13-A, D1-20-A, Min. permissible clearance	0.032 – 0.065 (0.00126 – 0.00260)
D1-30-A, D2-40-A, Min. permissible clearance	0.032 – 0.068 (0.00126 – 0.00268)
Max. permissible clearance, all engines	0.2 (0.008)

Crankshaft

Thrust washers:

Standard thickness, mm (in)	21.85 – 21.95 (0.8602 – 0.8642)
Service limit	21.60 (0.8504)

NOTE! The thrust washers is machined into the holder for the main bearing

Crankshaft end play, mm (in)	0.10 – 0.30 (0.0040 – 0.0118)
Service limit	0.50 (0.0197)

Crankshaft deflection, mm (in)	0.30 or less (0.0011)
Service limit	0.06 (0.0023)

Front crankshaft bush, diameter in mm (in), bearing journal :

Standard, D1-13-A and D1-20-A	42.964 – 42.975 (1.69150 – 1.69193)
Service limit	42.90 (1.6890)
Standard, D1-30-A and D2-40-A	47.965 – 47.975 (1.88830 – 1.88880)
Service limit	47.90 (1.8858)

NOTE! No undersize bush bearing journals are available

Main bearing journals

D1-13-A

Diameter in mm (in), standard, bearing journal

No. 1	42.964 – 42.975 (1.69150 – 1.69193)
Service limit	42.90 (1.6890)
No. 2	45.948 – 45.959 (1.80897 – 1.80941)
Service limit	45.90 (1.8071)

NOTE! No undersize main bearing journals are available

D1-20-A

Diameter in mm (in), standard, bearing journal

No. 1 and 2	42.964 – 42.975 (1.69150 – 1.69193)
Service limit	42.90 (1.6890)
No. 3	45.948 – 45.959 (1.80897 – 1.80941)
Service limit	45.90 (1.8071)

NOTE! No undersize main bearing journals are available

D1-30-A

Diameter in mm (in), standard, bearing journal

No. 1 and 2	47.965 – 47.975 (1.88830 – 1.88880)
Service limit	47.90 (1.8858)
No. 3	47.954 – 47.965 (1.88800 – 1.88830)
Service limit	47.90 (1.8858)

NOTE! No undersize main bearing journals are available

D2-40-A

Diameter in mm (in), standard, bearing journal

No. 1, 2 and 3	47.965 – 47.975 (1.88830 – 1.88880)
Service limit	47.90 (1.8858)
No. 4	47.954 – 47.965 (1.88800 – 1.88830)
Service limit	47.90 (1.8858)

NOTE! No undersize main bearing journals are available

Clearance between the main bearing and the main bearing journal, standard clearance:

D1-13-A, Journal No. 1	0.035 – 0.088 (0.0014 – 0.0035)
D1-13-A, Journal No. 2	0.039 – 0.092 (0.0015 – 0.0036)
D1-20-A, Journals No. 1 and 2	0.039 – 0.106 (0.0015 – 0.0042)
D1-20-A, Journal No. 3	0.039 – 0.092 (0.0015 – 0.0036)
D1-30-A, D2-40-A	0.039 – 0.106 (0.0015 – 0.0042)
Service limit, all engines	0.20 (0.0079)

Connecting rod bearing journals

D1-13-A, D1-20-A

Diameter in mm (in), bearing journal	
Standard	34.964 – 34.975 (1.3765 – 1.3770)
Service limit	34.90 (1.3740)

NOTE! No undersize rod bearing journals are available

D1-30-A, D2-40-A

Diameter in mm (in), bearing journal	
Standard	40.964 – 40.975 (1.6128 – 1.6132)
Service limit	40.90 (1.6102)

NOTE! No undersize rod bearing journals are available

Clearance between the connecting rod bearing and the connecting rod bearing journal, standard clearance:

D1-13-A, D1-20-A	0.031 – 0.079 (0.00122 – 0.00311)
D1-30-A, Journals No. 1 and 2	0.039 – 0.092 (0.00150 – 0.00360)
D1-30-A, Journal No. 3	0.029 – 0.082 (0.00110 – 0.00320)
D2-40-A	0.039 – 0.092 (0.00150 – 0.00360)
Service limit, all engines	0.20 (0.0079)

Connecting rods

Piston pin bearing:

Clearance between the piston pin and the piston pin bearing, mm (in)	0.010 – 0.025 (0.00040 – 0.00099)
Service limit, D1-13-A, D1-20-A	0.10 (0.004)
Service limit, D1-30-A, D2-40-A	0.08 (0.0031)

Connection rod bearing:

Clearance between the connecting rod bore and the connecting rod bearing, mm (in)	0.10 – 0.30 (0.004 – 0.012)
Service limit	0.70 (0.0276)

Camshaft

Drive	GearWheel
Height of the camshaft lobe for the inlet and outlet valves, all engines, mm (in)	26.955 – 27.010 (1.0612 – 1.0634)
Service limit	26.5 (1.0430)
Height of the camshaft lobe for the fuel injection pump, all engines, mm (in)	39.900 – 40.100 (1.5709 – 1.5787)
Service limit	39.8 (1.5669)
Height of the camshaft lobe for the fuel priming pump, all engines, mm (in)	27.900 – 28.000 (1.0984 – 1.1024)
Service limit	27.0 (1.0630)

Valves

Inlet

Spindle diameter in mm (in)	6.955 – 6.970 (0.27382 – 0.27441)
Service limit	6.89 (0.271)
Valve disc edge in mm (in)	0.925 – 1.075 (0.03642 – 0.04232)
Service limit	0.5 (0.02)
Valve depth below the cylinder head face in mm (in)	0.65 – 0.95 (0.0256 – 0.0374)
Service limit	1.8 (0.071)
Clearance in mm (in), valve spindle guide	0.025 – 0.052 (0.0010 – 0.0020)
Service limit	0.2 (0.008)
Seat angle in cylinder head	45°
Seat contact face in cylinder head	1.70 – 2.10 (0.0670 – 0.0830)
Service limit, mm (in)	2.5 (0.098)
Valve lash in mm (in), cold engine	0.20 (0.008)

Outlet

Spindle diameter in mm (in)	6.940 – 6.950 (0.27323 – 0.27362)
Service limit, mm (in)	6.84 (0.269)
Valve disc edge in mm (in)	0.925 - 1.075 (0.03642 - 0.04232)
Service limit, mm (in)	0.5 (0.02)
Valve depth below the cylinder head face in mm (in)	0.85 – 1.15 (0.0335 – 0.0453)
Service limit, mm (in)	1.8 (0.071)
Clearance in mm (in), valve spindle guide	0.045 – 0.072 (0.0020 – 0.0030)
Service limit, mm (in)	0.25 (0.010)
Seat angle in cylinder head	45°
Seat contact face in cylinder head	1.70 – 2.10 (0.0670 – 0.0830)
Service limit, mm (in)	2.5 (0.098)
Valve lash in mm (in), cold engine	0.20 (0.008)

Valve springs

Length in mm (in) uncompressed	35.0 (1.377)
Length in mm (in) with 79.4 N (58.56 ft.lbf) compression	30.4 (1.196)

Gear group

Max. backlash for all gears, mm (in)	0.25 (0.010)
Min. backlash for all gears, mm (in)	0.08 (0.003)

Lubrication system

Oil pressure in kPa (psi), hot engine at high idle	196 – 441 (28.4 – 64)
Oil pressure in kPa (psi), hot engine at low idle	>48 (7)
Relief valve, opening pressure in kPa (psi)	
D1-13-A, D1-20-A	352 – 448 (51 – 65)
D1-30-A, D2-40-A	304 – 500 (44 – 73)
Oil pump:	
Clearance, in mm (in), inner – outer rotor	0.01 – 0.15 (0.0004 – 0.0059)
Service limit	0.25 (0.0098)
Axial clearance between the face of oil pump cover and the face of the idler gear, in mm (in)	0.01 – 0.15 (0.0004 – 0.0059)
Service limit	0.20 (0.008)
Shims available for adjusting the axial clearance, mm	0.10, 0.15, 0.20, 0.50
Oil quality as per API system	VDS-2 ACEA E5 API CH-4
Viscosity at -5 to +50°C* (+23 to +122°F)*	SAE 15W/40 SAE 20W/50
Max. oil volume excl. oil filter, no engine tilt, litres (US gal):	
D1-13-A	1.9 (0.50)
D1-20-A	2.8 (0.74)
D1-30-A	3.5 (0.92)
D2-40-A	6.5 (1.72)
Oil change interval	
D1-13-A, D1-20-A, D1-30-A	200 h or 12 months
D2-40-A	500 h or 12 months

* **Note:** Temperatures with stable ambient temperature.

Fuel system

Feed pump max. suction height in m (ft)	0.8 (2.62)
Feed pressure in kPa (lbf/in ²)	15 – 25 (2.1 – 3.6)

Fuel injection pump

Type	In-line cassette			
Start of injection, crankshaft position, B.T.D.C				
D1-13-A, D1-20-A, D1-30-A	20° ±1°			
D2-40-A	22° ±1°			
	D1-13-A	D1-20-A	D1-30-A	D2-40-A
Pump element, diameter in mm (in)	5 (0.1968)	5 (0.1968)	6 (0.2362)	5.5 (0.2165)
Stroke length in mm (in)	6.5 (0.2559)	6.5 (0.2559)	6 (0.2362)	6 (0.2362)
Axial clearance between the face of oil pump cover and the face of the idler gear, in mm (in)	0.01 – 0.15 (0.0004 – 0.0059)			
Service limit	0.20 (0.008)			
Shims available for adjusting the axial clearance, mm	0.10, 0.15, 0.20, 0.50			

Injector

Opening pressure (checking), MPa (psi)	
D1-13-A, D1-20-A, D2-40-A	11.77 (1707)
D1-30-A	14.71 (2133)
Jet angle	4°

Exhaust system

Permitted Max. back pressure in the exhaust line at rated speed, all engines, kPa (psi)	20 (2.9)
--	----------

Cooling system

Type	Overpressure, closed cooling system
Fresh water system volume, approx, litres (US gal)	
D1-13-A	2.7 (0.71)
D1-20-A	3.0 (0.79)
D1-30-A	4.1 (1.08)
D2-40-A	6.4 (1.69)
Thermostat, number	1 st
Thermostat begins to open at	90°C (194°F)
fully open at	105°C (221°F)
Coolant, Glycol/water, mixing ratio	40/60

Electrical system

System voltage	12 V
Fuse (automatic)	16 A
Battery capacity (starter battery)	
D1-13-A, D1-20-A, D1-30-A	70 Ah
D2-40-A	88 Ah
Glow plug:	
rated voltage	11V
current	11A

Alternator

Output voltage at +20°C (+68°F)	14,2 ±0,15 V
Max. current	115 A
Suppressor capacitor	2.2 mikroF

Starter motor

Starter motor, power approx.	
D1-13-A, D1-20-A	0.8 kW
D1-30-A	1.1 kW
D2-40-A	1.4 kW

Tightening torque in Nm (ft.lbf)

Cylinder head*	
D1-13-A	36.5 (26.9)
D1-20-A	36.5 (26.9)
D1-30-A	51 (37.6)
D2-40-A	51 (37.6)
Main bearing:	
Bolts of the holder for the main bearing	23 (16.9)
Retaining bolts for the crankshaft	27 (19.9)
Connecting Rod:	
D1-13-A, D1-20-A	23 (17)
D1-30-A, D2-40-A	32 (23.6)
Front housing	10 (7.4)
Flywheel backplate:	
D1-13-A, D1-20-A	25 (18.4)
D1-30-A, D2-40-A	50 (36.9)
Flywheel housing	25 (18.4)
Flywheel	74 (55)
Crankshaft pulley:	
D1-13-A, D1-20-A	93 (68.6)
D1-30-A, D2-40-A	123 (90.7)
Flexible coupling	8.5 – 11.5 (6.3 – 8.5)
Suction strainer, oil pump	11 (8)
Sump	11 (8)
Drain plug, sump	34 (25)
Camshaft, setscrews for retainer plate	11 (8)
Rocker shaft housing:	
D1-13-A, D1-20-A	9.5 (7)
D1-30-A, D2-40-A	23 (17)
Valve mechanism cover:	
Setscrews	11 (8)
Cap nuts	10 (7.3)
Rocker arm locknut	14 (10)
Fuel injection pump:	
Mounting nuts and screws	6 (4.4)
Delivery valve holders	42 (31)
Pressure oil pipe (cylinder block–cylinder head)	12 (9)
Injector	64 (47.2)
Delivery pipe:	
D1-13-A, D1-20-A, D2-40-A	20 (14.8)
D1-30-A	23 (17)
Lock screw (max. fuel volume)	13 – 16 (9.6 – 11.8)
Lock screw (speed)	13 – 16 (9.6 – 11.8)
Exhaust manifold	10 (7.3)
Fuel shutoff solenoid	17 (13)
Fuel pump:	
Adjustment screw	2.5 (1.8)
Mounting screws	6 (4.4)
Glow plug	11.5 (8.5)
Oil pressure switch and adapter	11 (8)
Coolant temperature switch	27 (20)
Coolant drain plug (plastic)	3 (2.2)
Coolant thermostat housing	14 (10)
Oil relief valve	64 (47)
Starter motor, contacts	9.8 – 11.8 (7.2 – 8.7)

* The tightening torque given is the final tightening torque.
 The cylinder head should be tightened in three stages and in the correct sequence. See tightening procedure.
 On assembly lubricate cylinder head setscrews with clean oil.

General tightening torques in Nm

M5	5 Nm
M6	10 Nm
M7	17 Nm
M8	24 Nm
M10	50 Nm
M12	80 Nm
M14	130 Nm

Tightening sequence

Cylinder head

D2-40

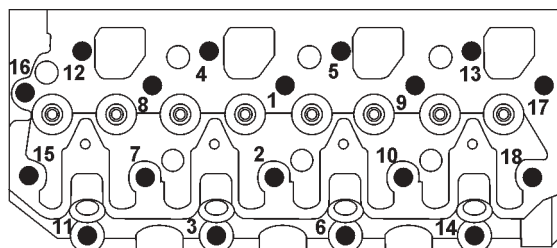

D1-20, D1-30

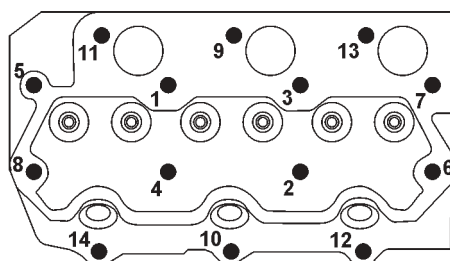

D1-13

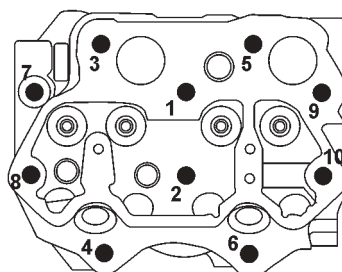

Conversion table

Metric to American or UK units:

American or UK to Metric units:

	To convert from	To	Multiply by	To convert from	To	Multiply by
Length	mm	inch	0.03937	inch	mm	25.40
	cm	inch	0.3937	inch	cm	2.540
	m	foot	3.2808	foot	m	0.3048
Area	mm ²	sq.in.	0.00155	sq. in.	mm ²	645.2
	m ²	sq. ft.	10.76	sq. ft.	m ²	0.093
Volume	cm ³	cu. in.	0.06102	cu. in.	cm ³	16.388
	liter, dm ³	sq. ft.	0.03531	cu. ft.	liter, dm ³	28.320
	liter, dm ³	cu. in.	61.023	cu. in.	liter, dm ³	0.01639
	liter, dm ³	imp. gallon	0.220	imp. gallon	liter, dm ³	4.545
	liter, dm ³	U.S. gallon	0.2642	U.S. gallon	liter, dm ³	3.785
	m ³	cu. ft.	35.315	cu.ft.	m ³	0.0283
Power	N	lbf	0.2248	lbf	N	4.448
Weight	kg	lb.	2.205	lb.	kg	0.454
Power	kW	hp (metric) ¹⁾	1.36	hp (metric) ¹⁾	1.36	0.735
	kW	bhp	1.341	bhp	kW	0.7457
	kW	BTU/min	56.87	BTU/min	kW	0.0176
Torque	Nm	lbf ft	0.738	lbf ft	Nm	1.356
Pressure	Bar	psi	14.5038	psi	Bar	0.06895
	MPa	psi	145.038	psi	MPa	0.006895
	Pa	mm Wg	0.102	mm Wg	Pa	9.807
	Pa	in Wc	0.004	in Wg	Pa	249.098
	kPa	in Wg	4.0	in Wg	kPa	0.24908
	mWg	in Wg	39.37	in Wg	mWg	0.0254
Energy	kJ/kWh	BTU/hph	0.697	BTU/hph	kJ/kWh	1.435
Work	kJ/kg	BTU/lb	0.430	BTU/lb	kJ/kg	2.326
	MJ/kg	BTU/lb	430	BTU/lb	MJ/kg	0.00233
	kJ/kg	kcal/kg	0.239	kcal/kg	kJ/kg	4.184
Fuel consumption	g/kWh	g/hph	0.736	g/hph	g/kWh	1.36
	g/kWh	lb/hph	0.00162	lb/hph	g/kWh	616.78
Inertia	kgm ²	lbft ²	23.734	lbft ²	kgm ²	0.042
Flow, gas	m ³ /h	cu.ft./min.	0.5886	cu.ft./min.	m ³ /h	1.699
Flow, fluid	m ³ /h	US gal/min	4.403	US gal/min	m ³ /h	0.2271
Speed	m/s	ft./s	3.281	ft./s	m/s	0.3048
	mph	knot	0.869	knot	mph	1.1508
Temp.	°F=9/5 x °C+32			°C=5/9 x (°F-32)		

1) All power noted in the catalogue refers to metric horsepower.

Notes

Notes

A series of horizontal dotted lines for writing notes.

Notes

A series of horizontal dotted lines for writing notes.

Report form

Do you have any comments or complaints about this manual? Please take a copy of this page, write your comments on it and send it to us. The address is at the bottom. We would appreciate it if you were to write in English or Swedish.

From:

.....

.....

.....

Refers to publication:

Publication no: Date of issue:

Suggestion/Motivation:

.....

.....

.....

.....

.....

.....

.....

.....

Date:

Name:

AB Volvo Penta
Technical Information
Dept. 42200
SE-405 08 Göteborg
Sweden

