

S.

**DISASSEMBLING AND SERVICING
DEMONTAGE ET ENTRETIEN
AUSBAU UND WARTUNG**

[1] ENGINE IDENTIFICATION

Model Name and Engine Serial Number

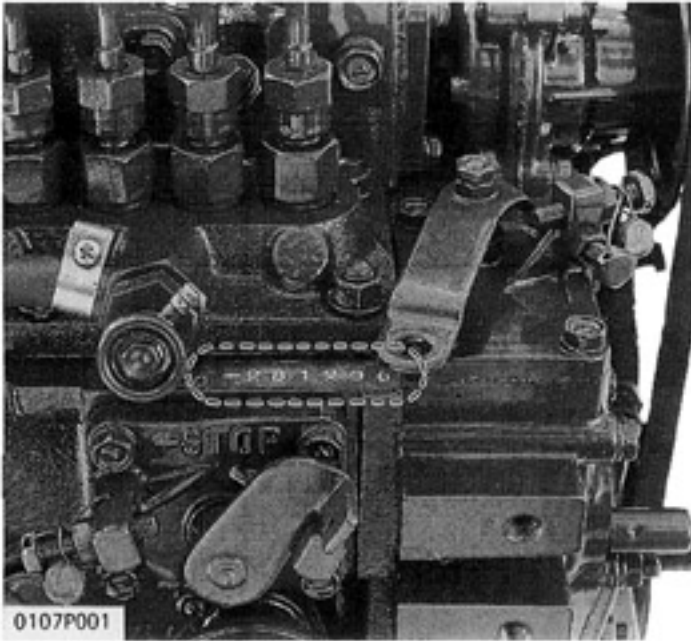

When contacting the manufacturer, always specify your engine model name and serial number.

Cylinder Number

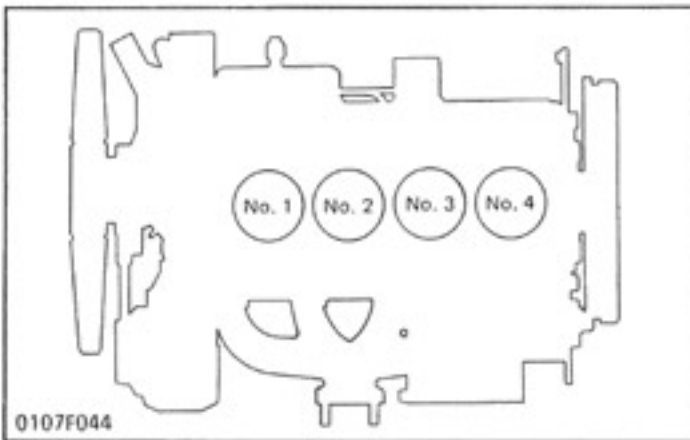

The cylinder numbers of 70 mm STROKE SERIES diesel engine are designated as shown in the figure.

The sequence of cylinder numbers is given as No.1, No.2, No.3 and No.4 starting from the gear case side.

[2] GENERAL PRECAUTION

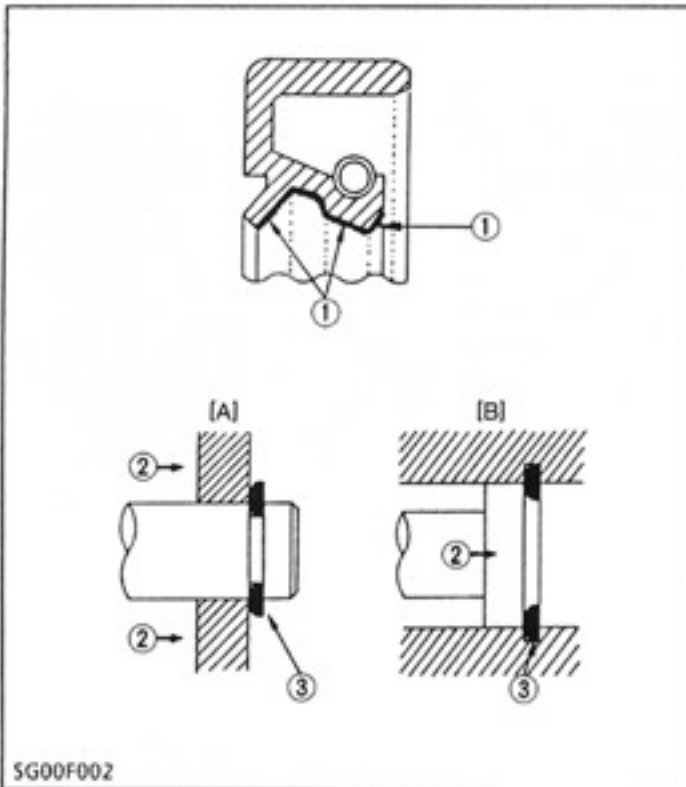

- During disassembly, carefully arrange removed parts in a clean area to prevent confusion later. Screws, bolts and nuts should be replaced in their original position to prevent reassembly errors.
- When special tools are required, use Kubota's genuine special tools. Special tools which are not frequently used should be made according to the drawings provided.
- Before disassembling or servicing live wires, make sure to always disconnect the grounding cable from the battery first.
- Remove oil and dirt from parts before measuring.
- Use only Kubota genuine parts for parts replacement to maintain engine performance and to ensure safety.
- Gaskets and O-rings must be replaced during reassembly. Apply grease to new O-rings or oil seals before assembling.
- When reassembling external or internal snap rings, position them so that the sharp edge faces against the direction from which force is applied.
- Be sure to perform run-in the serviced or reassembled engine. Do not attempt to give heavy load at once, or serious damage may result to the engine.

⚠ CAUTION

- Certain components used in this engine (cylinder head-gasket, exhaust gasket, etc.) contain asbestos. Handle with care according to safety regulation.

- (1) Grease
 (2) Force
 (3) Place the Sharp Edge against the Direction of Force

- [A] External Snap Ring
 [B] Internal Snap Ring

[3] TIGHTENING TORQUES

Screws, bolts and nuts must be tightened to the specified torque using a torque wrench, Several screws, bolts and nuts such as those used on the cylinder head must be tightened in proper sequence and at the proper torque.

(1) Tightening torques for special use screws, bolts and nuts

■ NOTE

- For "*" marked screws, bolts and nuts on the table, apply engine oil to their threads and seats before tightening.

| Item | Size x Pitch | N·m | kgf·m | ft-lbs |
|--|--------------|----------------|--------------|----------------|
| * Head cover cap nuts | M7 x 1.0 | 6.9 to 8.8 | 0.7 to 0.9 | 5.1 to 6.5 |
| * Head screws and nuts (Z500B, D650-B, D750-B only) | M8 x 1.25 | 39.2 to 44.1 | 4.0 to 4.5 | 28.9 to 32.5 |
| | M9 x 1.25 | 64.7 to 69.6 | 6.6 to 7.1 | 47.7 to 51.4 |
| * Bearing case screws 1 (with flange bolts) | M7 x 1.0 | 26.5 to 30.4 | 2.7 to 3.1 | 19.5 to 22.4 |
| (without flange bolts) | M7 x 1.0 | 19.6 to 23.5 | 2.0 to 2.4 | 14.5 to 17.4 |
| * Bearing case screws 2 | M8 x 1.25 | 29.4 to 34.3 | 3.0 to 3.5 | 21.7 to 25.3 |
| * Flywheel screws | M10 x 1.25 | 53.9 to 58.8 | 5.5 to 6.0 | 39.8 to 43.4 |
| * Connecting rod screws | M7 x 0.75 | 26.5 to 30.4 | 2.7 to 3.1 | 19.5 to 22.4 |
| * Rocker arm bracket nuts | M7 x 1.0 | 16.7 to 20.6 | 1.7 to 2.1 | 12.3 to 5.2 |
| * Idle gear shaft screws | M6 x 1.0 | 9.8 to 11.3 | 1.00 to 1.15 | 7.2 to 8.3 |
| Glow plugs | M10 x 1.25 | 19.6 to 24.5 | 2.0 to 2.5 | 14.5 to 18.1 |
| Drain plug | M12 x 1.25 | 39.2 to 49.0 | 4.0 to 5.0 | 28.9 to 36.2 |
| Nozzle holder assembly | M24 x 2.0 | 29.4 to 49.0 | 3.0 to 5.0 | 21.7 to 36.2 |
| Oil switch taper screw | PT 1/8 | 14.7 to 19.6 | 1.5 to 2.0 | 10.8 to 14.5 |
| Fuel limit lock nut | M12 x 1.0 | 27.5 to 34.3 | 2.8 to 3.5 | 20.3 to 25.3 |
| Fuel limit cap nut | M12 x 1.0 | 24.5 to 29.4 | 2.5 to 3.0 | 18.1 to 21.7 |
| Injection pipe retaining nuts | M12 x 1.5 | 14.7 to 24.5 | 1.5 to 2.5 | 10.8 to 8.1 |
| Nozzle holder and nozzle retaining nut | | 58.8 to 78.5 | 6.0 to 8.0 | 43.4 to 57.9 |
| Nozzle holder mounting screw | M24 x 2.0 | 39.2 to 49.0 | 4.0 to 5.0 | 28.9 to 36.2 |
| * Crankshaft nut | M20 x 1.5 | 137.3 to 156.9 | 14.0 to 16.0 | 101.3 to 115.7 |

(2) Tightening torques for general use screws, bolts and nuts

When the tightening torques are not specified, tighten the screws, bolts and nuts according to the table below.

| Nominal Diameter | Grade | Standard Screw and Bolt | | | Special Screw and Bolt | | |
|------------------|-------|-------------------------|--------------|--------------|------------------------|--------------|--------------|
| | Unit | N-m | kgf-m | ft-lbs | N-m | kgf-m | ft-lbs |
| M 6 | | 7.9 to 9.3 | 0.80 to 0.95 | 5.8 to 6.9 | 9.8 to 11.3 | 1.00 to 1.15 | 7.23 to 8.32 |
| M 8 | | 17.7 to 20.6 | 1.8 to 2.1 | 13.0 to 15.2 | 23.5 to 27.5 | 2.4 to 2.8 | 17.4 to 20.3 |
| M10 | | 39.2 to 45.1 | 4.0 to 4.6 | 28.9 to 33.3 | 48.1 to 55.9 | 4.9 to 5.7 | 35.4 to 41.2 |
| M12 | | 62.8 to 72.6 | 6.4 to 7.4 | 46.3 to 53.5 | 77.5 to 90.2 | 7.9 to 9.2 | 57.1 to 66.5 |

Screw and bolt material grades are shown by numbers punched on the screw and bolt heads. Prior to tightening, be sure to check out the numbers as shown below.

| Punched Number | Screw and Bolt Material Grade |
|----------------|---|
| None or 4 | Standard Screw and Bolt S541, S20C |
| 7 | Special Screw and Bolt S43C, S4BC (Refined) |

[4] TROUBLESHOOTING

| Symptom | Probable Cause | Solution | Reference Page |
|---|--|---|--|
| Engine does not start | <ul style="list-style-type: none"> ● No fuel ● Air in the fuel system ● Water in the fuel system ● Fuel pipe clogged ● Fuel filter clogged ● Excessively high viscosity of fuel or engine oil at low temperature ● Fuel with low cetane number ● Fuel leak due to loose injection pipe retaining nut ● Incorrect injection timing ● Fuel cam shaft worn ● Injection nozzle clogged ● Injection pump malfunctioning ● Seizure of crankshaft, camshaft, piston, cylinder liner or bearing ● Compression leak from cylinder ● Improper valve timing ● Piston ring and liner worn ● Excessive valve clearance | Replenish fuel Vent air Change fuel and repair or replace fuel system Clean Clean or change Use the specified fuel or engine oil Use the specified fuel Tighten nut Adjust Replace Clean Repair or replace Repair or replace Replace head gasket, tighten cylinder head bolt, glow plug and nozzle holder Correct or replace timing gear Replace Adjust | S-37 S-41 S-39 S-113 S-55 S-103 S-43 |
| Starter does not run | <ul style="list-style-type: none"> ● Battery discharged ● Starter malfunctioning ● Key switch malfunctioning ● Wiring disconnected | Charge Repair or replace Repair or replace Connect | |
| Engine revolution is not smooth | <ul style="list-style-type: none"> ● Fuel filter clogged or dirty ● Air cleaner clogged ● Fuel leak due to loose injection pipe retaining nut ● Injection pump malfunctioning ● Incorrect nozzle opening pressure ● Injection nozzle stuck or clogged ● Fuel over flow pipe clogged ● Governor malfunctioning | Clean or change Clean or change Tighten nut Repair or replace Adjust Repair or replace Clean Repair | S-37 S-41 S-115 |
| Either white or blue exhaust gas is observed | <ul style="list-style-type: none"> ● Excessive engine oil ● Piston ring and liner worn or stuck ● Incorrect injection timing ● Deficient compression | Reduce to the specified level Repair or replace Adjust Adjust top clearance | S-91 S-113 S-55, |
| Either black or dark gray exhaust gas is observed | <ul style="list-style-type: none"> ● Overload ● Low grade fuel used ● Fuel filter clogged ● Air cleaner clogged | Lessen the load Use the specified fuel Clean or change Clean or change | |
| Deficient output | <ul style="list-style-type: none"> ● Incorrect injection timing ● Engine's moving parts seem to be seizing ● Uneven fuel injection ● Deficient nozzle injection ● Compression leak | Adjust Repair or replace Repair or replace the injection pump Repair or replace the nozzle Replace head gasket, tighten cylinder head bolt, glow plug and nozzle holder | S-113 S-55 |

| Symptom | Probable Cause | Solution | Reference Page |
|-------------------------------------|---|--|---------------------------|
| Excessive lubricant oil consumption | <ul style="list-style-type: none"> ● Piston ring's gap facing the same direction ● Oil ring worn or stuck ● Piston ring groove worn ● Valve stem and guide worn ● Crankshaft bearing, and crank pin bearing worn | Shift ring gap direction Replace Replace the piston Replace Replace | S-75 S-93 S-101 |
| Fuel mixed into lubricant oil | <ul style="list-style-type: none"> ● Injection pump's plunger worn ● Injection pump broken | Replace pump element or pump Replace | S-113 |
| Water mixed into lubricant oil | <ul style="list-style-type: none"> ● Head gasket defective ● Cylinder block or cylinder head flawed | Replace Replace | |
| Low oil pressure | <ul style="list-style-type: none"> ● Engine oil insufficient ● Oil strainer clogged ● Relief valve stuck with dirt ● Relief valve spring weaken or broken ● Excessive oil clearance of crankshaft bearing ● Excessive oil clearance of crank pin bearing ● Excessive oil clearance of rocker arm bearing ● Oil passage clogged ● Different type of oil ● Oil pump defective | Replenish Clean Clean Replace Replace Replace Replace Clean Use the specified type of oil Repair or replace | S-71 S-39 |
| High oil pressure | <ul style="list-style-type: none"> ● Different type of oil ● Relief valve defective | Use the specified type of oil Replace | S-39 |
| Engine overheated | <ul style="list-style-type: none"> ● Engine oil insufficient ● Fan belt broken or elongated ● Cooling water insufficient ● Radiator net and radiator fin clogged with dust ● Inside of radiator corroded ● Cooling water flow route corroded ● Radiator cap defective ● Overload running ● Head gasket defective ● Incorrect injection timing ● Unsuitable fuel used | Replenish Change or adjust Replenish Clean Clean or replace Clean or replace Replace Loosen the load Replace Adjust Use the specified fuel | S-39 |
| Battery quickly discharge | <ul style="list-style-type: none"> ● Battery electrolyte insufficient ● Fan belt slips ● Wiring disconnected ● Rectifier defective ● Alternator defective ● Battery defective | Replenish distilled water and charge Adjust belt tension or change Connect Replace Replace Change | |

[5] SERVICING SPECIFICATIONS**(1) ENGINE BODY****Cylinder Head**

| Item | | Factory Specification | Allowable Limit |
|---|-----------|---|---|
| Cylinder head surface flatness | | - | 0.05 mm 0.0019 in. |
| Top clearance | | 0.6 to 0.8 mm 0.0237 to 0.0315 in. | - |
| Cylinder head gasket shim thickness | | 0.2 mm 0.0079 in. | - |
| Cylinder head gasket thickness (Grommet section) | Free | 1.15 to 1.30 mm 0.0453 to 0.0512 in. | - |
| | Tightened | 1.05 to 1.15 mm 0.0413 to 0.0453 in. | - |
| Compression pressure | | 31.5 kgf/cm ² 3.09 MPa, 448 psi | 23.7 kgf/cm ² 2.32 MPa, 337 psi |
| Variance among cylinders | | | 10% or less |

Valves

| | | | | |
|--|-----|---------------|---|----------------------|
| Valve clearance (Cold) | | | 0.145 to 0.185 mm 0.0057 to 0.0072 in. | - |
| Valve seat width | IN. | | 2.12 mm 0.0835 in. | - |
| | | VH1100-B only | 1.74 mm 0.0685 in. | - |
| | EX. | | 2.12 mm 0.0835 in. | - |
| Valve seat angle | IN. | | 45° 0.785 rad. | - |
| | | VH1100-B only | 60° 1.047 rad. | - |
| | EX. | | 45° 0.785 rad. | - |
| Valve face angle | IN. | | 45.5° 0.794 rad. | - |
| | | VH1100-B only | 60°15' 1.051 rad. | - |
| | EX. | | 45.5° 0.794 rad. | - |
| Valve recessing | | | 0.9 to 1.1 mm 0.036 to 0.043 in. | 1.3 mm 0.051 in. |
| Clearance between valve stem and valve guide | | | 0.035 to 0.065 mm 0.0014 to 0.0025 in. | 0.1 mm 0.0039 in. |
| Valve stem O.D. | | | 6.960 to 6.975 mm 0.2741 to 0.2746 in. | - |
| Valve guide I.D. | | | 7.010 to 7.025 mm 0.2760 to 0.2765 in. | - |

Valve Timing

| Item | | Factory Specification | Allowable Limit |
|---------------|-------|----------------------------------|-----------------|
| Intake valve | Open | 20° (0.35 rad.) before T.D.C. | – |
| | Close | 45° (0.79 rad.) after B.D.C. | – |
| Exhaust valve | Open | 50° (0.87 rad.) before B.D.C. | – |
| | Close | 15° (0.26 rad.) after T.D.C. | – |

Valve Spring

| | | |
|-------------------------------|--|--|
| Free length | 35.1 to 35.6 mm 1.382 to 1.401 in. | 34.8 mm 1.370 in. |
| Setting load / setting length | 7.5 kgf/31.0 mm 73.5 N/31.0 mm, 16.5 lbs/1.22 in. | 6.4 kgf/31.0 mm 62.8 N/31.0 mm, 14.1 lbs/1.22 in. |
| Tilt | – | 1.3 mm 0.051 in. |

Rocker Arm

| | | |
|--|---|-----------------------|
| Clearance between rocker arm shaft and bearing | 0.016 to 0.068 mm 0.0006 to 0.0027 in. | 0.12 mm 0.0047 in. |
| Rocker arm shaft O.D. | 10.973 to 10.984 mm 0.4320 to 0.4324 in. | – |
| Rocker arm bearing I.D. | 11.000 to 11.041 mm 0.4331 to 0.4347 in. | – |

Tappet

| | | |
|------------------------------------|---|----------------------|
| Clearance between tappet and guide | 0.020 to 0.062 mm 0.0008 to 0.0024 in. | 0.1 mm 0.0039 in. |
| Tappet O.D. | 19.959 to 19.980 mm 0.7858 to 0.7866 in. | – |
| Tappet guide I.D. | 20.000 to 20.021 mm 0.7874 to 0.7882 in. | – |

Camshaft

| | | |
|---------------------------|---|------------------------|
| Camshaft side clearance | 0.07 to 0.22 mm 0.0028 to 0.0087 in. | 0.3 mm 0.0118 in. |
| Camshaft alignment | – | 0.08 mm 0.0031 in. |
| Cam height (IN., EX.) | 26.88 mm 1.0583 in. | 26.83 mm 1.0563 in. |
| Oil clearance of camshaft | 0.050 to 0.091 mm 0.0020 to 0.0036 in. | 0.15 mm 0.0059 in. |
| Camshaft journal O.D. | 32.934 to 32.950 mm 1.2966 to 1.2972 in. | |
| Camshaft bearing I.D. | 33.000 to 33.025 mm 1.2992 to 1.3002 in. | |

Timing Gear

| Item | Factory Specification | Allowable Limit |
|--|---|----------------------|
| Timing gear backlash | 0.042 to 0.115 mm 0.0017 to 0.0045 in. | 0.2 mm 0.0079 in. |
| Idle gear side clearance | 0.20 to 0.51 mm 0.0079 to 0.0201 in. | 0.8 mm 0.0315 in. |
| Clearance between idle gear shaft and idle gear bushing | 0.016 to 0.045 mm 0.0006 to 0.0018 in. | 0.1 mm 0.0039 in. |
| Idle gear shaft O.D. | 17.973 to 17.984 mm 0.7076 to 0.7080 mm | — |
| Idle gear bushing I.D. | 18.000 to 18.018 mm 0.7087 to 0.7094 in. | — |
| Engine serial number: 407507 and beyond (Z500-B, Z600-B, ZH600-B, D650-B, D750-B, D850-B, DH850-B, V1100-B, VH1100-B, V1200-B) 393782 and beyond (D950-B) | | |
| Clearance between idle gear shaft and idle gear bushing | 0.020 to 0.054 mm 0.0008 to 0.0021 in. | 0.1 mm 0.0039 in. |
| Idle gear shaft O.D. | 23.967 to 23.980 mm 0.9436 to 0.9441 in. | — |
| Idle gear bushing I.D. | 24.000 to 24.021 mm 0.9449 to 0.9457 in. | — |
| Engine serial number: 599860 and beyond (Z500-B, Z600-B, ZH600-B, D650-B, D750-B, D850-B, DH850-B, D950-B, V1100-B, VH1100-B, V1200-B) | | |
| Clearance between idle gear shaft and idle gear bushing | 0.020 to 0.054 mm 0.0008 to 0.0021 in. | 0.1 mm 0.0039 in. |
| Idle gear shaft O.D. | 29.967 to 29.980 mm 1.1798 to 1.1803 in. | — |
| Idle gear bushing I.D. | 30.000 to 30.021 mm 1.1811 to 1.1819 in. | — |

Piston-Piston Ring

| | | |
|--|---|------------------------|
| Piston Pin Bore | 20.000 to 20.013 mm 0.7874 to 0.7879 in. | 20.03 mm 0.7886 in. |
| Clearance between compression ring 2 and ring groove | 0.085 to 0.112 mm 0.0033 to 0.0044 in. | 0.20 mm 0.0079 in. |
| Piston ring groove width | 1.555 to 1.570 mm 0.0613 to 0.0618 in. | — |
| Compression ring 2 width | 1.458 to 1.470 mm 0.0574 to 0.0579 in. | — |
| Clearance between oil ring and ring groove | 0.020 to 0.055 mm 0.0008 to 0.0021 in. | 0.20 mm 0.0079 in. |
| Piston ring groove width | 4.010 to 4.030 mm 0.1579 to 0.1587 in. | — |
| Oil ring width | 3.975 to 3.990 mm 0.1565 to 0.1571 in. | — |

Piston-Piston Ring (Continued)

| Item | | Factory Specification | Allowable Limit |
|----------|--------------------|---|-----------------------|
| Ring gap | Compression ring 1 | 0.25 to 0.40 mm 0.0098 to 0.0157 in. | 1.25 mm 0.0492 in. |
| | | D950-B, V1200-B only 0.20 to 0.35 mm 0.0079 to 0.0138 in. | |
| | Compression ring 2 | 0.25 to 0.40 mm 0.0098 to 0.0157 in. | 1.25 mm 0.0492 in. |
| | | D950-B only 0.30 to 0.45 mm 0.0118 to 0.0177 in. | |
| | Oil ring | 0.25 to 0.40 mm 0.0098 to 0.0157 in. | 1.25 mm 0.0492 in. |
| | | D650-B, D750-B only 0.20 to 0.40 mm 0.0079 to 0.0157 in. | |

Connecting Rod

| | | |
|--|---|-----------------------|
| Connecting rod alignment | – | 0.05 mm 0.0020 in. |
| Clearance between piston pin and small end bushing | 0.014 to 0.038 mm 0.0006 to 0.0015 in. | 0.15 mm 0.0059 in. |
| Piston pin O.D. | 20.002 to 20.011 mm 0.7875 to 0.7878 in. | – |
| Small end bushing I.D. | 20.025 to 20.040 mm 0.7884 to 0.7890 in. | – |

Crankshaft

| | | |
|---|---|-----------------------|
| Crankshaft alignment | 0.02 mm 0.008 in. | 0.08 mm 0.0031 in. |
| Oil clearance between crankshaft and crankshaft bearing 1 | 0.034 to 0.106 mm 0.0013 to 0.0042 in. | 0.2 mm 0.0079 in. |
| Crankshaft O.D. | 43.934 to 43.950 mm 1.7297 to 1.7303 in. | – |
| Crankshaft bearing 1 I.D. | 43.984 to 44.040 mm 1.7317 to 1.7339 in. | – |
| Oil clearance between crankshaft and crankshaft bearing 2 | 0.034 to 0.092 mm 0.0013 to 0.0036 in. | 0.2 mm 0.0079 in. |
| Crankshaft O.D. | 43.934 to 43.950 mm 1.7297 to 1.7303 in. | – |
| Crankshaft bearing 2 I.D. | 43.984 to 44.026 mm 1.7317 to 1.7333 in. | – |
| Oil clearance between crank pin and crank pin bearing | 0.029 to 0.087 mm 0.0011 to 0.0034 in. | 0.2 mm 0.0079 in. |
| Crank pin O.D. | 36.959 to 36.975 mm 1.4551 to 1.4557 in. | – |
| Crank pin bearing I.D. | 37.004 to 37.046 mm 1.4569 to 1.4585 in. | – |
| Crankshaft side clearance | 0.15 to 0.31 mm 0.0059 to 0.0122 in. | 0.5 mm 0.0197 in. |
| Crankshaft sleeve wear | – | 0.1 mm 0.0039 in. |

Cylinder Liner

| Item | Factory Specification | Allowable Limit |
|-------------------------------|--|-------------------------|
| Cylinder liner I.D. | 64.000 to 64.019 mm 2.5197 to 2.5204 in. 68.000 to 68.019 mm 2.6772 to 2.6779 in. 72.000 to 72.019 mm 2.8347 to 2.8354 in. 75.000 to 75.019 mm 2.9528 to 2.9535 in. | + 0.15 mm 0.0059 in. |
| Oversized cylinder liner I.D. | + 0.5 mm 0.0197 in. | |

(2) LUBRICATING SYSTEM**Oil Pump**

| | | | | |
|---|----------------|--------------------------|--|--|
| Engine oil pressure | At idle speed | | 0.7 kgf/cm ² 68 kPa, 10 psi | — |
| | At rated speed | | 2.0 to 4.5 kgf/cm ² 196 to 441 kPa, 29 to 64 psi | 2.0 kgf/cm ² 196 kPa, 29 psi |
| | | V1100-B, V1200-B only | 1.7 to 3.5 kgf/cm ² 167 to 343 kPa, 24 to 49 psi | 1.7 kgf/cm ² 167 kPa, 24 psi |
| Clearance between inner rotor and outer rotor | | | 0.11 to 0.15 mm 0.0043 to 0.0059 in. | 0.2 mm 0.0079 in. |
| Clearance between outer rotor and pump body | | | 0.07 to 0.15 mm 0.0028 to 0.0059 in. | 0.25 mm 0.0098 in. |
| End clearance between inner rotor and cover | | | 0.08 to 0.13 mm 0.0031 to 0.0051 in. | 0.2 mm 0.0079 in. |

(3) COOLING SYSTEM**Thermostat**

| | | |
|--|------------------------------------|---|
| Thermostat's valve opening temperature | 80.5 to 83.5°C 176.9 to 182.3°F | — |
| Temperature at which thermostat completely opens | 95°C 203°F | — |

Radiator

| | | |
|--------------------------|---|---|
| Radiator water tightness | Water tightness at specified pressure 1.4 kgf/cm ² 137 kPa, 20 psi | — |
| Radiator cap air leakage | 10 seconds or more 0.9 — 0.6 kgf/cm ² 88 — 59 kPa, 13 — 9 psi | — |
| Fan belt tension | 7 to 9 mm/10 kgf 0.28 to 0.35 in./10 kgf (22.1 lbs.) | — |

(4) FUEL SYSTEM**Injection Pump**

| Item | Factory Specification | Allowable Limit |
|----------------------------------|--|--|
| Injection timing | 23° to 25° before T.D.C. (0.402 to 0.436 rad.) | — |
| Fuel tightness of pump element | — | 150 kgf/cm ² 14.7 MPa, 2133 psi |
| Fuel tightness of delivery valve | More 10 seconds 150 → 140 kgf/cm ² 14.7 → 13.7 MPa 2133 → 1990 psi | 5 seconds 150 → 140 kgf/cm ² 14.7 → 13.7 MPa 2133 → 1990 psi |

Injection Nozzle

| | | |
|-------------------------------------|--|---|
| Fuel injection pressure | 140 to 150 kgf/cm ² 13.73 to 14.71 MPa 1991 to 2133 psi | — |
| Fuel tightness of nozzle valve seat | When the pressure is 130 kgf/cm ² (12.75 MPa, 1849 psi), the valve seat must be fuel tightness. | — |

(5) ELECTRICAL SYSTEM**Starter**

| | | | |
|-----------------|----------|---------------------------------------|-----------------------|
| Commutator O.D. | (1 kW) | 30.0 mm 1.1811 in. | 29.0 mm 1.1417 in. |
| | (0.8 kW) | 28.0 mm 1.1024 in. | 27.0 mm 1.0630 in. |
| Mica undercut | | 0.5 to 0.8 mm 0.0197 to 0.0315 in. | 0.2 mm 0.079 in. |
| Brush length | (1 kW) | 13.0 mm 0.5118 in. | 8.5 mm 0.3346 in. |
| | (0.8 kW) | 16.0 mm 0.6299 in. | 10.5 mm 0.4134 in. |

Alternator

| | | |
|-----------------|---------------------|---|
| No-load voltage | AC 20 V at 5200 rpm | — |
|-----------------|---------------------|---|

Glow Plug

| | | |
|----------------------|--------------|---|
| Glow plug resistance | 1.0 to 1.2 Ω | — |
|----------------------|--------------|---|

[6] MAINTENANCE CHECK LIST

To maintain long-lasting and safe engine performance, make it a rule to carry out regular inspections by following the table below.

| Item | Service Interval | | | | | | | | | |
|---------------------------------------|------------------|---------------|---------------|---------------|---------------|----------------|--------------------|----------------|-----------------|---|
| | Every 50 hrs | Every 100 hrs | Every 150 hrs | Every 400 hrs | Every 800 hrs | Every 1000 hrs | Every three months | Every one year | Every two years | |
| Checking fuel pipes and clamps | ○ | | | | | | | | | |
| Changing engine oil * | | ○ | | | | | | | | |
| Cleaning air filter element | | ○ | | | | | | | | |
| Cleaning fuel filter | | ○ | | | | | | | | |
| Checking fan belt tension and damage | | ○ | | | | | | | | |
| Checking water pipes and clamps | | | ○ | | | | | | | |
| Changing oil filter cartridge | | | ○ | | | | | | | |
| Changing fuel filter element | | | | ○ | | | | | | |
| Cleaning radiator interior | | | | ○ | | | | | | |
| Changing radiator cleaner and coolant | | | | | | | ○ | | | |
| Changing air filter element | | | | | | | | ○ | | |
| Checking valve clearance | | | | | ○ | | | | | |
| Checking nozzle injection pressure | | | | | | ○ | | | | |
| Changing water pipes and clamps | | | | | | | | | | ○ |
| Changing fuel pipes and clamps | | | | | | | | | | ○ |

* Change engine oil after the first 35 hours of operation.

CAUTION

- When changing or inspecting, be sure to level and stop the engine.

[7] CHECK AND MAINTENANCE

(1) Daily Check Points

Checking Engine Oil Level

1. Level the engine.
2. To check the oil level, draw out the dipstick, wipe it clean, reinsert it, and draw it out again.
Check to see that the oil level lies between the two notches.
3. If the level is too low, add new oil to the specified level.

■ IMPORTANT

- When using an oil of different maker or viscosity from the previous one, drain old oil. Never mix two different types of oil.

Checking and Replenish Cooling Water

1. Remove the radiator cap and check to see that the cooling water level is just below the port.
2. If low, add clean water and antifreeze.



CAUTION

- Do not remove the radiator cap until cooling water temperature is below its boiling point. Then loosen the cap slightly to relieve any excess pressure before removing the cap completely.

■ IMPORTANT

- Be sure to close the radiator cap securely. If the cap is loose or improperly closed, water may leak out and the engine could overheat.
- Do not use an antifreeze and scale inhibitor at the same time.

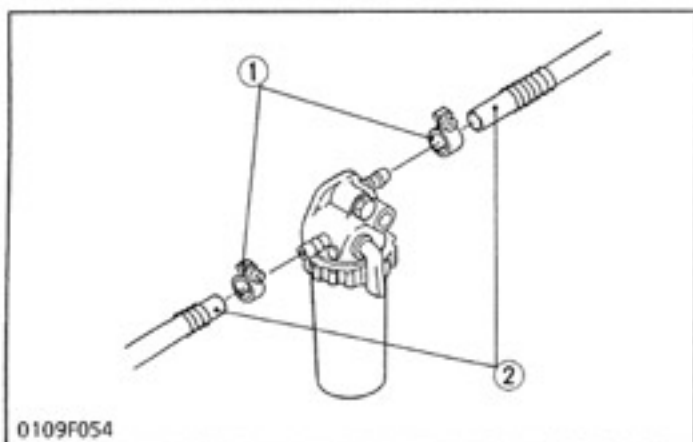
(2) Check Point of Every 50 hours**Checking Fuel Pipe**

1. If the clamp (1) is loose, apply oil to the threads and securely retighten it.
2. The fuel pipe (2) is made of rubber and ages regardless of the period of service.
Change the fuel pipe together with the clamp every two years.
3. However, if the fuel pipe and clamp are found to be damaged or deteriorate earlier than two years, then change or remedy.
4. After the fuel pipe and the clamp have been changed, bleed the fuel system.

⚠ CAUTION

- Stop the engine when attempting the check and change prescribed above.

- (1) Clamp
(2) Fuel Pipe

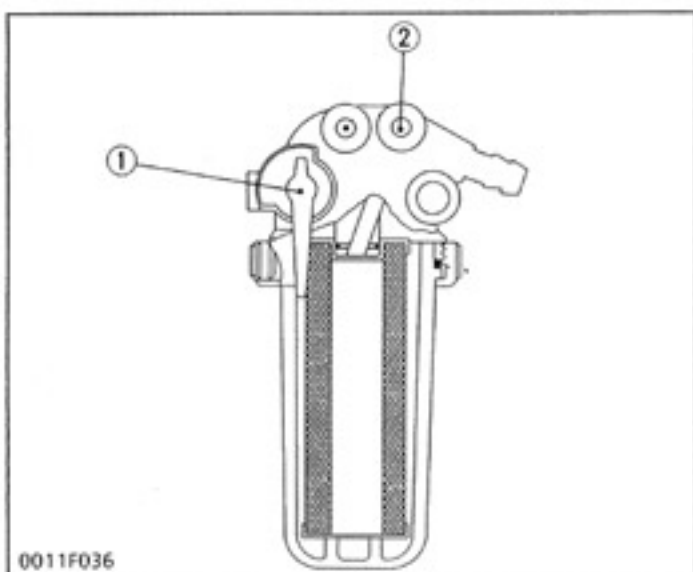
**(When bleeding fuel system)**

1. Fill the fuel tank with fuel, and open the fuel cock (1).
2. Loosen the air vent plug (2) of the fuel filter a few turns.
3. Screw back the plug when bubbles do not come up any more.
4. Open the air vent cock on top of the fuel injection pump.
5. Retighten the plug when bubbles do not come up any more.

■ NOTE

- Always keep the air vent plug on the fuel injection pump closed except when air is vented, or it may cause the engine to stop.

- (1) Fuel Cock
(2) Air Vent Plug

(3) Check Point of Every 100 hours**Changing Engine Oil**

1. After warming up, stop the engine.
2. To change the used oil, remove the drain plug at the bottom of the engine and drain off the oil completely.
3. Reinstall the drain plug.
4. Fill the new oil up to the upper notch on the dipstick.

■ IMPORTANT

- Engine oil should be MIL-L-46152/MIL-L-2104C or have properties of API classification CC/CD grades.
- Change the type of engine oil according to the ambient temperature.

Above 25°C (77°F)----- SAE 30 or 10W-30

0°C to 25°C (32°F to 77°F)----- SAE 20 or 10W-30

Below 0°C (32°F)----- SAE 10 W or 10W-30

Changing Engine Oil Filter Cartridge

1. Remove the oil filter cartridge with a filter wrench.
2. Apply engine oil to the rubber gasket on the new cartridge.
3. Screw the new cartridge in by hand.

■ NOTE

- Over-tightening may cause deformation of rubber gasket.
- After cartridge has been replaced, engine oil normally decreases a little. Check the oil level and add new oil to the specified level.

Checking Fan Belt Tension

1. Press the fan belt between fan pulley and pulley with your finger at force of 98N (10 kgf, 22 lbs). Check if the fan belt deflection is 7 to 9 mm (0.28 to 0.35 in.)
2. If the deflection is not within the factory specifications, adjust with the tension pulley adjusting bolts (1).

(1) Tension Pulley Adjusting Bolts

[A] Good

[B] Bad

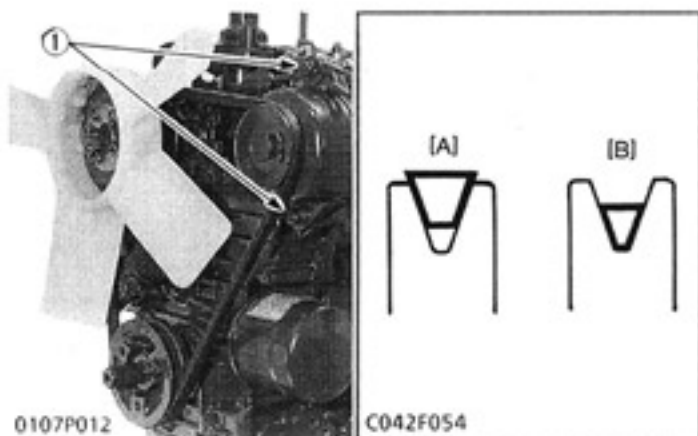

0107P012

C042F054

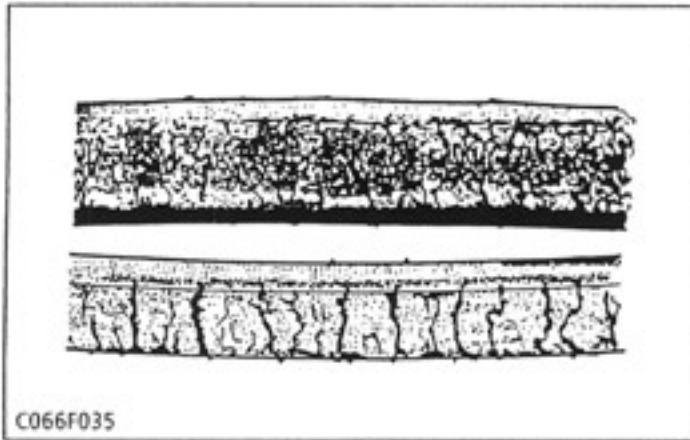

C066F035

Checking Fan Belt Damage

1. Check the fan belt for damage.
2. Check if the fan belt is worn and sunk in the pulley groove.
3. Replace the fan belt if the belt is damaged or nearly worn out and deeply sunk in the pulley groove.

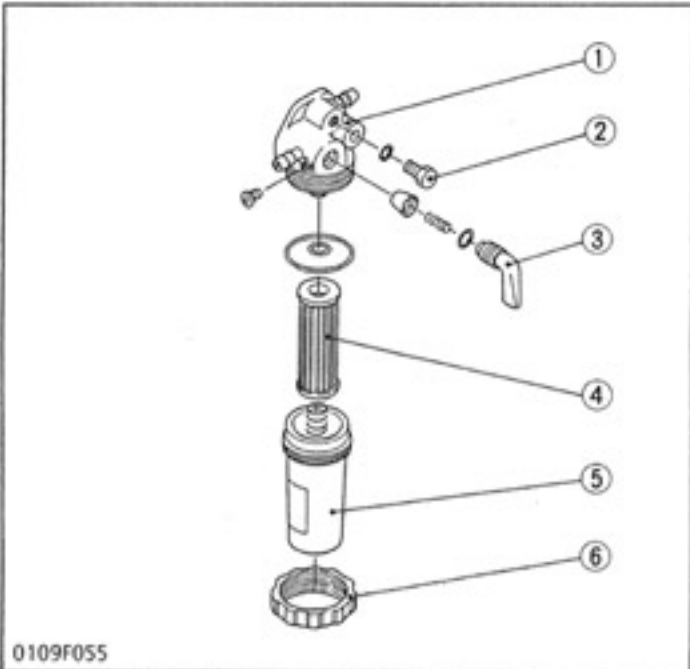

0109F055

Cleaning Fuel Filter

1. Close the fuel filter cock (3).
2. Unscrew the screw ring (6) and remove the cup (5), and rinse the inside with kerosene.
3. Take out the element (4) and dip it in the kerosene to rinse.
4. After cleaning, reassemble the fuel filter, keeping out dust and dirt.
5. Bleed the fuel system.

■ IMPORTANT

- If dust and dirt enter the fuel, the fuel injection pump and injection nozzle will wear quickly. To prevent this, be sure to clean the fuel filter cup periodically.

- (1) Cock Body
 (2) Air Vent Plug
 (3) Filter Cock
 (4) Filter Element
 (5) Filter Cup
 (6) Screw Ring

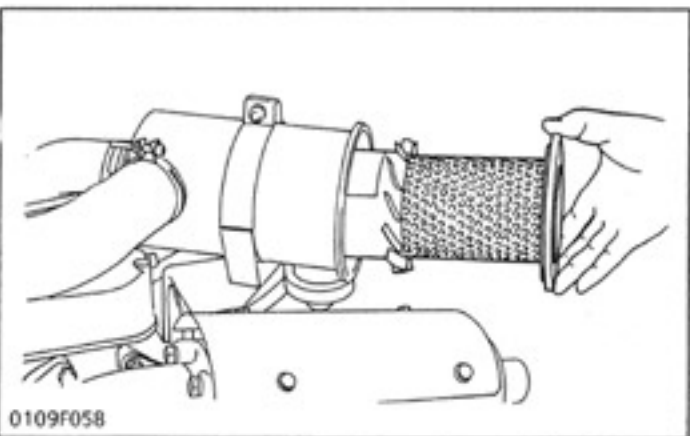

0109F058

Cleaning Air Cleaner

1. The air cleaner uses a dry element. Never apply oil to it.
2. Remove and clean out the dust cup before it becomes half full with dust.
3. When the air filter element is dusty, clean it.

■ NOTE

- Change the element once a year or every 6th cleaning.

■ IMPORTANT

- Install the air cleaner dust cup with "TOP" indicated on the rear of the cup in the upside. If the dust cup is mounted incorrectly, dust or dirt does not collect in the cup, and direct attachment of the dust to the element will cause its life time to shorten to a great extent.



Cleaning Air Filter Element

- **When dry dust adheres**
Use clean dry compressed air on the inside of the element.
Air pressure at the nozzle must not exceed 690 kPa (7 kgf/cm², 100 psi).
Maintain reasonable distance between the nozzle and the filter.

(4) Check Point of Every 800 hours

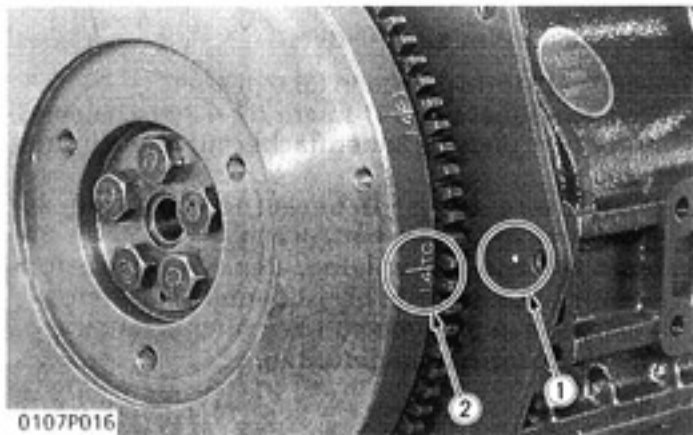

Checking Valve Clearance

■ IMPORTANT

- Valve clearance must be checked and adjusted when engine is cold.
1. Remove the head cover.
 2. Measure the clearance with a feeler gauge after aligning each cylinder with the top dead center of compression.
 3. If the clearance is not within the factory specifications, adjust with the adjusting screw.

■ NOTE

- After turning the flywheel counterclockwise twice or three times, recheck the valve clearance.
- After adjusting the valve clearance, firmly tighten the lock nut of the adjusting screw.

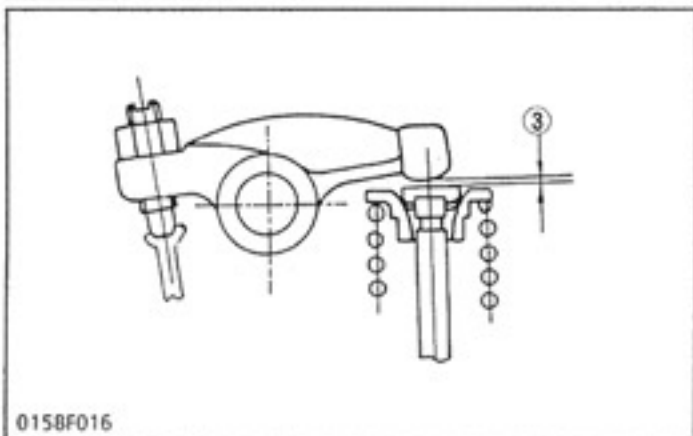

- (1) Notched Portion
- (2) TC Mark Line
- (3) Valve Clearance

(5) Check Points of 1000 hours**⚠ CAUTION**

- Check the nozzle injection pressure and condition after confirming that there is nobody standing in the direction the fume goes. If the fume from the nozzle directly contacts the human body, cells may be destroyed and blood poisoning may be caused.

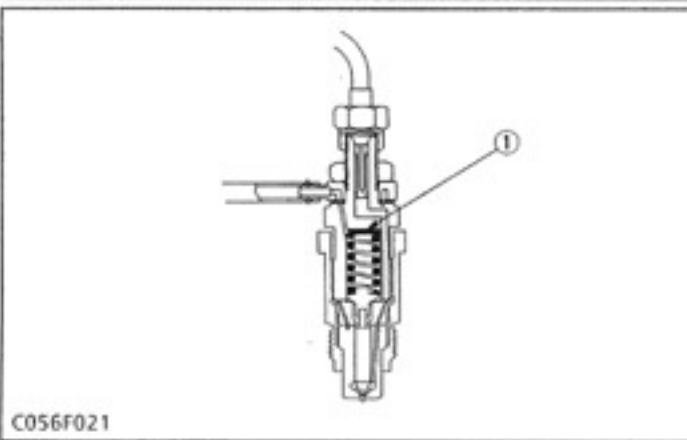
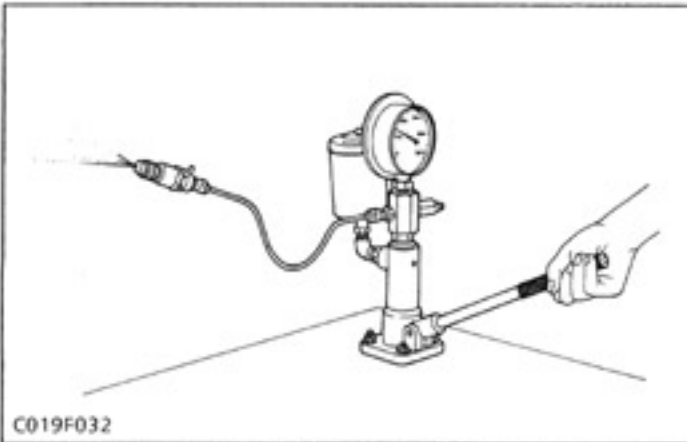
**Checking Nozzle Injection Pressure**

1. Set the injection nozzle to the nozzle tester (Code No: 07909-31361).
2. Slowly move the tester handle to measure the pressure at which fuel begins jetting out from the nozzle.
3. If the measurement is not within the factory specifications, disassemble the injection nozzle, and change adjusting washer (1) until the proper injection pressure is obtained. (See page S-117)
4. If the spraying condition is defective, replace the nozzle piece.

(Reference)

- Pressure variation with 0.1 mm (0.0039 in.) difference of adjusting washer thickness.
Approx. 981 kPa (10 kgf/cm², 142 psi)

(1) Adjusting Washer

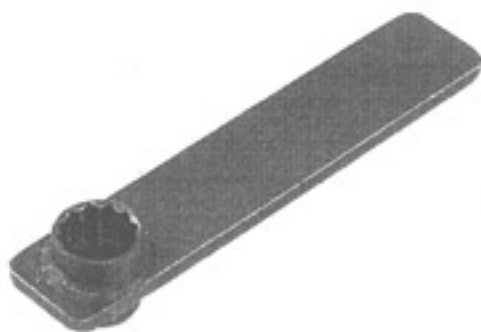
🔧 SPECIAL TOOLS

0107F047

Socket Wrench 29

Code No: 07916-31841

Application: Use to take off and to fix the crankshaft nut of diesel engine.

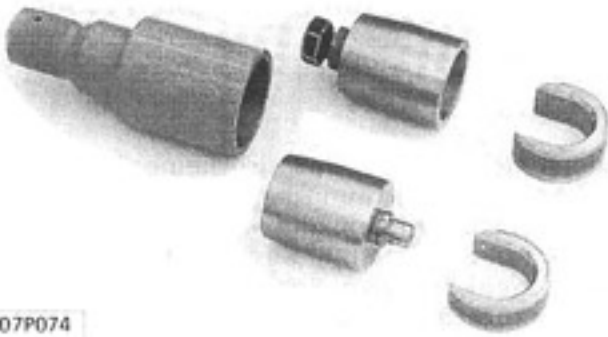

0107P074

Auxiliary Socket For Fixing Crankshaft Sleeve

Code No: 07916-33011

Application: Use to fix the crankshaft sleeve of the diesel engine.

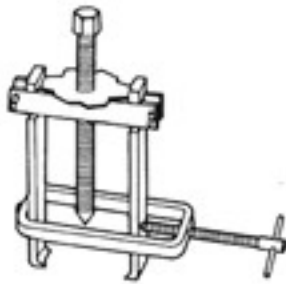

ST10F003

Special-use Puller Set

Code No: 07916-09032

Application: Use for pulling out bearings, gears and other parts.



ST10F002

Dry Liner Changer-II

Code No: 07916-33081

Application: A puller for pulling out the dry liner. It combines with a presser for pushing in the dry liner.



ST10F009

Valve Seat Cutter Set

Code No: 07909-33102

Application: Use for correcting valve seats.

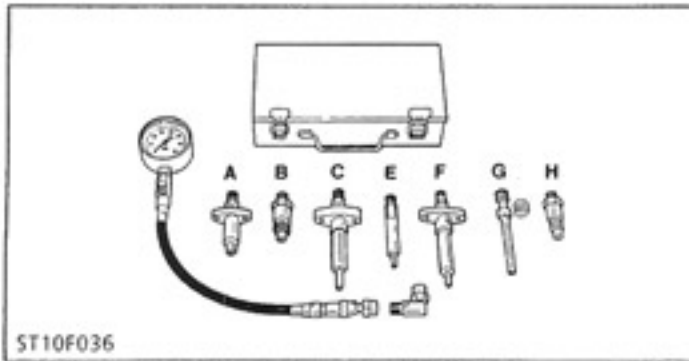

ST10F036

Diesel Engine Compression Tester

Code No: 07909-30206

Application: Use for measuring diesel engine compression pressure.

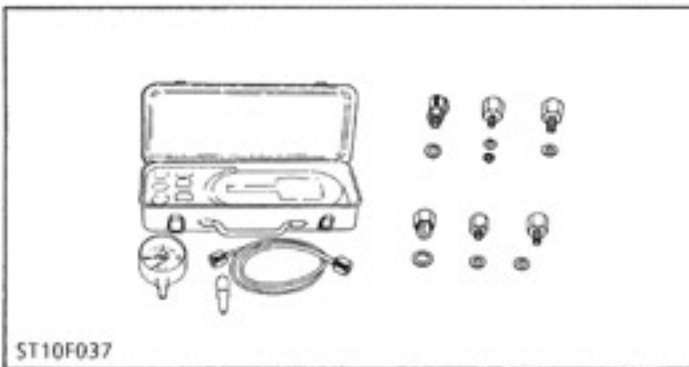

ST10F037

Oil Pressure Tester

Code No: 07916-32031

Application: Use for measuring lubricating oil pressure.

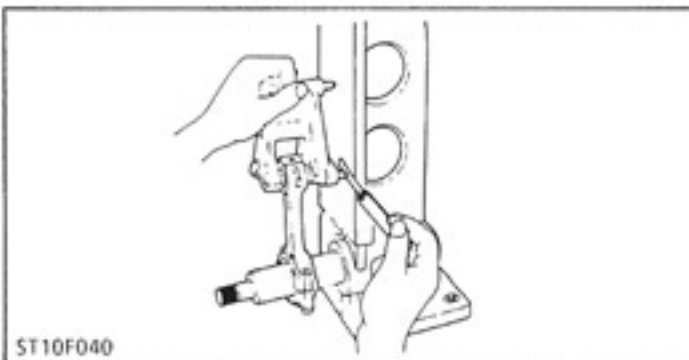

ST10F040

Connecting Rod Alignment Tool

Code No: 07909-31661

Application: Use for checking the connecting rod alignment.

Applicable: Connecting rod big end I.D. 30 to 75 mm (1.18 to 2.95 in. dia.) Connecting rod length 65 to 330 mm (2.56 to 12.99 in.)

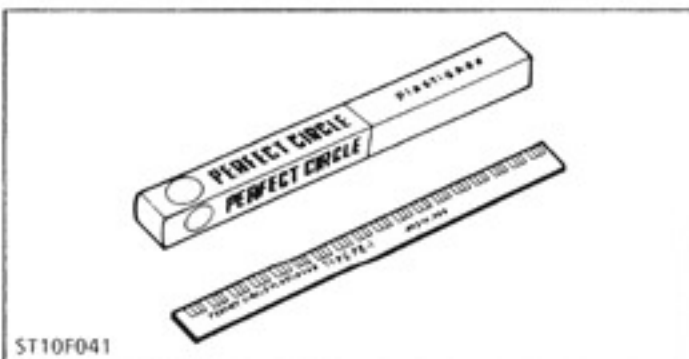

ST10F041

Press Gauge

Code No: 07909-30241

Application: Use for checking the oil clearance between crankshaft and bearing, etc.

Measuring range: Green — 0.025 to 0.076 mm (0.001 to 0.003 in.)

Red — 0.051 to 0.152 mm (0.002 to 0.006 in.)

Blue — 0.102 to 0.229 mm (0.004 to 0.009 in.)

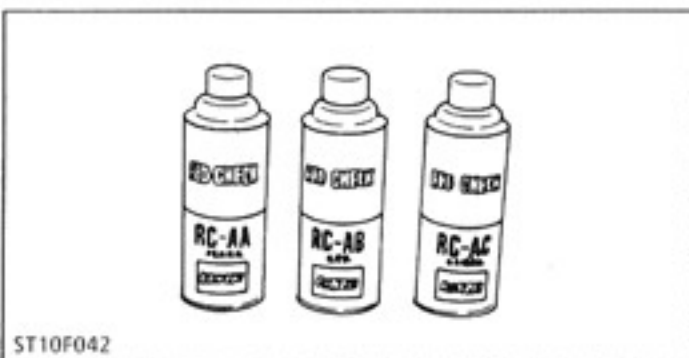

ST10F042

Red Check (Crack check liquid)

Code No: 07909-31371

Application: Use for checking cracks on cylinder head, cylinder block, etc.

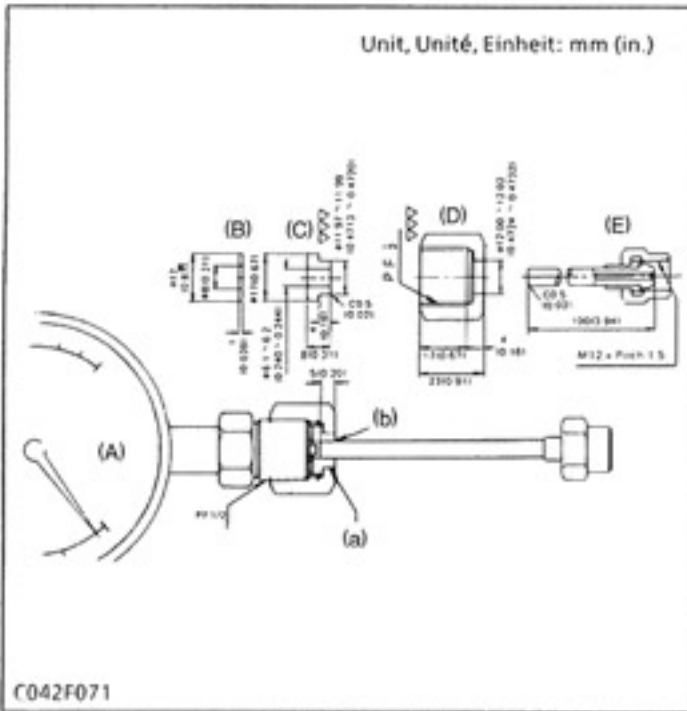

NOTE

- The following special tools are not provided, so make them referring to the figures.

Injection Pump Pressure Tester

Application: Use for checking fuel tightness of the injection pump.

| | |
|---|--|
| A | Pressure gauge Full scale: More than 29.4 MPa (300 kgf/cm ² , 4267 psi) |
| B | Copper gasket |
| C | Flange (Material: Steel) |
| D | Hex. nut 27 mm (1.06 in.) across the flat (Material: Steel) |
| E | Injection Pipe |

- (a) Adhesive application
- (b) Fillet welding on the inner circumference

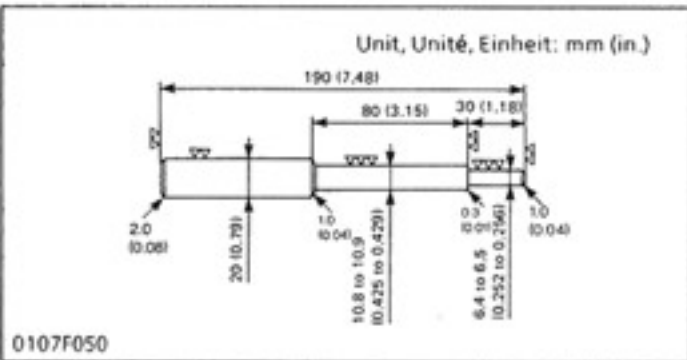

Valve Guide Replacing Tool

Application: Use to press out and to press fit the valve guide.

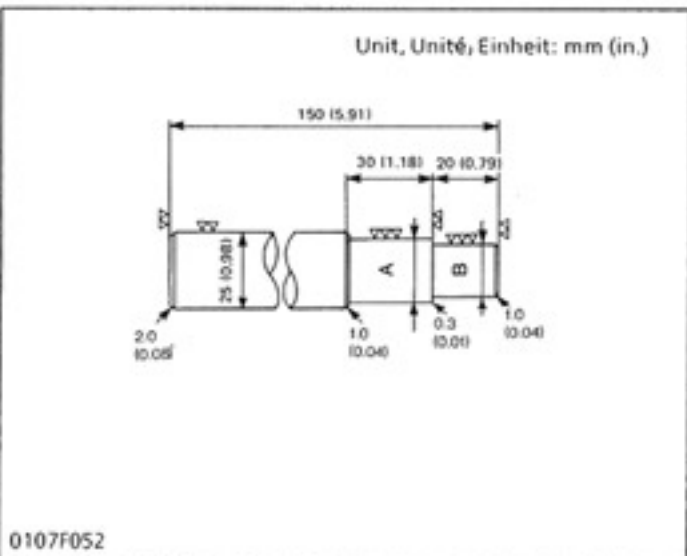

Idle gear Bushing Replacing Tool

Application: Use to press out and to press fit the idle gear bushing.

| Bushing I.D. | A | B |
|---------------------|---|---|
| 18 mm 0.7087 in. | 19.90 to 19.95 mm 0.7835 to 0.7854 in. | 17.90 to 17.95 mm 0.7047 to 0.7067 in. |
| 24 mm 0.9449 in. | 25.90 to 25.95 mm 1.0197 to 1.0217 in. | 23.90 to 23.95 mm 0.9409 to 0.9429 in. |
| 30 mm 1.1811 in. | 31.90 to 31.95 mm 1.2559 to 1.2579 in. | 29.90 to 29.95 mm 1.1772 to 1.1791 in. |

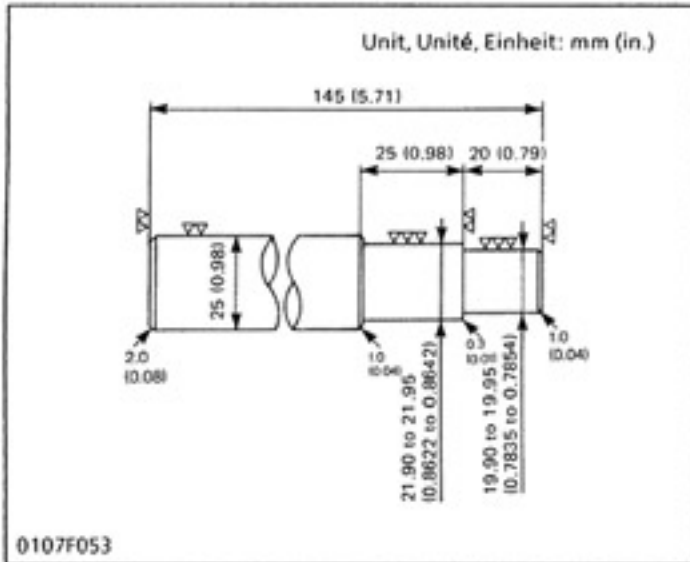

Small End Bushing Replacing Tool

Application: Use to press out and to press fit the small end bushing.

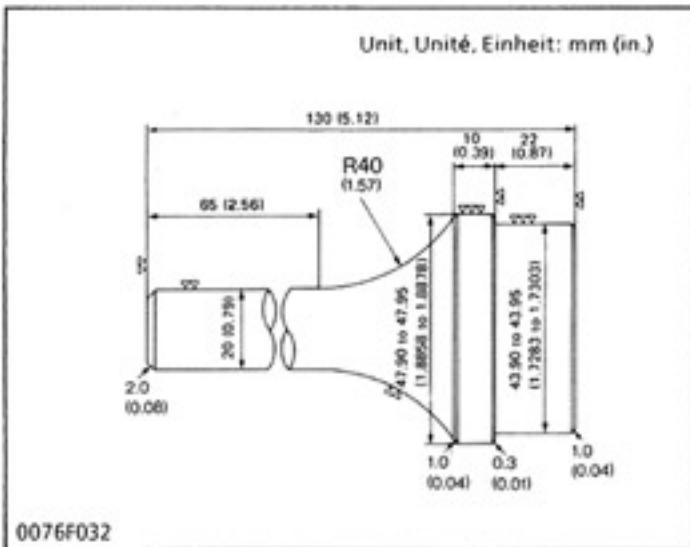

Crankshaft Bearing 1 Replacing Tool

Application: Use to press out and to press fit the crankshaft bearing 1.

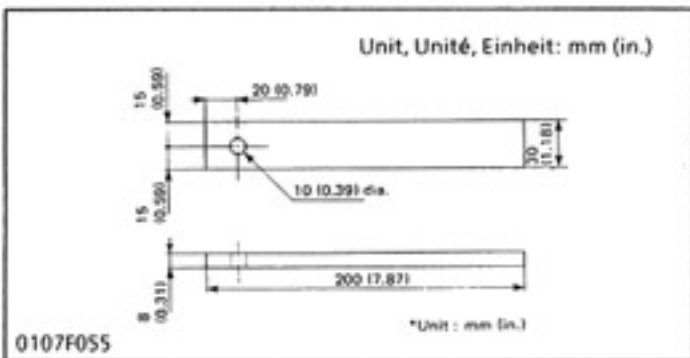

Flywheel Stopper

Application: Use to loosen and tighten the flywheel screw.

1 ENGINE BODY

CHECKING AND ADJUSTING

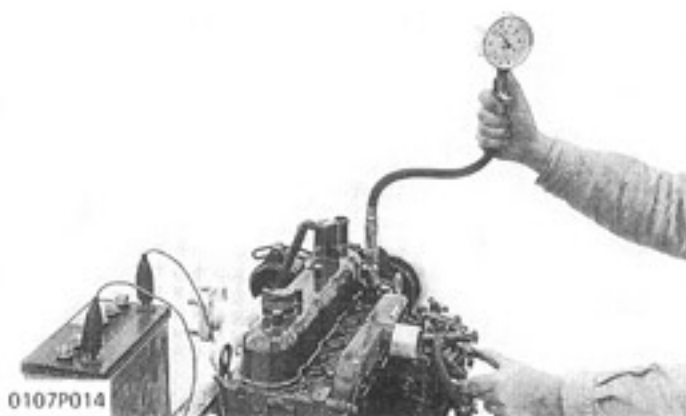

Compression Pressure

1. After warming up the engine, stop it and remove the air cleaner, the muffler and all nozzle holders.
2. Install a compression tester (Code No: 07909-30204) for diesel engines to nozzle holder hole.
3. After making sure that the speed control lever is set at the stop position (Non-injection), run the engine at 200 to 300 r.p.m. with the starter.
4. Read the maximum pressure. Measure the pressure more than twice.
5. If the measurement is below the allowable limit, check the cylinder, piston ring, top clearance, valve and cylinder head.

NOTE

- Variances in cylinder compression values should be under 10%.

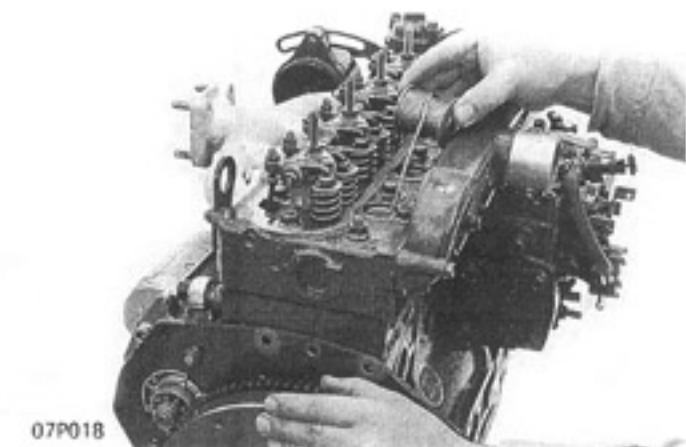

Top Clearance

1. Remove the nozzle holder.
2. Lower the piston in the cylinder.
3. Insert a high quality fuse from the nozzle holder hole on the piston except where it faces the valve or the combustion chamber insert.
4. Rotate the flywheel until the piston is raised and lowered again.
5. Take out the fuse carefully.
6. Repeat three times with a new fuse in the other directions.
7. Measure the thickness of the crushed fuse with vernier calipers.
8. If the measurement is not within the factory specifications, check the oil clearance of the crank pin and clearance between the piston pin and bushing.

(Reference)

- Top clearance (A) can also be got by measuring the projection (C) of the piston from the liner flange, and calculate.

$$\text{Top clearance (A)} = \text{Head Gasket Thickness (B)} - \text{Piston Projection (C)}$$

| | |
|--|---|
| Head gasket thickness (B) (after retightened) | 1.05 to 1.15 mm 0.0413 to 0.0453 in. |
| Projection (C) | 0.25 to 0.55 mm 0.010 to 0.022 in. |

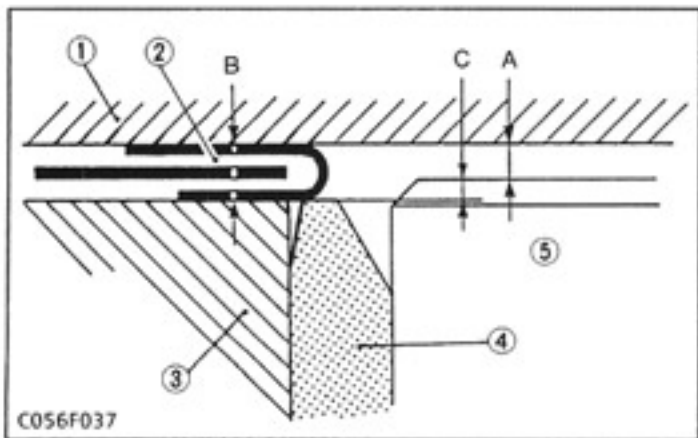

- | | |
|--------------------|--------------------|
| (1) Cylinder Head | (4) Cylinder Liner |
| (2) Head Gasket | (5) Piston |
| (3) Cylinder Block | |

DISASSEMBLING AND ASSEMBLING

[1] DRAINING WATER AND OIL

Draining Cooling Water and Engine Oil

CAUTION

- Never remove radiator cap until cooling water temperature is below its boiling point. Then loosen cap slightly to the stop to relieve any excess pressure before removing cap completely.
1. Prepare a bucket. Open the drain cock to drain cooling water.
 2. Prepare an oil pan. Remove the drain plug to drain engine oil in the pan.

[2] EXTERNAL COMPONENTS

Air Cleaner and Muffler

1. Remove the air cleaner.
2. Remove muffler retaining nuts to remove the muffler.

(When reassembling)

- Install the muffler gasket so that its steel side face the muffler.

[3] CYLINDER HEAD AND VALVES

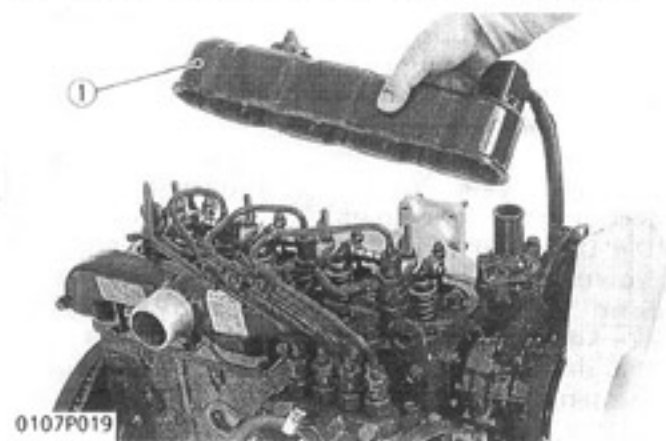

Cylinder Head Cover

1. Remove the cylinder head cover cap nuts.
2. Remove the cylinder head cover (1).

(When reassembling)

- Check to see that the cylinder head cover gasket is not defective.

(1) Head Cover

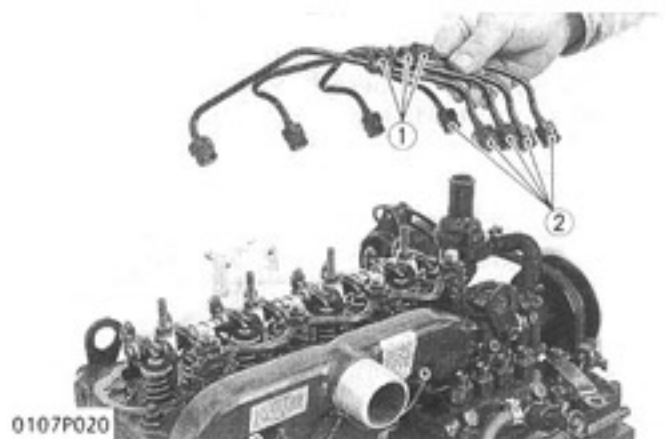

Injection Pipe

1. Loosen the pipe clamps (1).
2. Remove the injection pipes (2).

(1) Pipe Clamps
(2) Injection Pipes

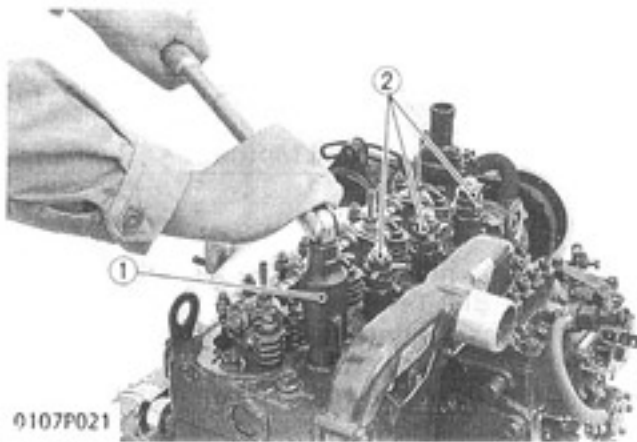

Nozzle Holder Assembly

1. Remove the fuel overflow pipes.
2. Loosen the lock nuts, and remove the nozzle holder assemblies with a nozzle holder socket wrench 27 (1).
3. Remove the copper gaskets on the seats.

- (1) Nozzle Holder Socket Wrench
(2) Nozzle Holder Assembly

0107P021

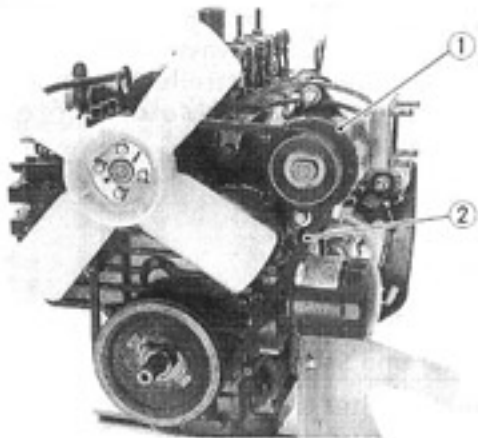

Alternator and Fan Belt

1. Remove the alternator (1).
2. Remove the fan belt (2).

(When reassembling)

- Check to see that there are no cracks on the belt surface.

■ IMPORTANT

- After reassembling the fan belt, be sure to adjust the fan belt tension.

- (1) Alternator
(2) Fan Belt

0076P013

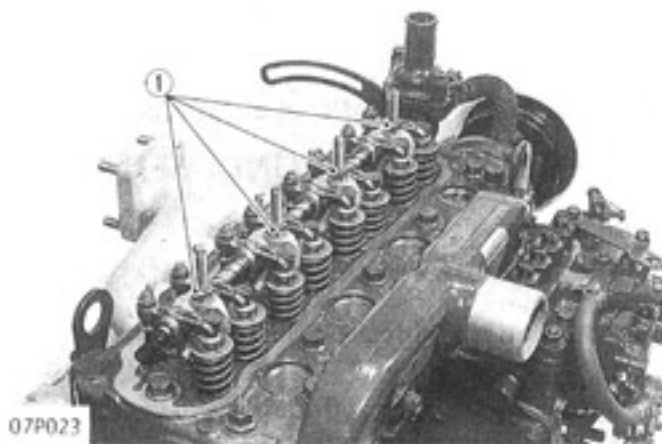

Rocker Arm

1. Remove the rocker arm bracket mounting nuts (1).
2. Remove the rocker arm as a unit.

■ IMPORTANT

- After reassembling the rocker arm, be sure to adjust the valve clearance.

- (1) Rocker Arm Bracket Mounting Nuts

07P023

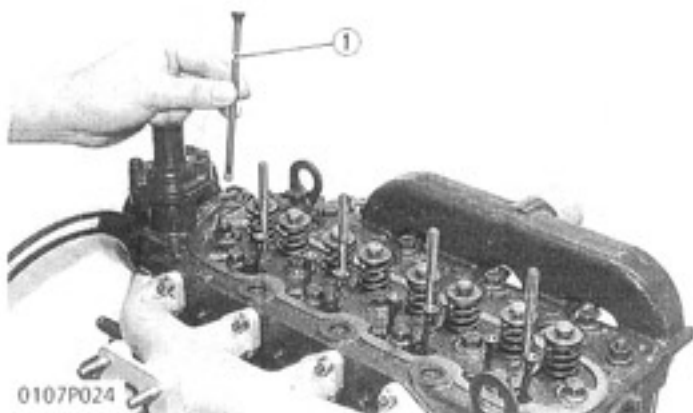

Push Rod

1. Remove the push rods.

(When reassembling)

- When putting the push rods onto the tappets, check to see if their ends are properly engaged with the grooves.

- (1) Push Rod

0107P024

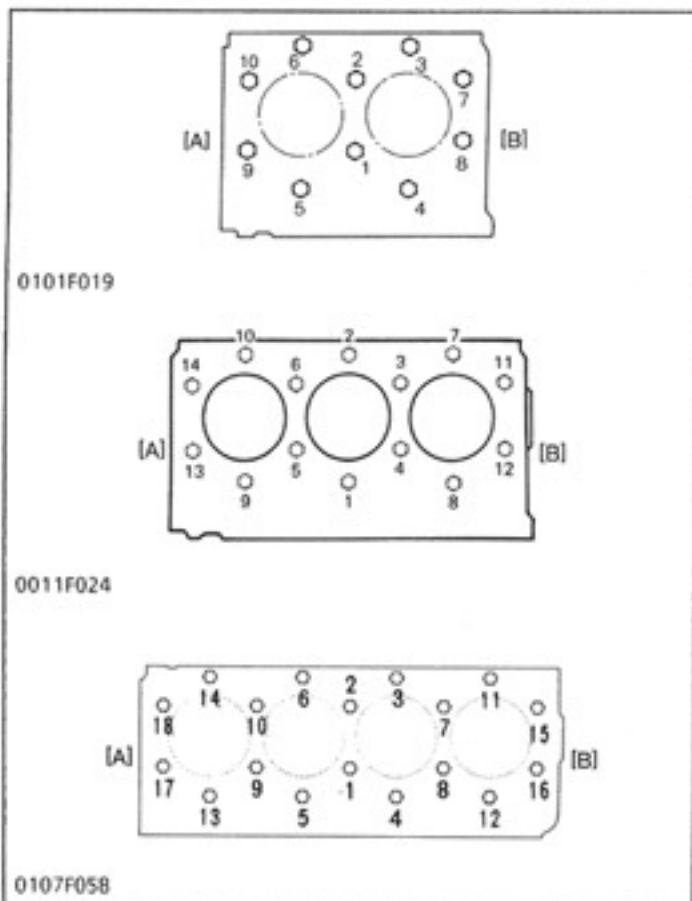

Cylinder Head

1. Loosen the pipe band, and remove the water return pipe.
2. Remove the cylinder head screws and nuts in the order of (10, 14, 18) to (1), and remove the cylinder head.
3. Remove the cylinder head gasket and O-ring.

(When reassembling)

- Replace the head gasket with a new one.
- Install the cylinder head, using care not to damage the O-ring.
- Tighten the cylinder head screws and nuts gradually in the order of (1) to (10, 14, 18) after applying engine oil.
- Retighten the cylinder head screws and nuts after running the engine for 30 minutes.

[A] Gear case side

[B] Flywheel side

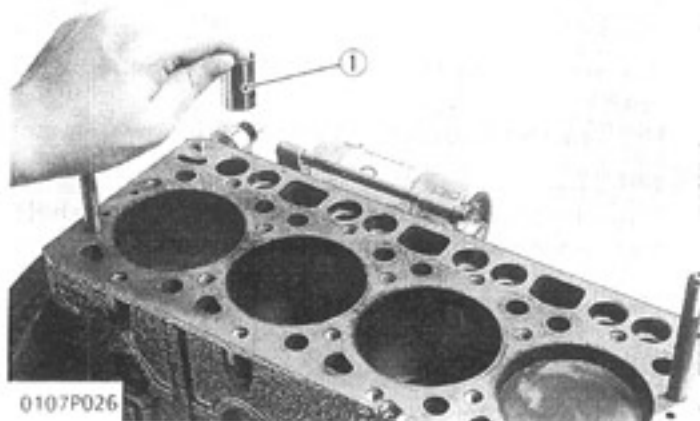

Tappets

1. Remove the tappets from the crankcase.

(When reassembling)

- Before installing the tappets, apply engine oil thinly around them.

■ NOTE

- Mark the cylinder number to the tappets to prevent interchanging.

(1) Tappet

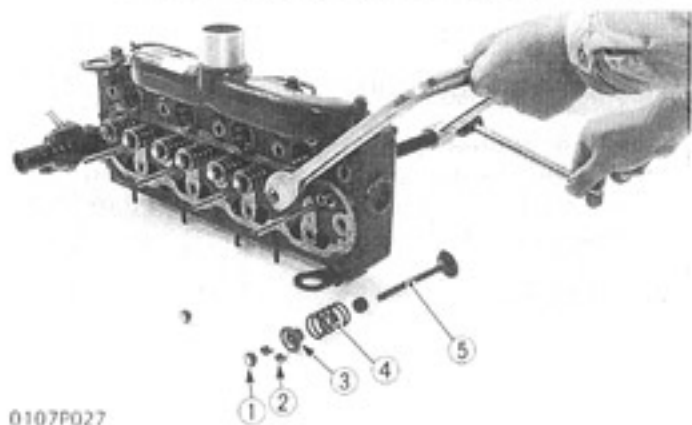

Valves

1. Remove the valve cap (1).
2. Remove the valve spring collet (2) with a valve lifter.
3. Remove the valve spring retainers (3), valve spring (4) and valve (5).

(When reassembling)

- Wash the valve stem and valve guide hole, and apply engine oil sufficiently.
- After installing the valve spring collets, lightly tap the stem to assure proper fit with a plastic hammer.

(1) Valve Cap

(2) Valve Spring Collet

(3) Valve Spring Retainer

(4) Valve Spring

(5) Valve

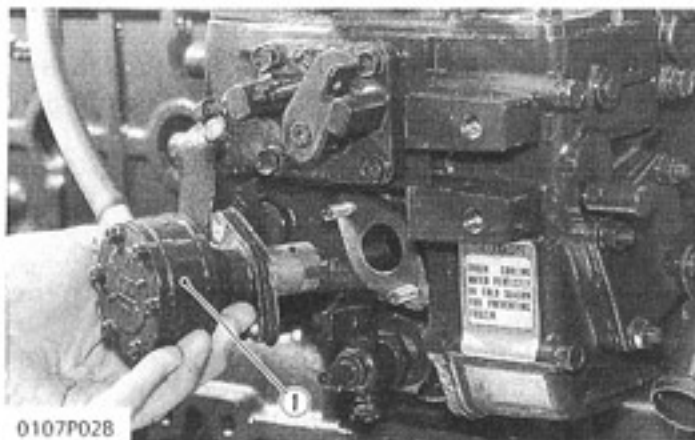
[4] GEAR CASE

0107P028

Fuel Feed Pump

1. Loosen the pipe clamp and remove the fuel pipe from the injection pump side.
2. Remove the fuel feed pump mounting nuts.
3. Remove the fuel feed pump (1).

(When reassembling)

- Apply a liquid gasket (Three Bond 1215 or equivalent) to the both sides of fuel feed pump gasket.

(1) Fuel Feed Pump

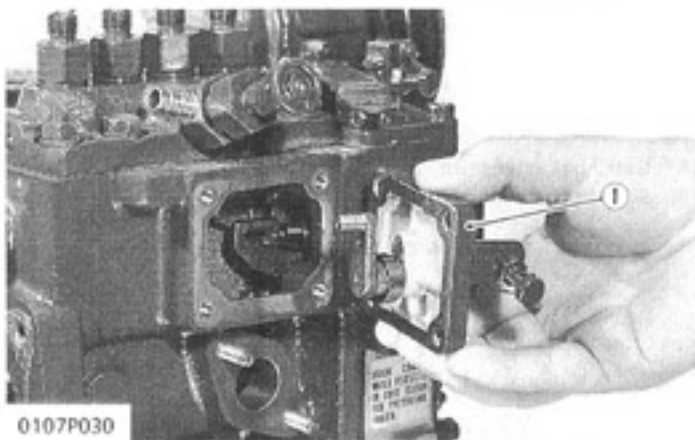

0107P030

Injection Pump Cover

1. Remove the injection pump cover (1).

(When reassembling)

- Apply a liquid gasket (Three Bond 1215 or equivalent) to the both sides of injection pump cover gasket.

(1) Injection Pump Cover

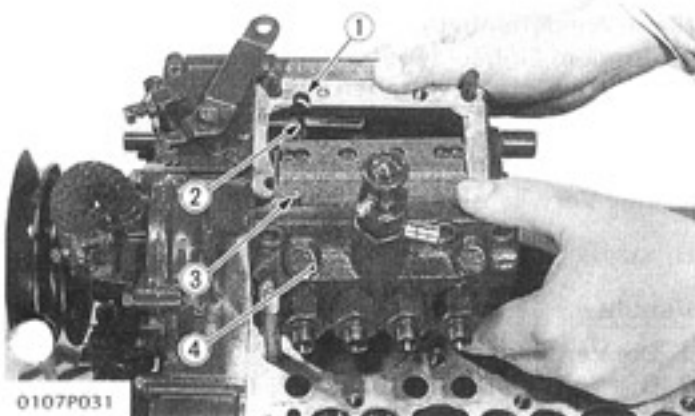

0107P031

Injection Pump

1. Remove the injection pump mounting screws and nuts.
2. Align the control rack pin (3) with the notch (1) on the crankcase, and remove the injection pump (4).
3. Remove the injection pump shims.
4. In principle, the injection pump should not be disassembled.

(When reassembling)

- When installing the injection pump, insert the control rack pin (3) firmly into the groove (2) of the fork lever 1.
- Addition or reduction of one shim delays or advances the injection timing by 1.5° (0.026 rad).

■ IMPORTANT

- Insert the same number of shims as used before between crank case and pump, and then check the injection timing.
- Apply a thin coat of liquid gasket (Three Bond 1215 or equivalent) to the shims.

(1) Notch

(2) Groove

(3) Control Rack Pin

(4) Injection Pump

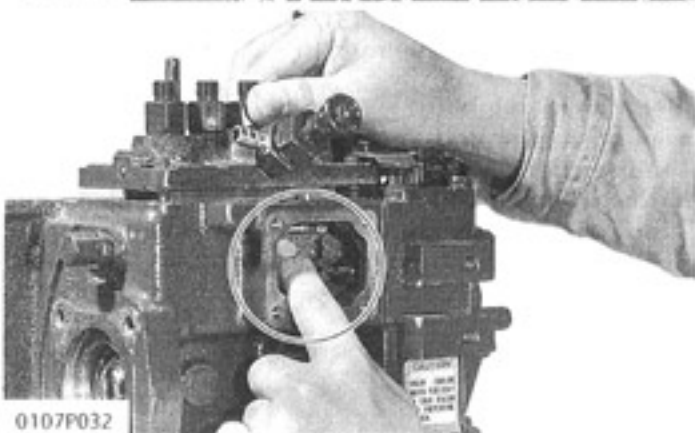

0107P032

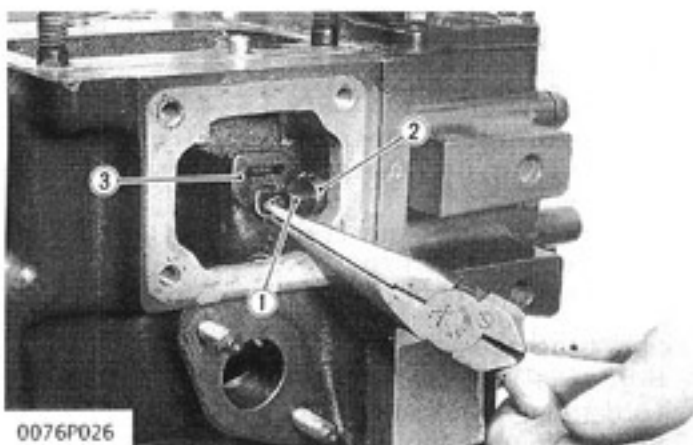

0076P026

Governor Spring

1. Remove the governor springs 1 (2) and 2 (1) from the fork lever 2 (3).

(When reassembling)

- Fix the governor springs 1 and 2 to the governor lever, and pull the springs through the window of the injection pump, and springs will be able to be hooked on to the governor fork lever 2 with ease.

- (1) Governor Spring 2
- (2) Governor Spring 1
- (3) Fork Lever 2

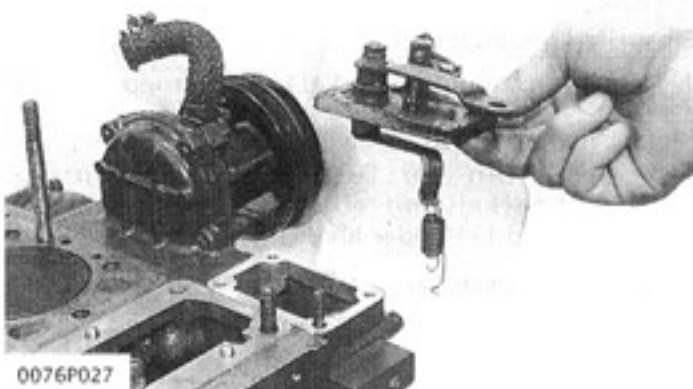

0076P027

Speed Control Plate

1. Remove the speed control plate with the governor springs 1 and 2.

(When reassembling)

- Be careful not to drop the governor springs 1 and 2 into the gear case.
- Apply a liquid gasket (Three Bond 1215 or equivalent) to both sides of the speed control plate gasket.

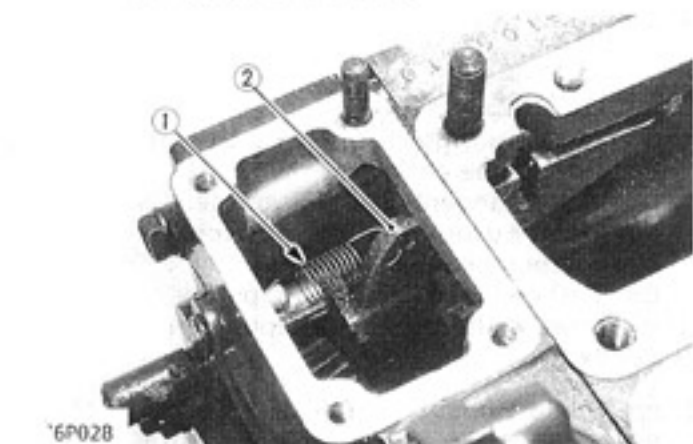

0076P028

Start Spring

1. Remove the start spring (1) from the fork lever 1 (2).

(When reassembling)

- Be careful not to drop the start spring into the gear case.

- (1) Start Spring
- (2) Fork Lever 1

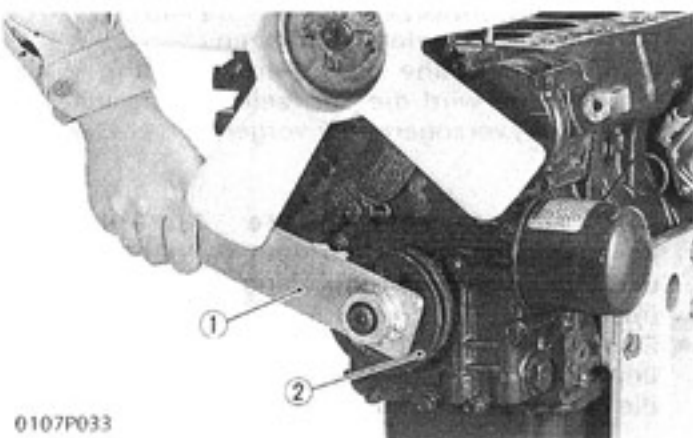

0107P033

Fan Drive Pulley

1. Flatten the crankshaft washer and remove the crankshaft nut with a socket wrench 29 (1) (Code No: 07916-31841).
2. Pull out the fan drive pulley (2) with a puller.
3. Remove the feather key.

(When reassembling)

- Replace the crankshaft washer with a new one.
- After tightening the crankshaft nut to the specified torque, lock the nut with the crankshaft washer.

- (1) Socket Wrench 29
- (2) Fan Drive Pulley

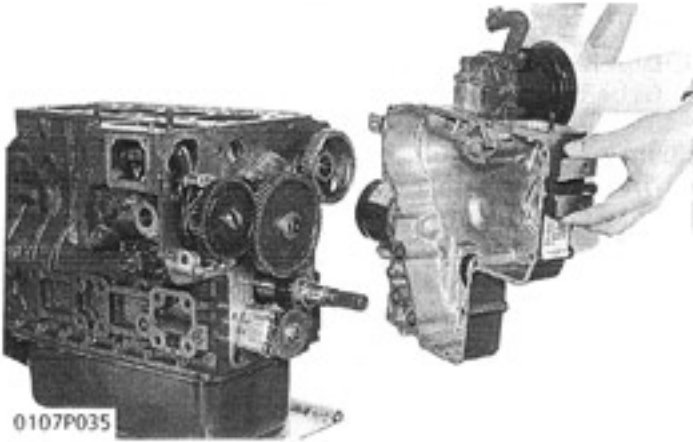

Gear Case

1. Remove the gear case.

(When reassembling)

- Apply a liquid gasket (Three Bond 1215 or equivalent) to both sides of the gear case gasket.
- Grease thinly to the oil seal, and install it, ensuring the lip does not come off.

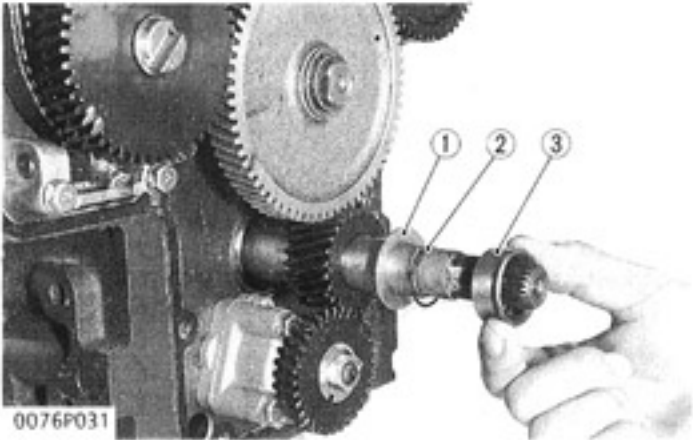

Crankshaft Oil Slinger

1. Remove the crankshaft collar (3).
2. Remove the O-ring (2).
3. Remove the crankshaft oil slinger (1).

- (1) Crankshaft Oil Slinger
(2) O-ring
(3) Crankshaft Collar

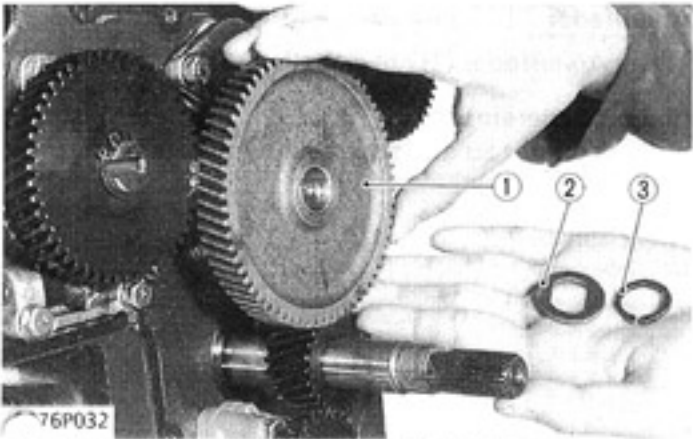

Idle Gear

1. Remove the external snap ring (3).
2. Remove the idle collar 2 (2) and idle gear (1).
3. Remove the idle gear collar 1.

■ IMPORTANT

- When installing the idle gear, be sure to align the alignment marks on gears.
Idle gear and crank gear (Alignment mark •)
Idle gear and camshaft gear (Alignment mark ••)
Idle gear and injection pump gear (Alignment mark •••)

- (1) Idle Gear
(2) Idle Collar 2
(3) External Snap Ring

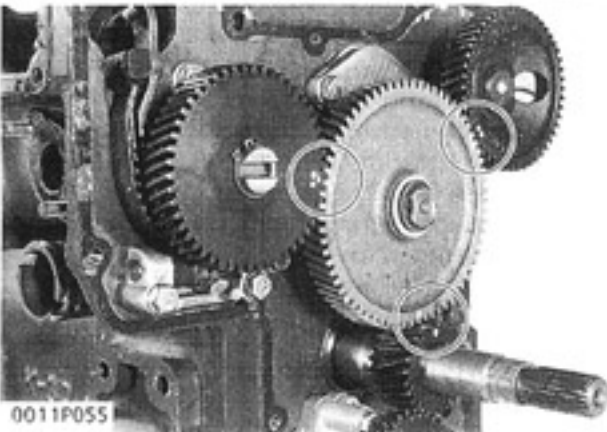

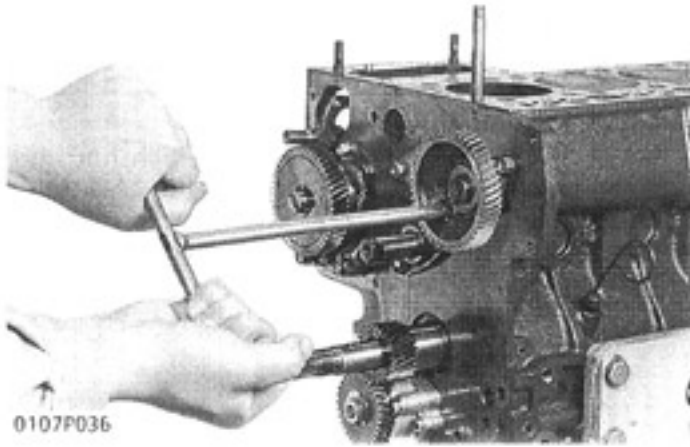

0107P036

Camshaft Stopper Mounting Screw

1. Align the round hole on the cam gear with the camshaft stopper mounting screw position.
2. Remove the camshaft stopper mounting screws.

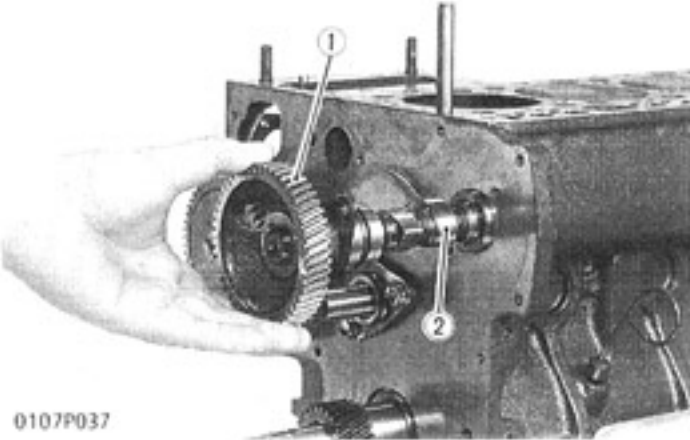

0107P037

Cam Gear and Camshaft

1. Remove the cam gear (1) and camshaft (2).

(When reassembling)

- Apply engine oil thinly to the camshaft before installation.

(1) Cam Gear

(2) Camshaft

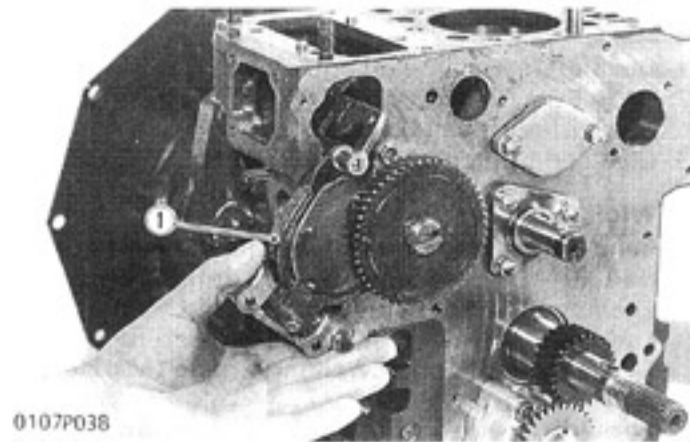

0107P038

Fork Lever Assembly

1. Remove the fork lever holder mounting screws.
2. Remove the fork lever assembly (1).

(1) Fork Lever Assembly

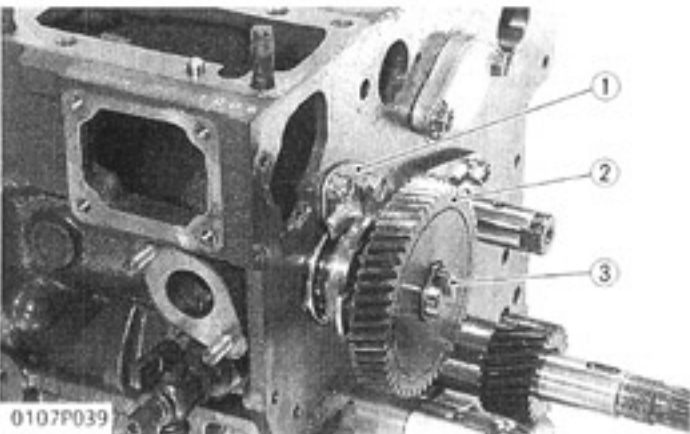

0107P039

Fuel Camshaft

1. Remove the fuel camshaft stopper (1).
2. Remove the fuel camshaft (3) and injection pump gear (2).

(When reassembling)

- Apply engine oil thinly to the fuel camshaft before installation.

(1) Fuel Camshaft Stopper

(2) Injection Pump Gear

(3) Fuel Camshaft

[5] PISTON AND CONNECTING ROD

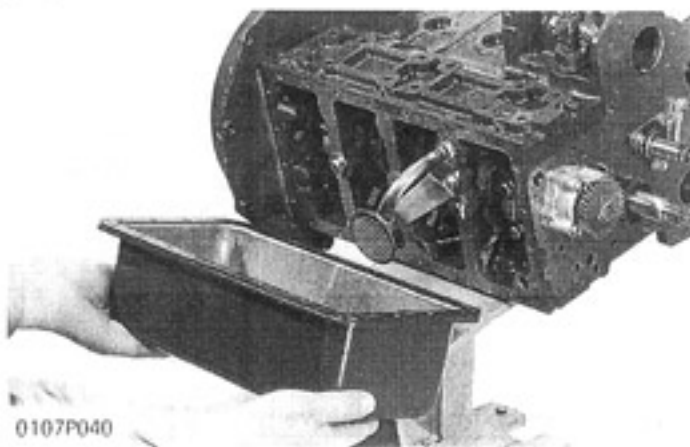

0107P040

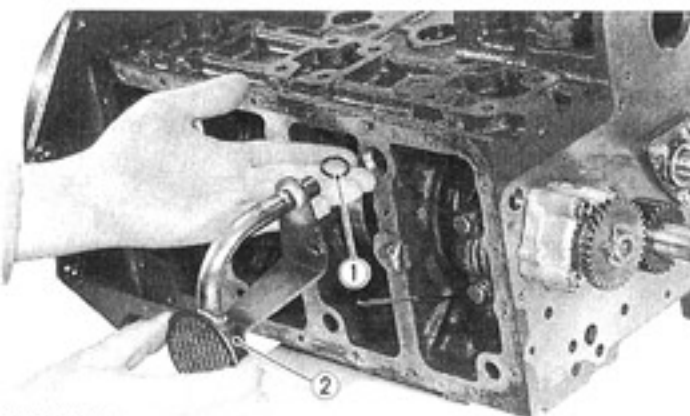

0107P041

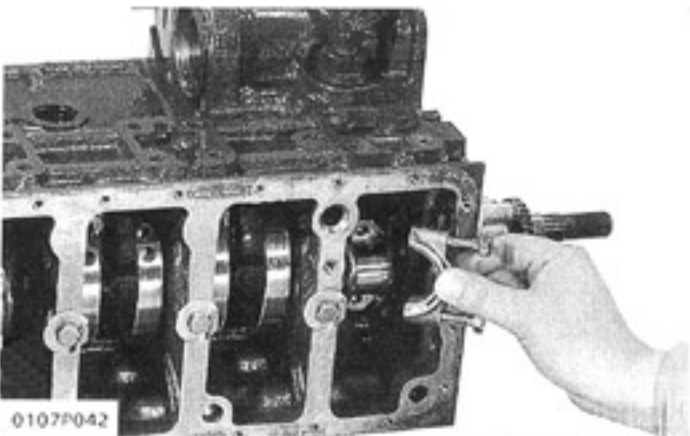

0107P042

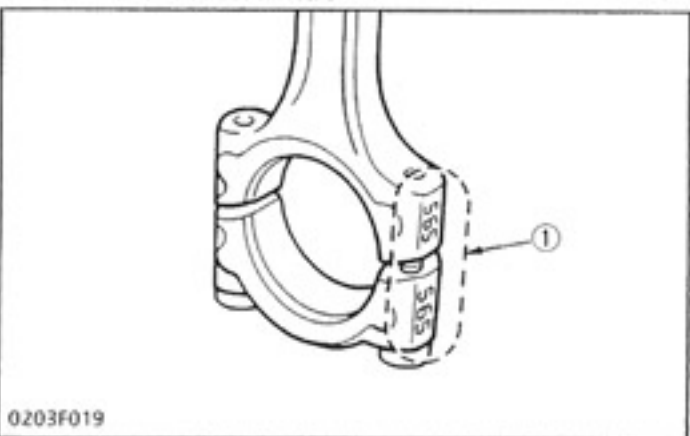

0203F019

Oil Pan

1. Remove the oil pan mounting screws.
2. Remove the oil pan by lightly tapping the rim of the oil pan with a wooden hammer.

(When reassembling)

- Apply a liquid gasket (Three Bond 1215 or equivalent) to both sides of the oil pan gasket.
- To avoid uneven tightening, tighten mounting screws in diagonal order from the center.

Oil Strainer

1. Remove the oil strainer mounting screw.
2. Remove the oil strainer (2).

(When reassembling)

- After cleaning the oil strainer, install it. Install the oil strainer, using care not to damage the O-ring (1).

- (1) O-ring
(2) Oil Strainer

Connecting Rod Cap

1. Remove the connecting rod screws from connecting rod cap.
2. Remove the connecting rod caps.

(When reassembling)

- Apply engine oil to the crank pin bearings.
- Apply engine oil to the connecting rod screws.
- Align the marks (1) on the connecting rod and connecting rod cap.

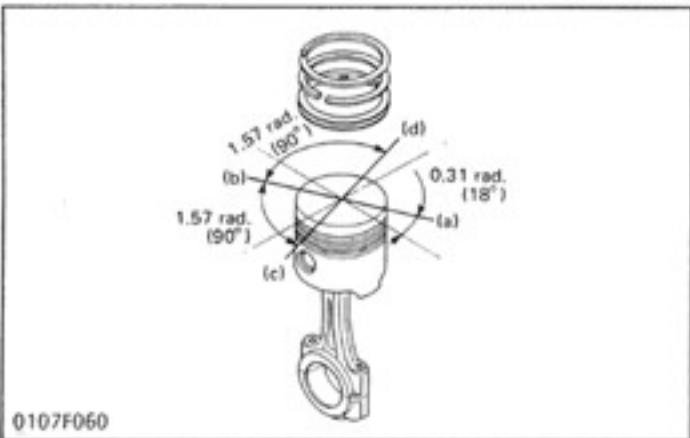
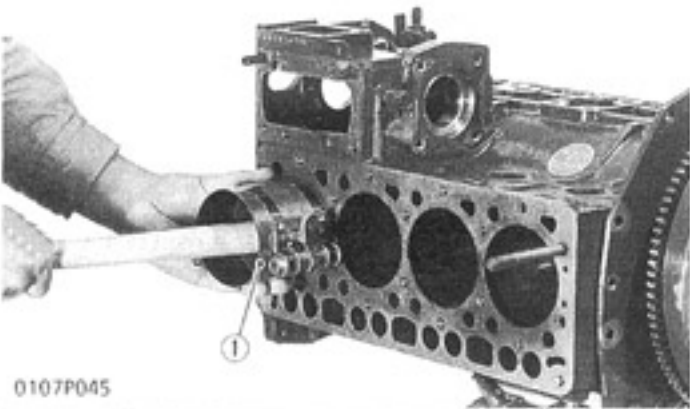
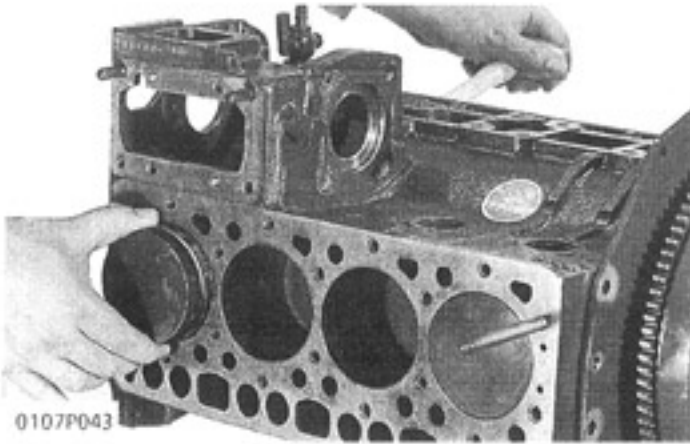

Piston

1. Turn the flywheel, and bring the No.1 piston to the top dead center.
2. Pull out the piston upward by lightly tapping it from the bottom of the crankcase with the grip of a hammer.

(When reassembling)

- Before inserting the piston into the cylinder, apply enough engine oil to the cylinder.
- When inserting the piston into the cylinder, face the mark on the connecting rod to the injection pump.

■ IMPORTANT

- Do not change the combination of cylinder and piston. Make sure of the position of each piston by marking. For example, mark "1" on the No.1 piston.
- When inserting the piston into the cylinder, place the gap of the compression ring 1 on the opposite side of the combustion chamber and stagger the gaps of the compression ring 2 and oil ring making a right angle from the gap of the compression ring 1.
- Carefully insert the pistons using a piston ring compressor (1). Otherwise, their chrome-plated section may be scratched, causing trouble inside the liner.

(1) Piston Ring Compressor

(a) Combustion Chamber

(b) Gap of Compression Ring 1

(c) Gap of Compression Ring 2

(d) Gap of Oil Ring

Piston Ring and Connecting Rod

1. Remove the piston rings using a piston ring tool.
2. Put the parting mark (for example, ↑) (9) on the piston head as shown in photograph.
3. Remove the piston pin (1), and separate the connecting rod (7) from the piston (2).

(When reassembling)

- When installing the ring, assemble the rings so that the manufacturer's mark (13) near the gap faces the top of the piston.
- When installing the oil ring onto the piston, place the expander joint (11) on the opposite side of the oil ring gap (12).
- Apply engine oil to the piston pin.
- When installing the piston pin, immerse the piston in 80°C (176°F) oil for 10 to 15 minutes and insert the piston pin to the piston.
- When installing the connecting rod to the piston, align the mark (10) on the connecting rod to the parting mark (9).

■ IMPORTANT

- Mark the same number on the connecting rod and the piston so as not to change the combination.

- (1) Piston Pin
- (2) Piston
- (3) Piston Pin Snap Ring
- (4) Compression ring 1
- (5) Compression Ring 2
- (6) Oil Ring
- (7) Connecting Rod
- (8) Connecting Rod Cap
- (9) parting Mark
- (10) Mark
- (11) Expander Joint
- (12) Oil Ring Gap
- (13) Manufacturer's Mark

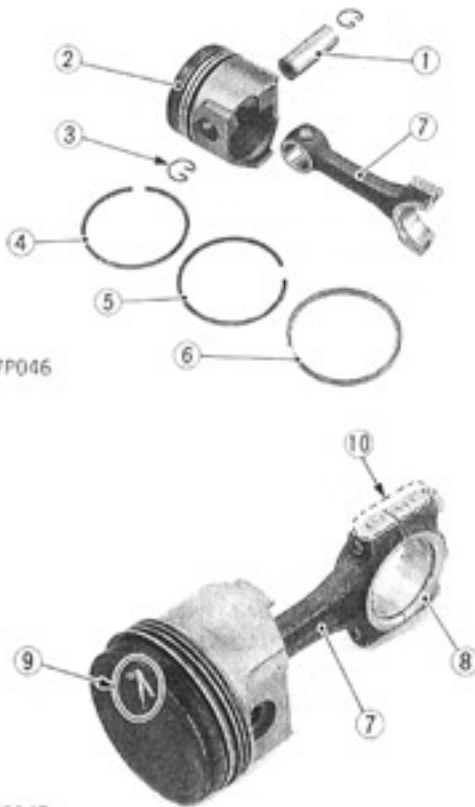

0107P046

0107P047

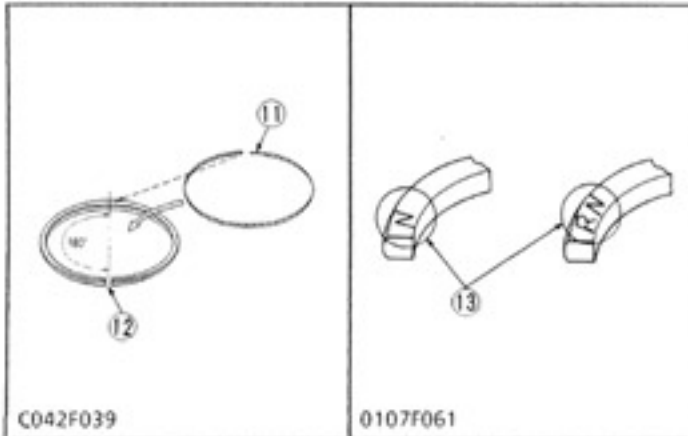

C042F039

0107F061

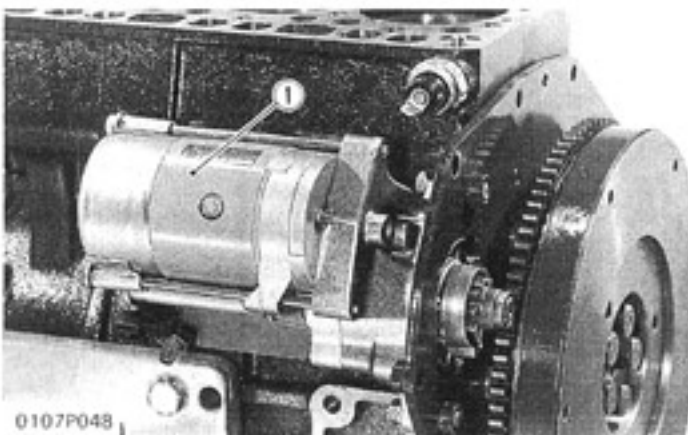
[6] FLYWHEEL AND CRANKSHAFT

0107P048

Starter

1. Remove the starter (1).

- (1) Starter

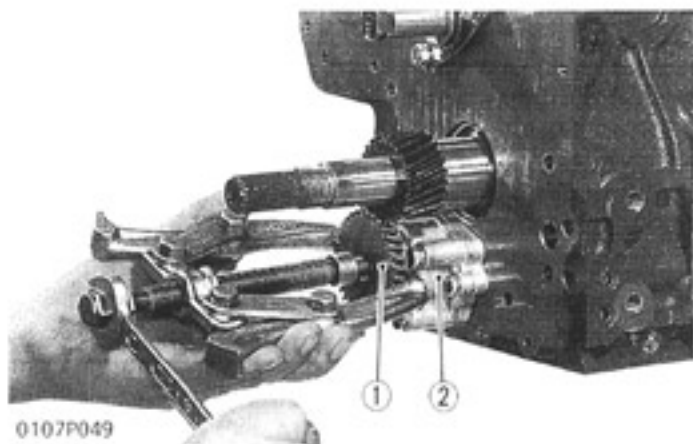

0107P049

Oil Pump

1. Straighten the claw washer, and remove the nut.
2. Pull out the oil pump drive gear (1) with a puller.
3. Remove the oil pump mounting bolts.
4. Remove the oil pump (2).

- (1) Oil Pump Drive Gear
(2) Oil Pump

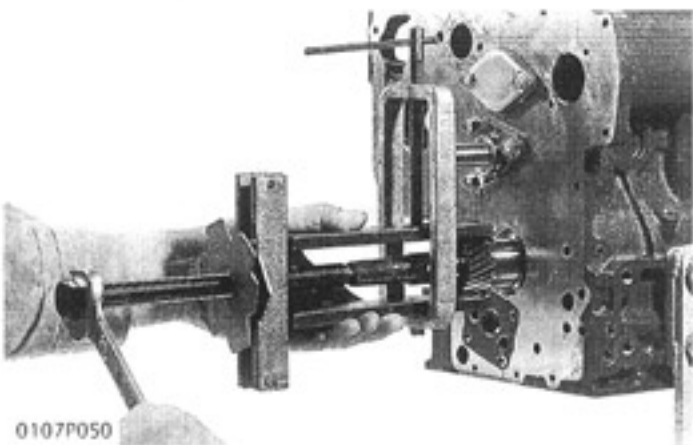

0107P050

Crank Gear

1. Remove the crank gear with a special-use puller set (Code No: 07916-09032).
2. Remove the feather key on the crankshaft.

(When reassembling)

- Check to see that the feather key is on the crankshaft.
Heat the crank gear to approx. 80°C (176°F), and fit on the crankshaft.

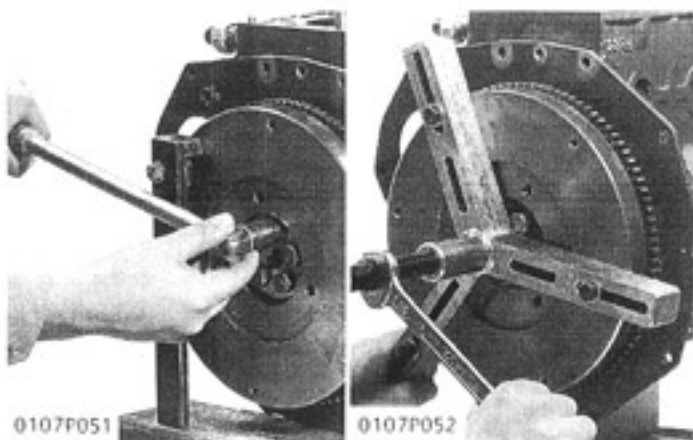

0107P051

0107P052

Flywheel

1. Lock the flywheel not to turn using the flywheel stopper.
2. Remove the flywheel screws, except for two which must be loosened and left as they are.
3. Set a flywheel puller (Code No: 07916-32011), and remove the flywheel.

(When reassembling)

- Apply engine oil to the flywheel screws.

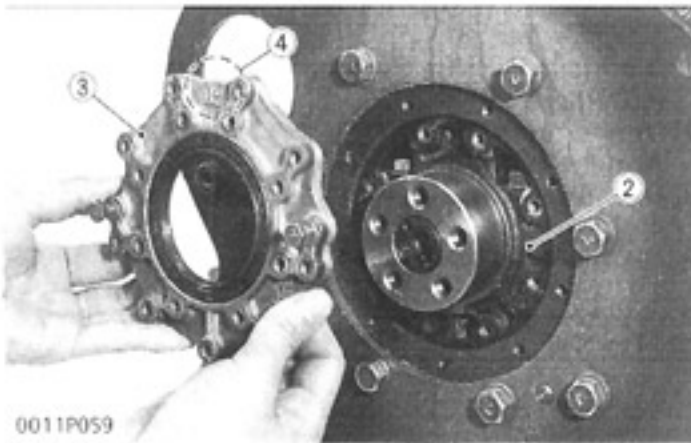

Bearing Case Cover and Crankshaft

NOTE

- Before disassembling, check the side clearance of crankshaft. Also check it during reassembly.

1. Remove the bearing case cover mounting screws.
2. Screw two removed screws into the screw hole of bearing case cover to remove it.
3. Stretch the washer and remove the bearing case screw 2.
4. Pull out the crankshaft.

(When reassembling)

IMPORTANT

- Install the crankshaft sub assembly, aligning the screw hole of main bearing case 2 (2) with the screw hole of cylinder block (1).
- Apply engine oil to the seat and thread of bearing case screw 2. After tightening it, bend the washer firmly.
- Install the bearing case cover (3) to position the casting mark "上" on it upward.
- Tighten the bearing case cover mounting screws with even force on the diagonal line.

- (1) Cylinder Block
 (2) Main Bearing Case 2
 (3) Bearing Case Cover
 (4) Top Mark (上)

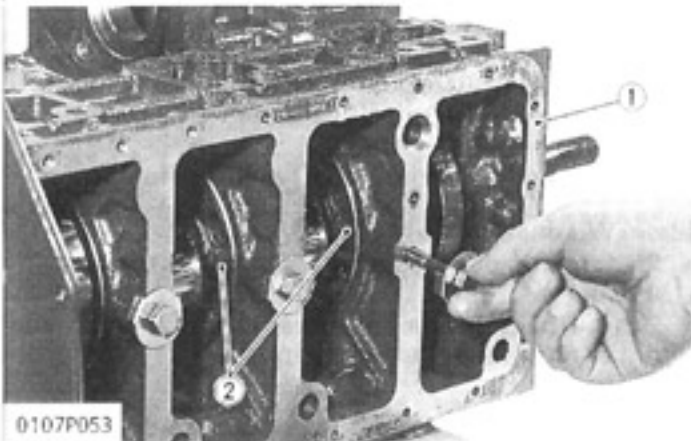

Main Bearing Case Assembly

1. Remove the two bearing case screws 1, and remove the main bearing case assembly 1 (3), being careful with the thrust bearing (2) and crankshaft bearing 2.
2. Remove the main bearing case assemblies 2, 3, as above.

(When reassembling)

- Clean the oil passage in the main bearing case.
- Apply clean engine oil on the crankshaft bearing 2 and thrust bearings.
- Install the main bearing case assemblies in the original positions. They are not interchangeable.
- When installing the main bearing case assemblies 2, 3, face the mark "Fガワ" to the flywheel.
- Be sure to install the thrust bearing with its oil groove facing outward.

- (1) Main Bearing Case Assembly 2
 (2) Thrust Bearing
 (3) Main Bearing Case Assembly 1



SERVICING

[1] CYLINDER HEAD

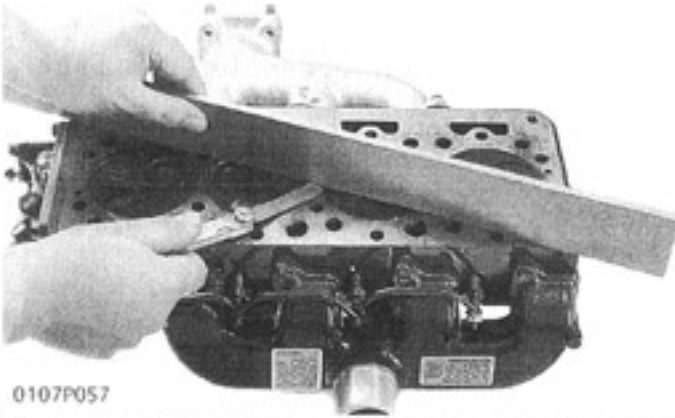

0107P057

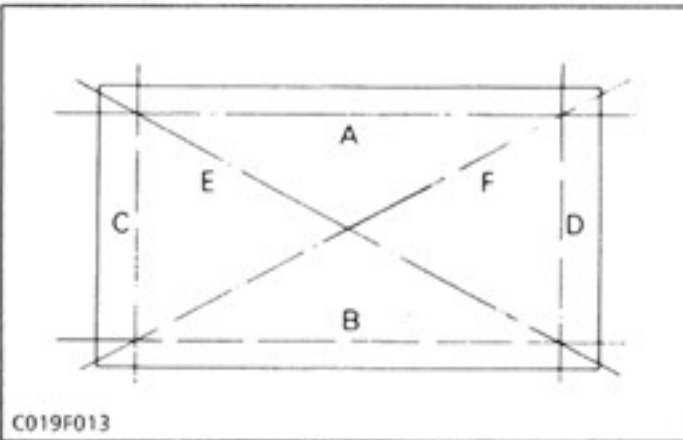

C019F013

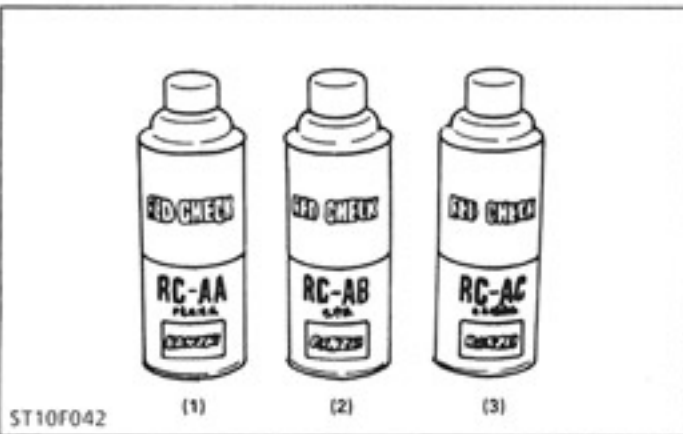

ST10F042

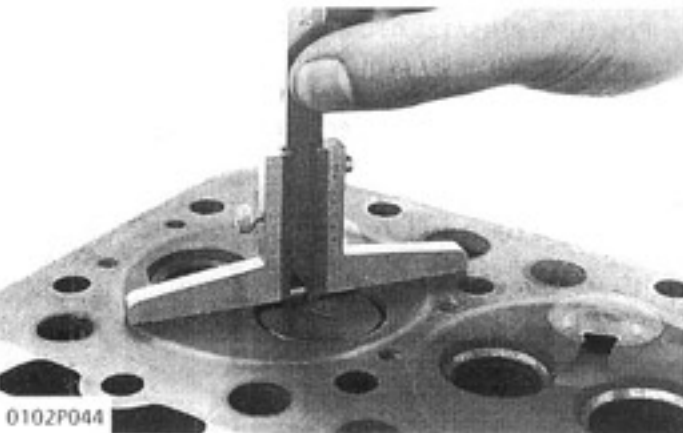

0102P044

Cylinder Head Surface Flatness

1. Thoroughly clean the cylinder head surface.
2. Place a straightedge on the cylinder head's four sides and two diagonal as shown in the figure. Measure the clearance with a feeler gauge.
3. If the measurement exceeds the allowable limit, correct it with a surface grinder.

■ NOTE

- Do not place the straight edge on the combustion chamber.

■ IMPORTANT

- Be sure to check the valve recessing after correcting.

Cylinder Head Flaw

1. Prepare an air spray red check (Code No: 07909-31371).
2. Clean the surface of the cylinder head with detergent (1).
3. Spray the cylinder head surface with the red permeative liquid (2). Leave it five to ten minutes after spraying.
4. Wash away the red permeative liquid on the cylinder head surface with the detergent (1).
5. Spray the cylinder head surface with white developer (3). If flawed, it can be identified as red marks.

Valve Recessing

1. Clean the cylinder head, the valve face and seat.
2. Insert the valve into guide.
3. Measure the valve recessing with a depth gauge.
4. If the measurement exceeds the allowable limit, replace the valve.
If it still exceeds the allowable limit after replacing the valve, correct the valve seat face of the cylinder head with a valve seat cutter (Code No: 07909-33102) or valve seat grinder. Then, correct the cylinder head surface with a surface grinder. Or, replace the cylinder head.

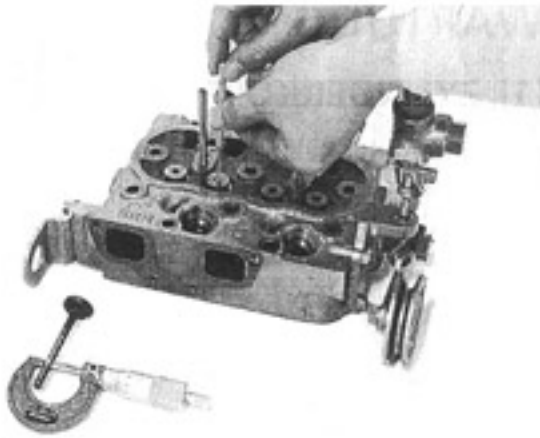

Clearance between Valve Stem and guide

1. Remove carbon from the valve guide section.
2. Measure the valve stem O.D. with an outside micrometer.
3. Measure the valve guide I.D. of the cylinder head at the most wear part as shown in the figure below with a small hole gauge. And calculate the clearance.
4. If the clearance exceeds the allowable limit, replace the valves. If it still exceeds the allowable limit, replace the valve guide.

Correcting Valve and Valve Seat

NOTE

- Before correcting the valve and seat, check the valve stem and the I.D. of the valve guide section, and repair them if necessary.
- After correcting the valve seat, be sure to check the valve recessing.

1) Correcting Valve

1. Correct the valve with a valve refacer.

2) Correcting Valve Seat

1. Slightly correct the seat surface with a 45° or 30° valve seat cutter (1) (Code No: 07909-33102).
2. Fitting the valve, check the contact position of the valve face and seat surface with red lead. (Visual check) [If the valve is used for a long period of time, it deviates to the upper part of the valve face, causing the seat to contact.]
3. Grind the seat surface with a 15° valve seat cutter so that the valve seat width contacts in the same dimensions from the center of the valve face width.
4. Repeatedly lap the valve and seat until the seated rate is more than 70%.

[A] Check Contact

[B] Correct Seat Width

[C] Check Contact

(a) Identical Dimensions

(b) Valve Seat Width

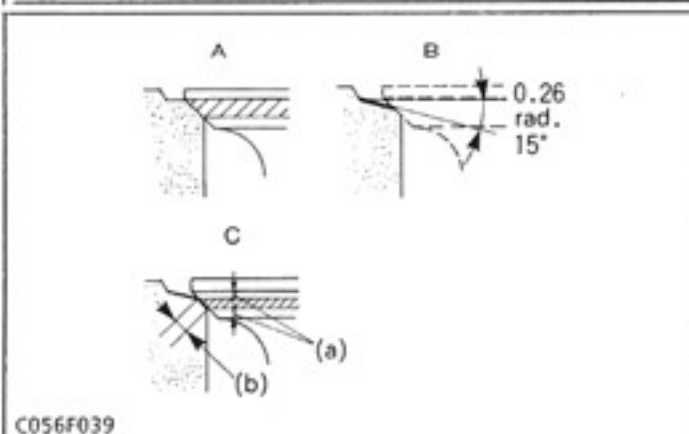
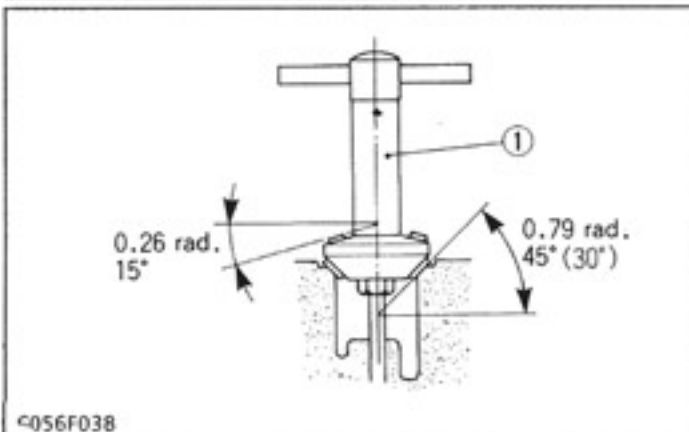
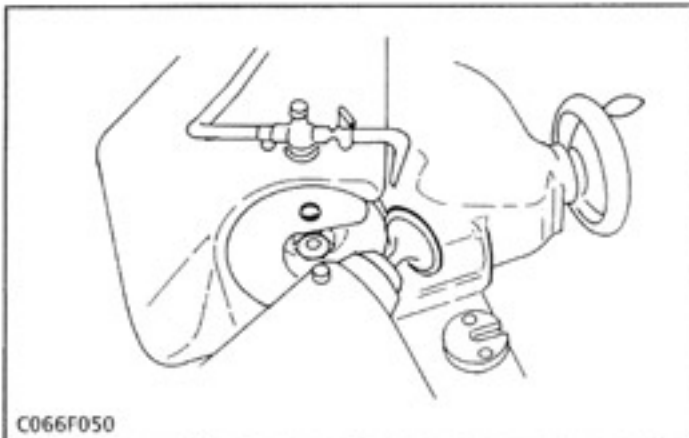

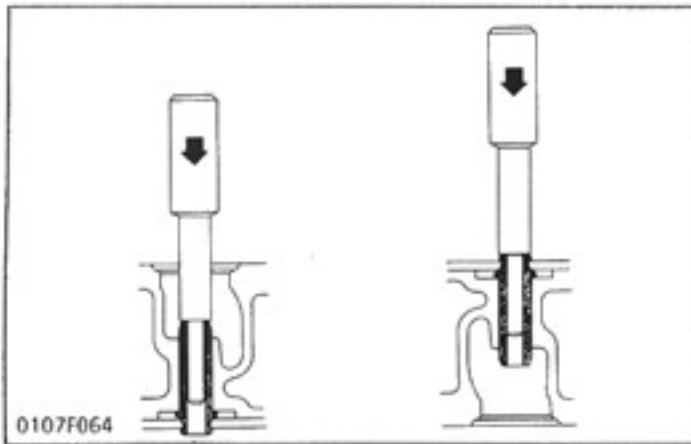

0107F064

Replacing Valve Guide

1. Press the used valve guide out from the cylinder head's lower side using a valve guide replacing tool.
2. Apply engine oil to the outer surface of the new valve guide, and press fit the valve guide from the cylinder head's upper side until the flange part of the valve guide contacts the cylinder head.
3. After press-fitting, finish the valve guide by means of reaming to dimensions shown in previous table.

NOTE

- Be careful not to strike valve guide with a hammer, etc. during replacement.

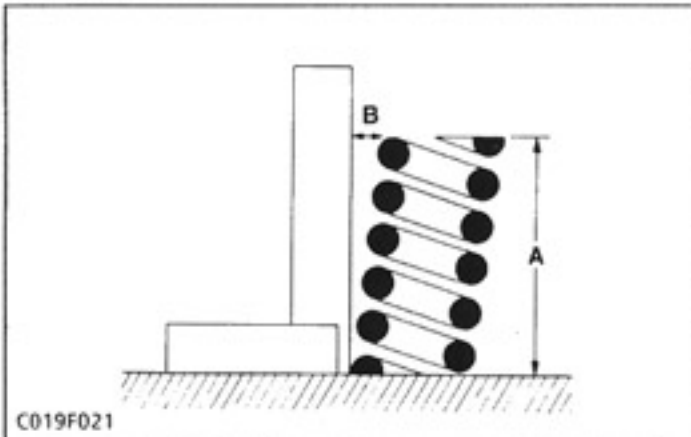

C019F021

Free Length and Tilt of Valve Spring

1. Measure the length A with vernier calipers. If the measurement is less than the allowable limit, replace.
2. Put the spring on a surface plate, place a square on the side of the spring, and check to see if the entire side is in contact with the square. Rotate the spring and measure the maximum B. If the measurement exceeds the allowable limit, replace.
3. Check the entire surface of the spring for scratches. Replace it, if any.

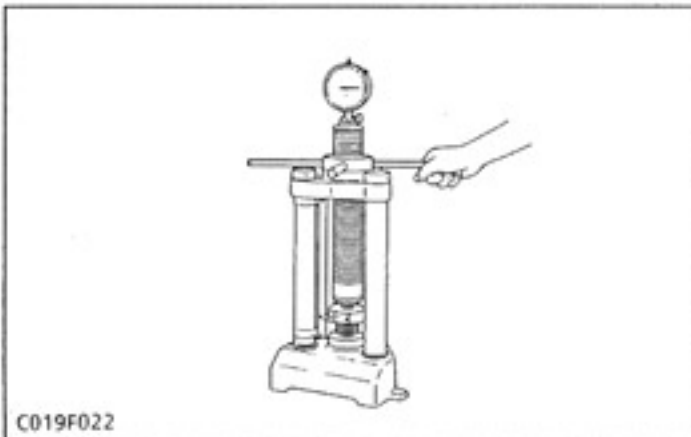

C019F022

Valve Spring Setting Load

1. Place the spring on a tester and compress it to the same length it is actually compressed in the engine.
2. Read the compression load on the gauge.
3. If the measurement exceeds the allowable limit, replace it.



0107P058

Oil Clearance of Rocker Arm Shaft and Bearing

1. Measure the rocker arm bearing I.D. with an inside micrometer.
2. Measure the rocker arm shaft O.D. with an outside micrometer, and then calculate the oil clearance.
3. If the clearance exceeds the allowable limit, replace the rocker arm and measure the oil clearance again. If it still exceeds the allowable limit, replace also the rocker arm shaft.

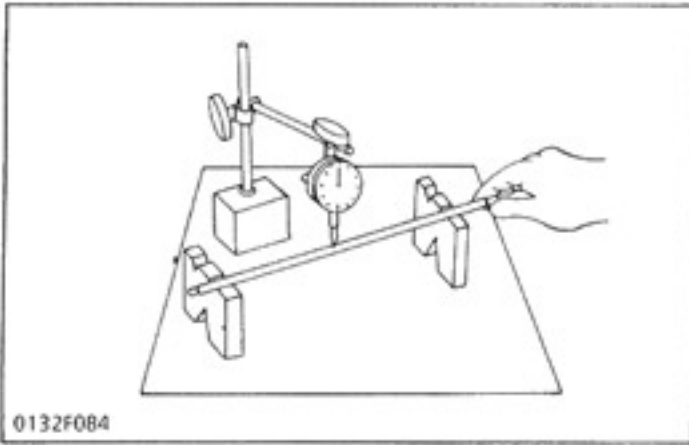

Push Rod Alignment

1. Check the both end of the push rod for cracks, damage and unusual wear.
2. Measure the bending of the push rod with a dial indicator.
3. If the measurement exceeds the allowable limit, replace the push rod.

[2] TIMING GEAR AND CAMSHAFT

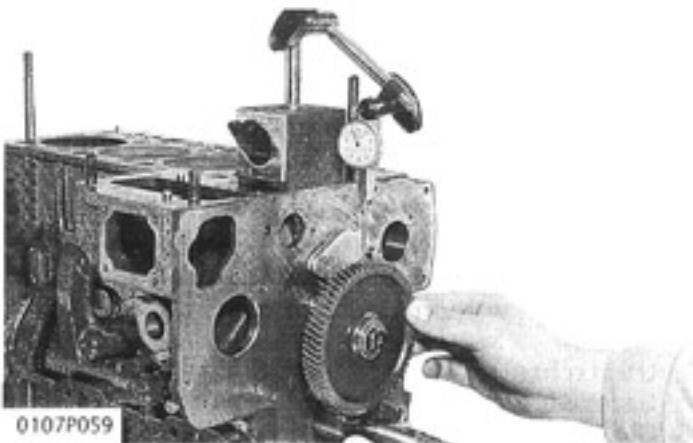

Timing Gear Backlash

1. Set a dial indicator (lever type) with its tip on the gear tooth.
2. Move the gear to measure the backlash, holding its mating gear.
3. If the backlash exceeds the allowable limit, check the oil clearance of the shafts and gear.
4. If the oil clearance is proper, replace the gear.

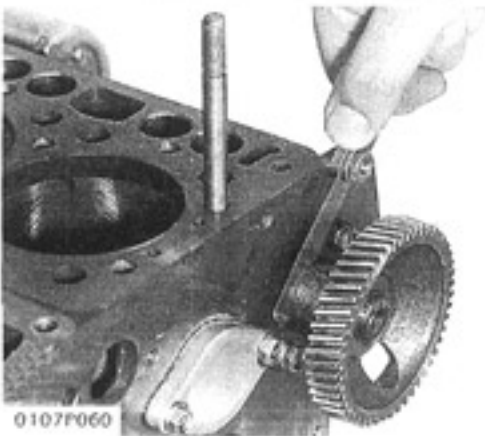

End Play of Camshaft

1. Pull the cam gear with the camshaft to its end.
2. Measure the clearance between the cam gear and camshaft stopper.
3. If the clearance exceeds the allowable limit, replace the camshaft stopper.

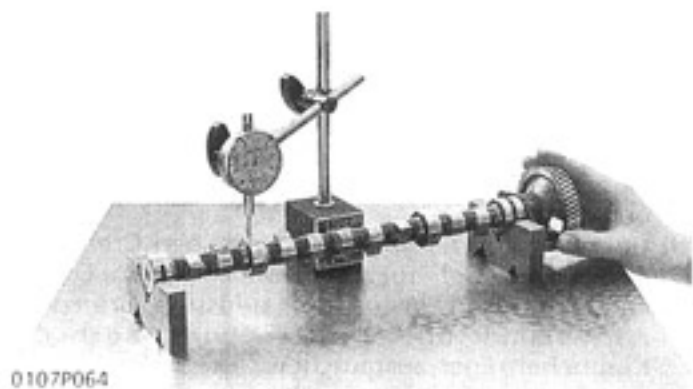

Camshaft Alignment

1. Support the camshaft with V-blocks on the surface plate and set a dial indicator with its tip on the intermediate journal at right angle.
2. Rotate the camshaft on the V-blocks and get the misalignment (half of the measurement).
3. If the misalignment exceeds the allowable limit, replace the camshaft.

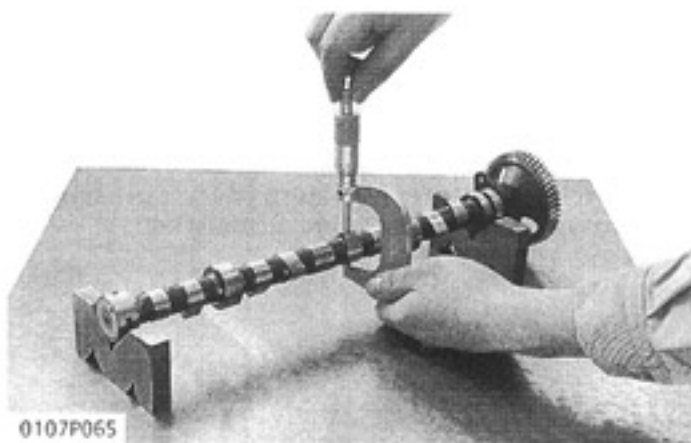

Intake and Exhaust Cam Height

1. Measure the height of the cam at its highest point with an outside micrometer.
2. If the measurement is less than the allowable limit, replace it.

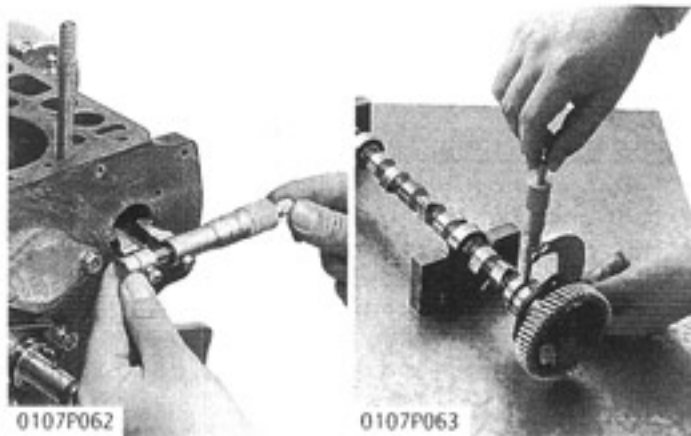

Oil Clearance of Camshaft Journal

1. Measure the camshaft journal O.D. with an outside micrometer.
2. Measure the cylinder block bore I.D. for camshaft with an inside micrometer. Calculate the oil clearance.
3. If the clearance exceeds the allowable limit, replace the camshaft.

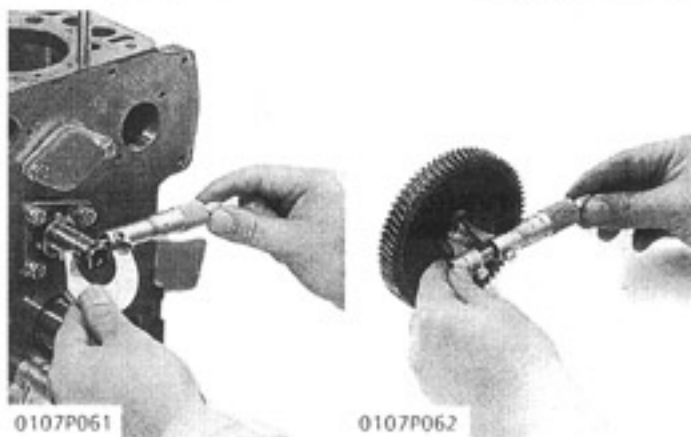

Clearance between Idle Gear Shaft and Idle Gear Bushings

1. Measure the idle gear shaft O.D. with an outside micrometer.
2. Measure the idle gear bushings I.D. with an inside micrometer, and calculate the clearance.
3. If the clearance exceeds the allowable limit, replace the bushing.

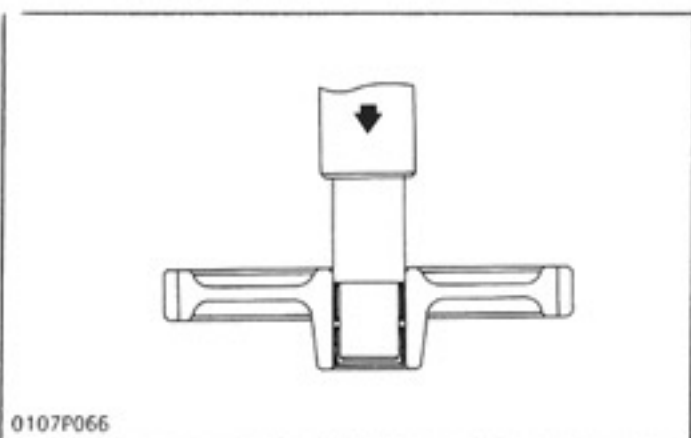

Replacing Idle Gear Bushings

1. Press the used bushings out using a idle gear bushing replacing tool.
2. Press fit new bushings.

[3] PISTON AND CONNECTING ROD



0107P066

Piston Pin-Bore I.D.

1. Measure the I.D. of the piston pin-bore in both the horizontal and vertical directions with a cylinder gauge.
2. If the measurement exceeds the allowable limit, replace the piston.

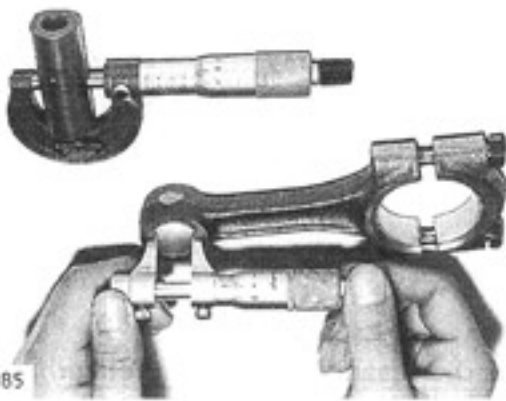

0011P085

Oil Clearance between Piston Pin and Small End

Bushing

1. Measure the O.D. of the piston pin where it contacts the bushing with an outside micrometer.
2. Measure the I.D. of the piston pin bushing at the connecting rod small end with a cylinder gauge. Calculate the oil clearance.
3. If the clearance exceeds the allowable limit, replace the bushing. If it still exceeds the allowable limit, replace the piston pin.

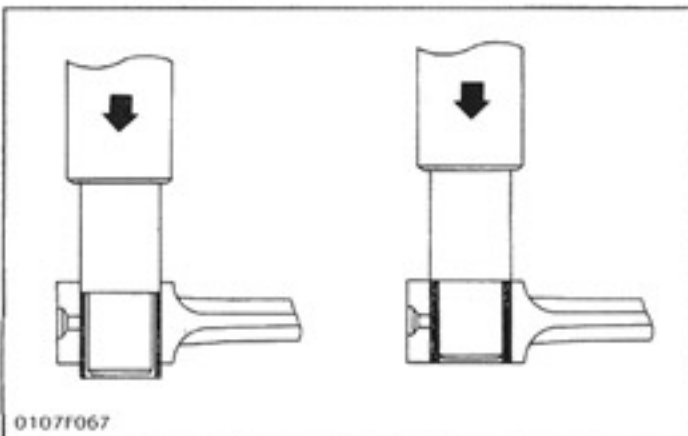

0107F067

Replacing Connecting Rod Small End Bushing

(When removing)

1. Press out the small end bushing with a connecting rod small end bushing replacing tool.

(When installing)

1. Clean a new small end bushing and bore, and apply engine oil to them.
2. Insert a new bushing onto the tool and press-fit it with a press so that the seam (1) of bushing positions as shown in the figure, until it is flush with the connecting rod.

(1) Seam

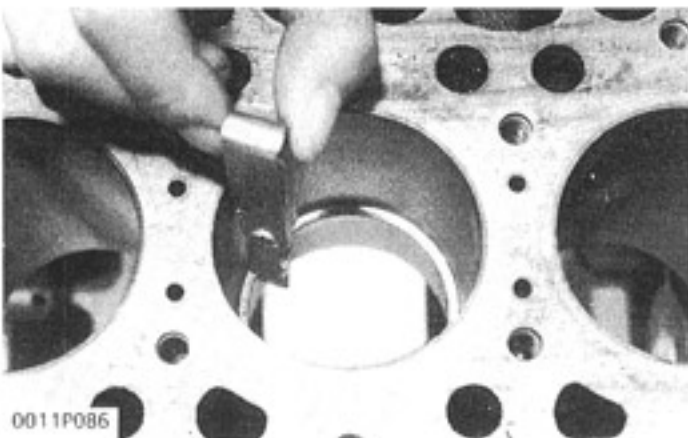

0011P086

Piston Ring Gap

1. Insert the piston ring into the lower part of the liner (the least worn out part) with the piston.
2. Measure the ring gap with a feeler gauge.
3. If the gap exceeds the allowable limit, replace the ring.

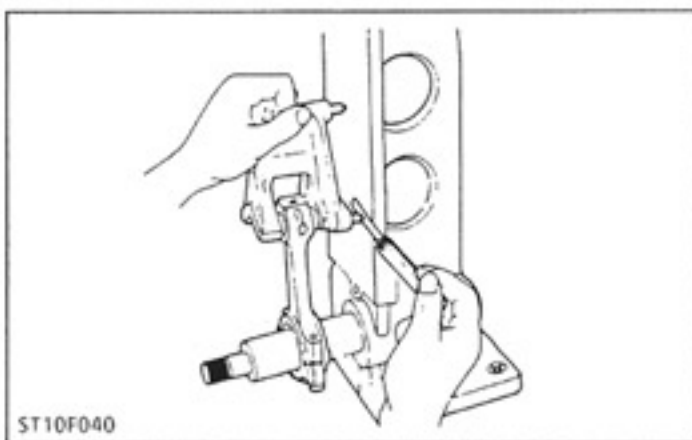
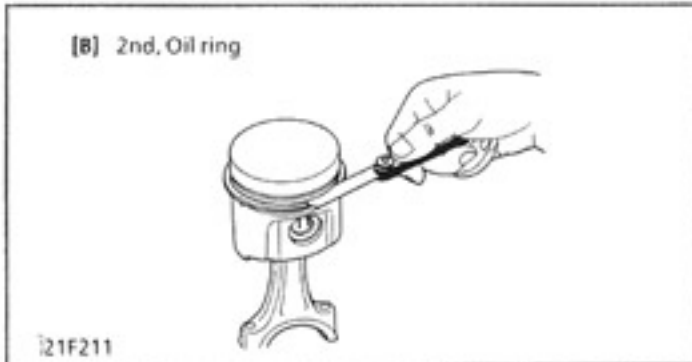
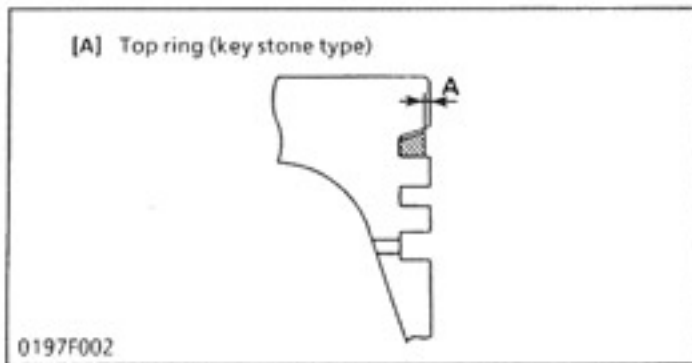

Clearance between Piston Ring and Groove

1. Remove carbon from the ring grooves.
2. Measure the clearance between the ring and the groove with a feeler gauge or depth gauge.
3. If the clearance exceeds allowable limit, replace the ring since compression leak and oil shortage result.
4. If the clearance still exceeds the allowable limit after replacing the ring, replace the piston.

Factory specification : A

More than 0.2 mm

Connecting Rod Alignment

■ NOTE

- Since the I.D. of the connecting rod small end bushing is the basis of this check, check the bushing for wear beforehand.

1. Install the piston pin into the connecting rod.
2. Install the connecting rod on the connecting rod alignment tool (Code No: 07909-31661).
3. Put a gauge over the piston pin and move it against the face plate.
4. If the gauge does not fit squarely against the face plate, measure the space between the pin of the gauge and the face plate.
5. If the measurement exceeds the allowable limit, replace the connecting rod.

[4] CRANKSHAFT

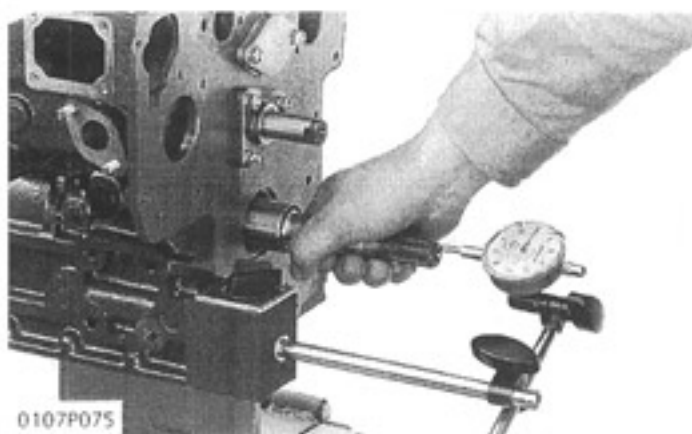

End Play of Crankshaft

1. Move the crankshaft to the flywheel side.
2. Set a dial indicator to the crankshaft.
3. Measure the end play by pulling the crankshaft toward the crank gear.
4. If the measurement exceeds the allowable limit, replace the thrust bearings.

Crankshaft Alignment

1. Support the crankshaft with V-blocks on the surface plate and set a dial indicator with its tip on the intermediate journal at right angle.
2. Rotate the crankshaft on the V-blocks and get the misalignment (half of the measurement).
3. If the misalignment exceeds the allowable limit, replace the crankshaft.

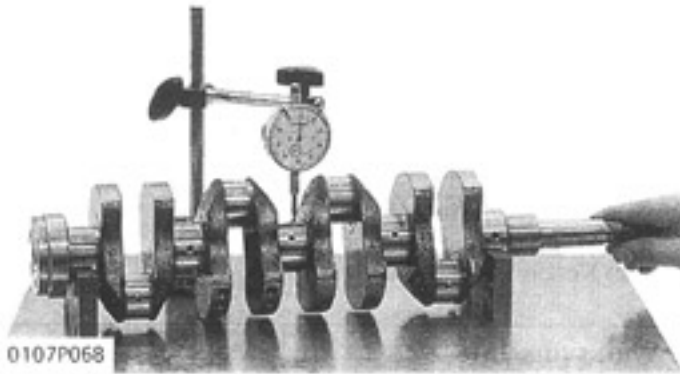

Oil Clearance between Crank Pin and Crank Pin Bearing

Bearing

1. Clean the crank pin and crank pin bearing.
2. Put a strip of press gauge (Code No: 07909-30241) on the center of the crank pin in each direction as shown in the figure.

■ IMPORTANT

- Never insert the press gauge into the crank pin oil hole.

3. Install the connecting rod cap and tighten the screws to the specified torque, and remove the cap again.

■ NOTE

- Fasten the crankshaft so that it does not turn.

4. Measure the amount of the flattening with the scale and get the oil clearance.
5. If the clearance exceeds the allowable limit, replace the bearing.

(Reference)

- When the oil clearance is to be measured by removing the crankshaft, tighten the connecting rod cap with the specified torque, then measure the crank pin bearing I.D. with a cylinder gauge or an inside micrometer. And measure the crank pin O.D. with an outside micrometer. Calculate the oil clearance.

Crankshaft Sleeve Wear

1. Measure the wear of the crankshaft sleeve using a surface roughness tester.
2. If the measurement exceeds the allowable limit, replace the crankshaft sleeve.

(1) Wear

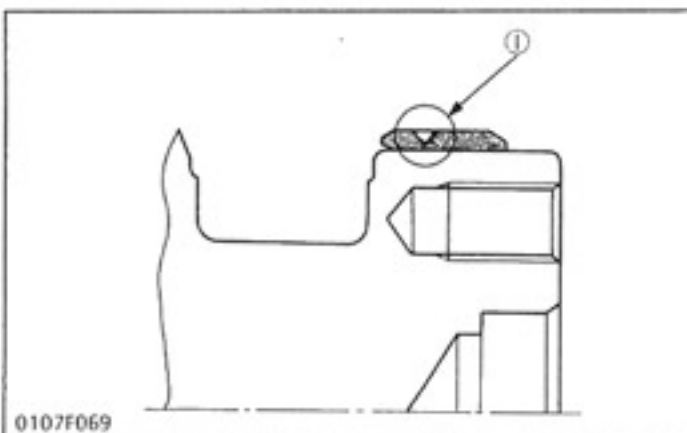
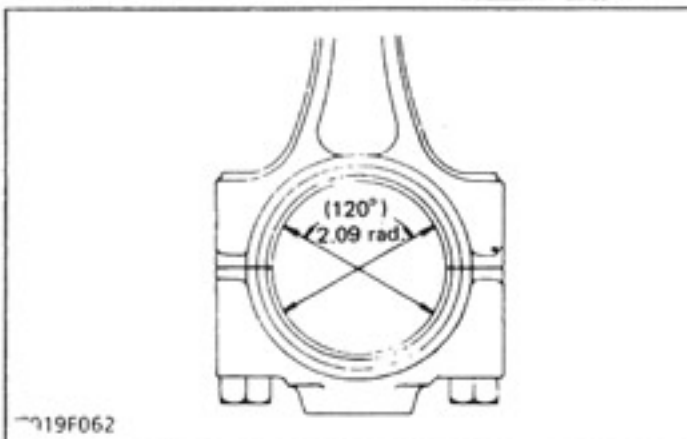
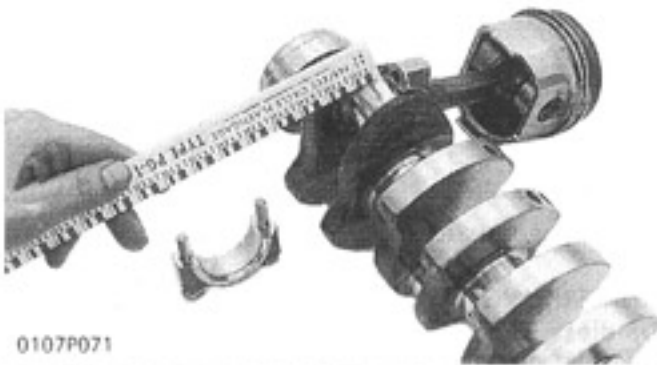

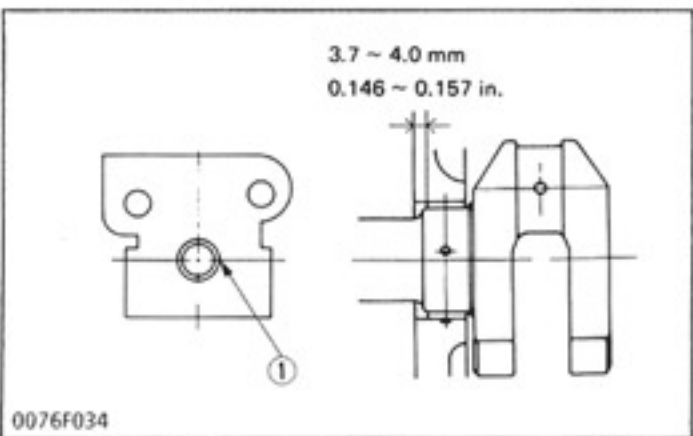
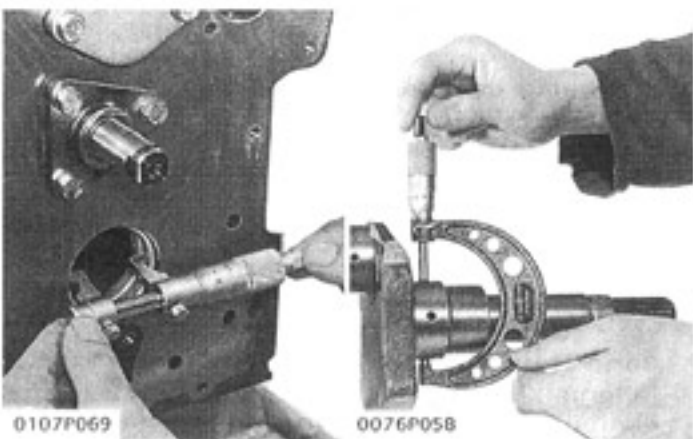
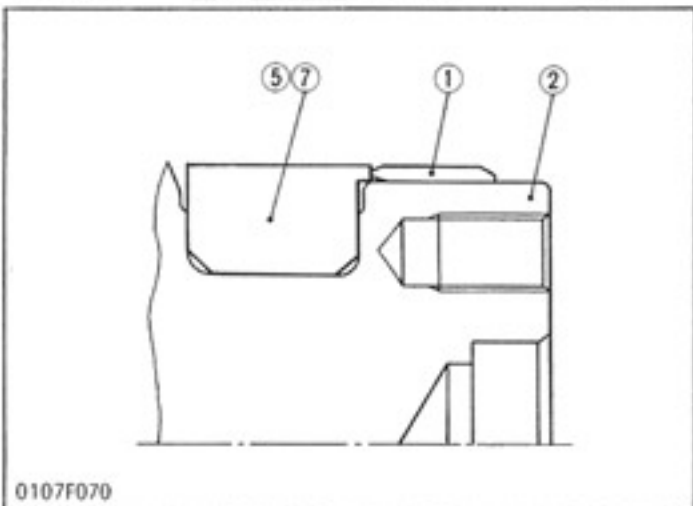
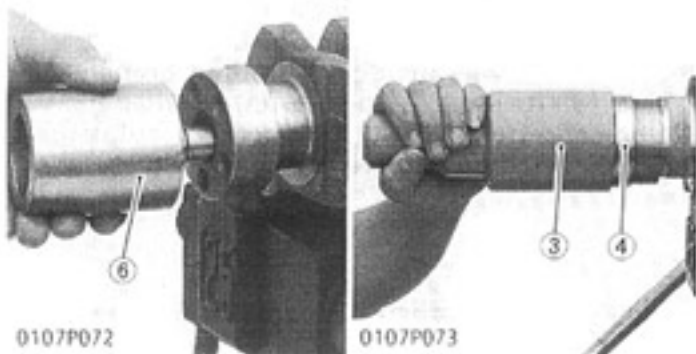

Replacing Crankshaft Sleeve

1. Remove the used crankshaft sleeve using a special-use puller set (Code No:07916-09032).
2. Set the sleeve guide C (6) to the crankshaft.
3. Set the stopper C (7) to the crankshaft as shown in figure.
4. Heat a new sleeve to a temperature between 150 and 200°C (302 and 392°F), and fix the sleeve to the crankshaft as shown in figure.
5. Press fit the sleeve using the auxiliary socket for pushing (3).

- (1) Crankshaft Sleeve
- (2) Crankshaft
- (3) Auxiliary Socket for Pushing
- (4) Sleeve Guide B
- (5) Stopper B
- (6) Sleeve Guide C
- (7) Stopper C

Oil Clearance between Crankshaft Journal and Crankshaft Bearing 1

1. Measure the O.D. of the crankshaft journal with an outside micrometer.
2. Measure the I.D. of the crankshaft bearing 1 with an inside micrometer. Calculate the oil clearance.
3. If the clearance exceeds the allowable limit, replace the crankshaft bearing 1.

Replacing Crankshaft Bearing 1

(When removing)

1. Press out the bearing 1 with crankshaft bearing 1 replacing tool.

(When installing)

1. Clean a new bearing 1 and bore, and apply engine oil to them.
2. Press fit a new bearing 1 using a inserting tool, taking due care to see that the seam of bearing 1 faces the exhaust manifold side.

- (1) Seam

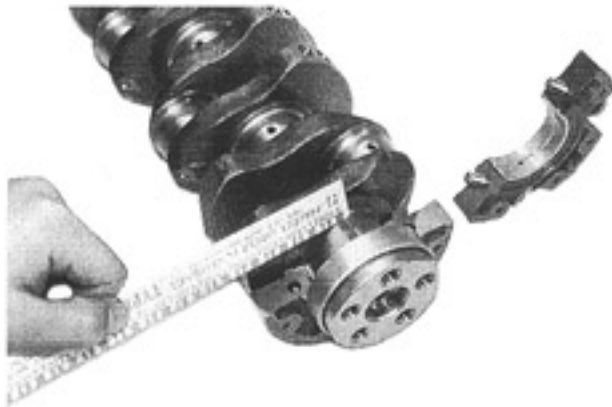

0107P070

Oil Clearance between Crankshaft Journal and Crankshaft Bearing 2 (3, 4, 5)

1. Clean the crankshaft journal and crankshaft bearing.
2. Put a strip of press gauge (Code No: 07909-30241) on the center of the journal.

■ IMPORTANT

- Never insert the press gauge into the oil hole of the journal.
3. Install the main bearing case and tighten the screws to the specified torque, and remove the cases again.
 4. Measure the amount of the flattening with the scale and get the oil clearance.
 5. If the clearance exceeds the allowable limit, replace the crankshaft bearing.

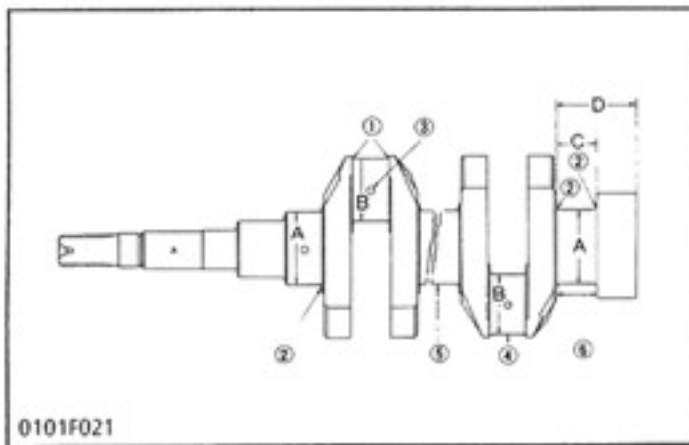

Undersized and Oversized Bearing

If the standard-size bearing cannot be employed due to excessive wear of the crankpin and crank journal, employ undersize or oversize bearings.

For under size or oversize bearing use, follow the precautions noted below.

- Grind the crankpin and journal with a wheel which has specified round corner and width without shoulder.

1. 3.3 to 3.7 mm (0.1300 to 0.1457 in.)
2. 2.8 to 3.2 mm (0.1102 to 0.1260 in.)
3. Be sure to chamfer the oil hole circumference to 1 to 1.5 mm (0.04 to 0.06 in.) radius with an oil stone.
4. The crankpin must be fine-finished to higher than $\nabla\nabla\nabla\nabla$ (0.4-5).
5. The crank journal must be fine-finished to higher than $\nabla\nabla\nabla\nabla$ (0.4-5).
6. The crank journal side surface must be fine-finished to higher than $\nabla\nabla\nabla\nabla$ (0.4-5).

| | | Dimension D |
|---------|-----------------------|---------------------------------------|
| Overize | +0.2 mm +0.008 in. | 48.1 to 48.3 mm 1.894 to 1.902 in. |
| Overize | +0.4 mm +0.016 in. | 48.3 to 48.5 mm 1.902 to 1.909 in. |

| Size | Code No. | Name of bearing | Bearing mark | Crankshaft processing dimension | |
|-----------------------|--------------|-------------------------------------|--------------|---------------------------------|---|
| -0.2 mm -0.008 in. | 15261-2391-1 | Crankshaft bearing 1 (0.2 minus) | 020 US | A | 43.734 to 43.750 mm 1.7218 to 1.7224 in. |
| -0.2 mm -0.008 in. | 15261-2393-1 | Crankshaft bearing 2 (0.2 minus) | 020 US | | |
| -0.4 mm -0.016 in. | 15261-2392-1 | Crankshaft bearing 1 (0.4 minus) | 040 US | | 43.534 to 43.550 mm 1.7140 to 1.7145 in. |
| -0.4 mm -0.016 in. | 15261-2394-1 | Crankshaft bearing 2 (0.4 minus) | 040 US | | |
| -0.2 mm -0.008 in. | 15531-2297-1 | Crank pin bearing (0.2 minus) | 020 US | B | 36.759 to 36.775 mm 1.4473 to 1.4478 in. |
| -0.4 mm -0.016 in. | 15531-2298-1 | Crank pin bearing (0.4 minus) | 040 US | | 36.559 to 36.575 mm 1.4394 to 1.4399 in. |
| +0.2 mm +0.008 in. | 15261-2395-1 | Thrust bearing 1 (0.2 plus) | 020 OS | C | 24.40 to 24.45 mm 0.9763 to 0.9783 in. |
| | 15261-2397-1 | Thrust bearing 2 (0.2 plus) | | | |
| +0.4 mm +0.016 in. | 15261-2396-1 | Thrust bearing 1 (0.4 plus) | 040 OS | | 24.80 to 24.85 mm 0.9763 to 0.9783 in. |
| | 15261-2398-1 | Thrust bearing 2 (0.4 plus) | | | |

[5] CYLINDER LINER

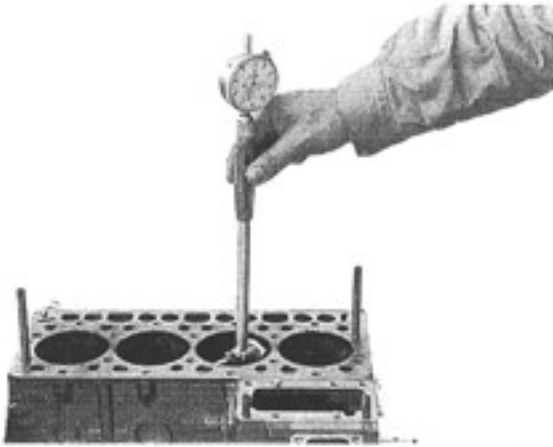

0107P076

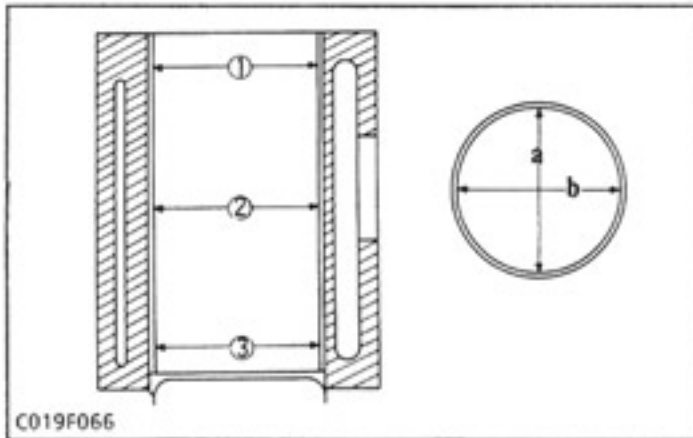

C019F066

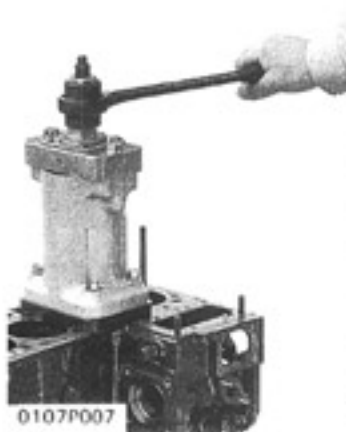

0107P007

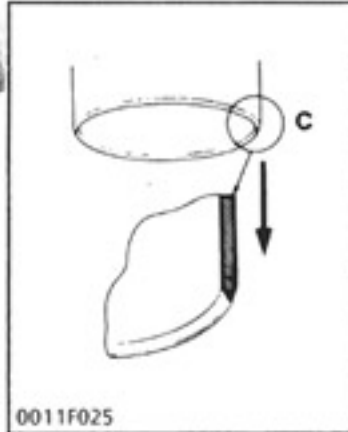

0011F025

Cylinder Liner I.D. (Maximum Wear)

1. Measure the six points shown in the figure with a cylinder gauge to find out the maximum wear. Generally, position (1) in the (a, b) direction (at about 10 mm (0.4 in.) from the top) shows the maximum wear. Since position (3) at the lower part of the liner will show the minimum wear, find this difference.
2. If the measurement exceeds the allowable limit, replace the cylinder liner.

Replacing Cylinder Liner

1. Install the dry liner changer-II (Code No: 07916-33081) on the cylinder block and pull out the liner.
2. Clean the fitting surface of the liner and cylinder block, and apply engine oil to them.
3. Press-fit the new cylinder liner into the cylinder block so that its end comes flush with cylinder block.
4. Bore and hone to the specified dimension.

■ IMPORTANT

- Insert the liner with its chamfered end C to the interior.

2 LUBRICATING SYSTEM

CHECKING

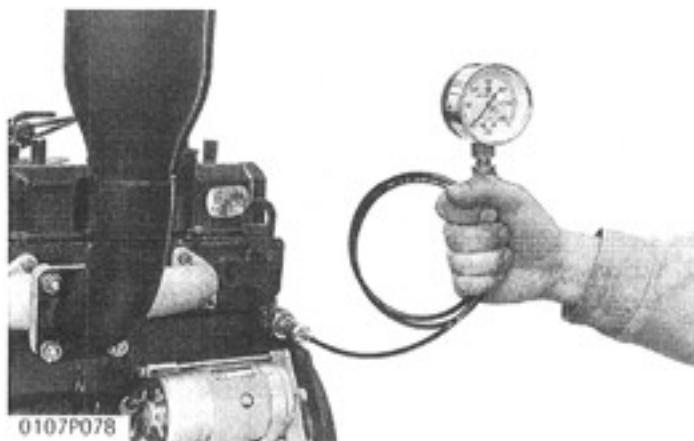

Engine Oil Pressure

1. Remove the oil switch and set a pressure tester (Code No: 07916-32031).
2. Start the engine. After warming up, measure the oil pressure of both idling and rated speeds.
3. If the oil pressure is less than the allowable limit, check the following.
 - Engine oil insufficient
 - Oil pump defective
 - Oil strainer clogged
 - Oil gallery clogged
 - Excessive oil clearance of bearing
 - Foreign matter in the relief valve

DISASSEMBLING AND ASSEMBLING



Oil Strainer

1. Detach the oil pan by lightly tapping the groove of the pan with a wooden hammer.
2. Remove the mounting bolt of oil filter.
3. Detach oil filter 1, being careful of the O-ring.



Oil Pump

1. Straighten the claw of the claw washer of the oil pump, and remove the nut.
2. Draw out the oil pump drive gear with gear puller.
3. Remove the four oil pump mounting bolts. Detach the oil pump.

SERVICING

[1] OIL PUMP

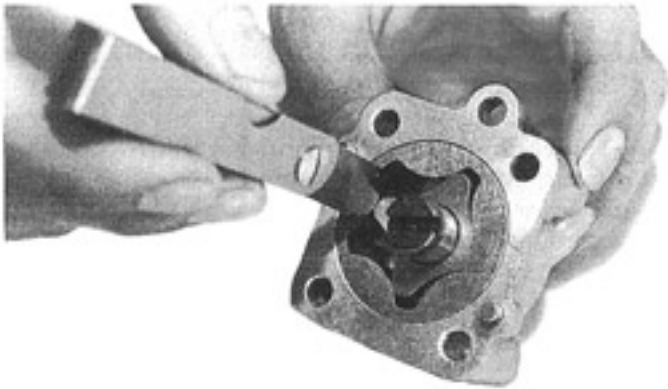

0011P100

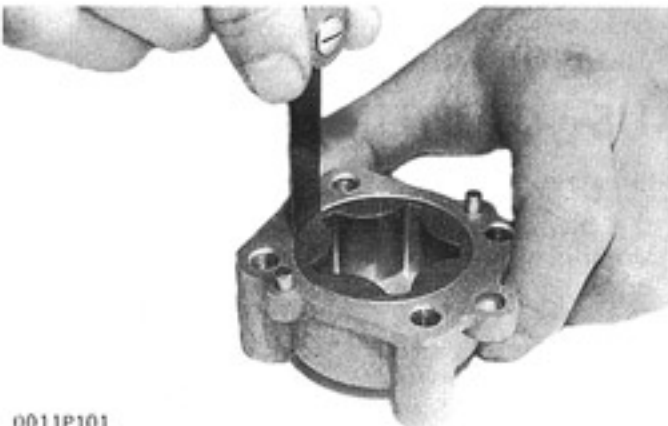

0011P101

Rotor Lobe Clearance

1. Measure the clearance between lobes of the inner rotor and the outer rotor with a feeler gauge.
2. If the clearance exceeds the allowable limit, replace the oil pump rotor assembly.

Clearance between Outer Rotor and Pump Body

1. Measure the clearance between the outer rotor and the pump body with a feeler gauge.
2. If the clearance exceeds the allowable limit, replace the oil pump rotor assembly.

Clearance between Rotor and Cover

1. Put a strip of press gauge (Code No: 07909-30241) onto the rotor face with grease.
2. Install the cover and tighten the screws.
3. Remove the cover carefully, and measure the width of the press gauge with a sheet of gauge.
4. If the clearance exceeds the allowable limit, replace oil pump rotor assembly.

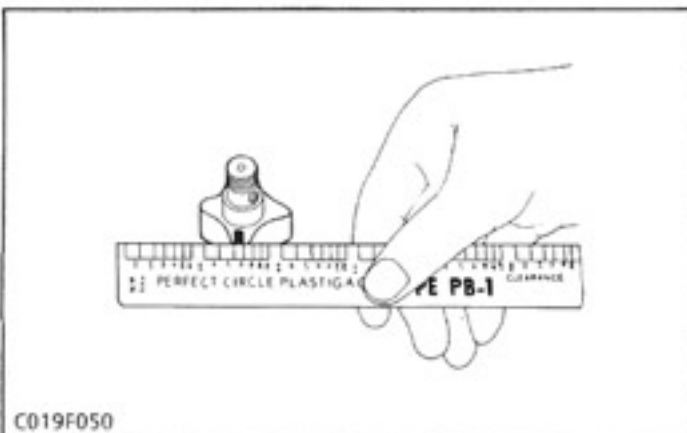

C019F050

3 COOLING SYSTEM

CHECKING

[1] FAN BELT

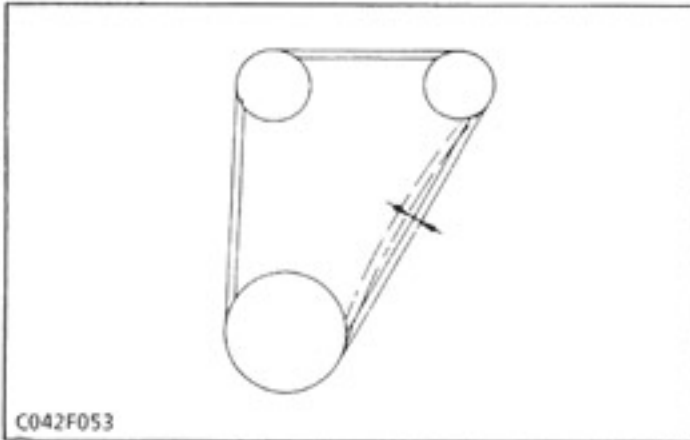

Fan Belt Tension

1. Press the fan belt between fan pulley and pulley with your finger at force of 10 kgf (98N, 22 lbs). Check if the fan belt deflection is 7 to 9 mm (0.28 to 0.35 in.)
2. If the deflection is not within the factory specifications, adjust with the tension pulley adjusting nut.



Thermostat's Valve Opening Temperature

1. Push down the thermostat valve and insert a string between the valve and the valve seat.
2. Place the thermostat and a thermometer in a container with water and gradually heat the water.
3. Hold the string to suspend the thermostat in the water. When the water temperature rises, the thermostat valve will open, allowing it to fall down from the string. Read the temperature at this moment on the thermometer.
4. Continue heating the water and read the temperature when the valve has risen by about 6 mm (0.236 in.).
5. If the measurement is not acceptable, replace the thermostat.

| | | |
|--|---------------|------------------------------------|
| Thermostat's valve opening temperature | Factory spec. | 80.5 to 83.5°C 176.9 to 182.3°F |
| Temperature at which thermostat completely opens | Factory spec. | 95°C 203°F |

[2] RADIATOR

⚠ CAUTION

- When removing the radiator cap, wait at least ten minutes after the engine has stopped and cooled down. Otherwise, hot water may gush out, scalding nearby people.

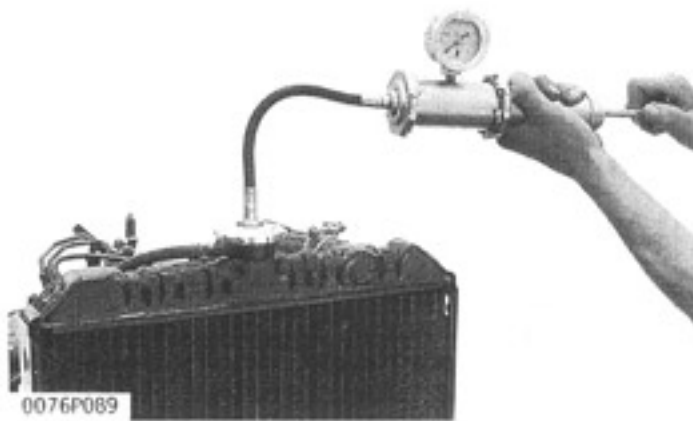

0076P089

Radiator Water Leakage

1. Pour a specified amount of water into the radiator.
2. Set a radiator tester (Code No: 07909-31551). Increase water pressure to the specified pressure of 1.4 kgf/cm² (137 kPa, 20 psi).
3. Check each section for water leakage.
4. When water leakage is excessive, replace the radiator. If water leakage is caused by a small pinhole, correct the radiator with radiator cement.

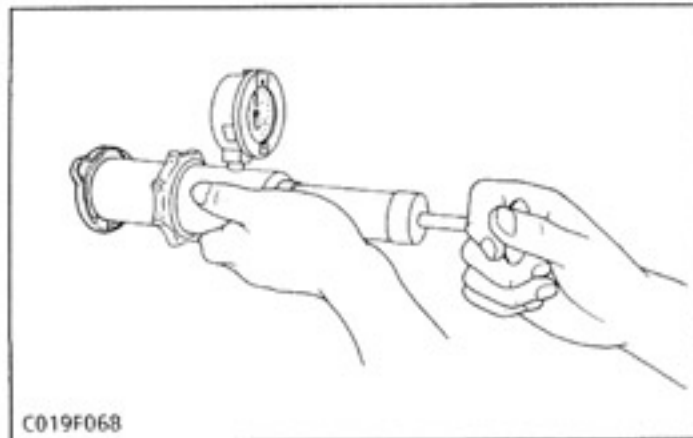

C019F068

Radiator Cap Air Leakage

1. Set a radiator tester (Code No: 07909-31551) to the radiator cap.
2. Apply the specified pressure of 0.9 kgf/cm² (98.1 kPa, 12.8 psi).
3. Check if the pressure drop to less than 0.6 kgf/cm² (59 kPa, 9 psi) in 10 seconds.
4. If the pressure is less than the factory specification, replace it.

DISASSEMBLING AND ASSEMBLING

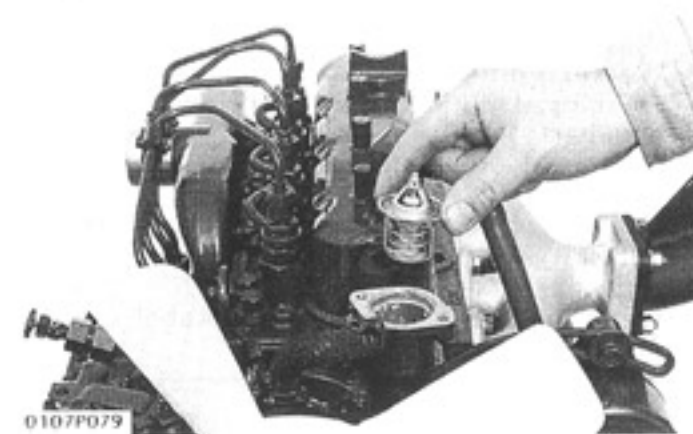

0107P079

Thermostat

1. Remove the thermostat cover.
2. Remove the thermostat.

(When reassembling)

- Apply a liquid gasket (Three Bond 1215 or equivalent) only at the thermostat cover side of the gasket.

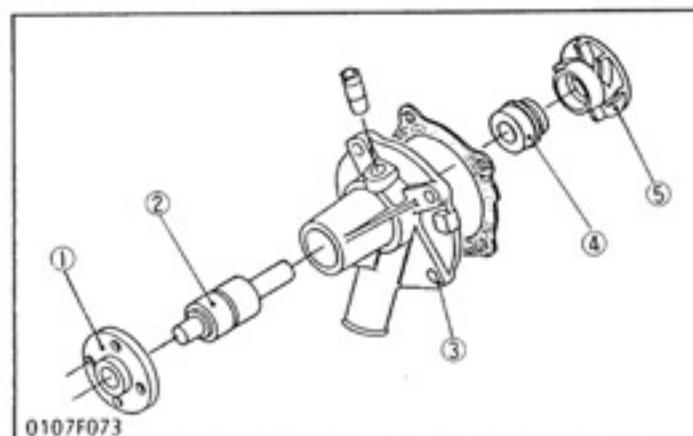

0107F073

Water Pump

1. Remove the fan and fan pulley.
2. Remove the water pump from gear case cover.
3. Remove the water pump flange (1).
4. Press out the water pump shaft (2) with the impeller (5) on it.
5. Remove the impeller from the water pump shaft.
6. Remove the mechanical seal (4).

(When reassembling)

- Replace the mechanical seal with new one.

- (1) Water Pump Flange
- (2) Water Pump Shaft
- (3) Water Pump Body
- (4) Mechanical Seal
- (5) Impeller

4 FUEL SYSTEM

CHECKING AND ADJUSTING

[1] INJECTION PUMP

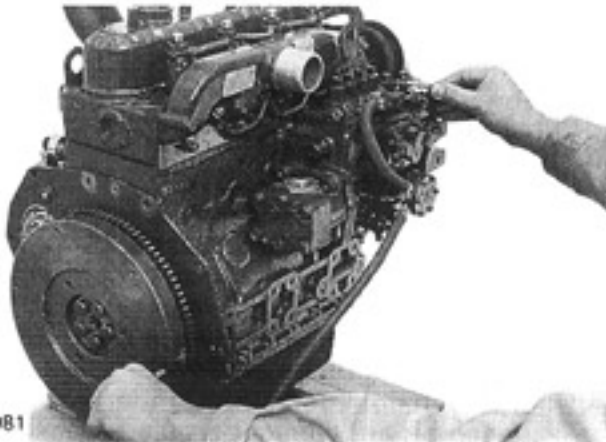

0107P081

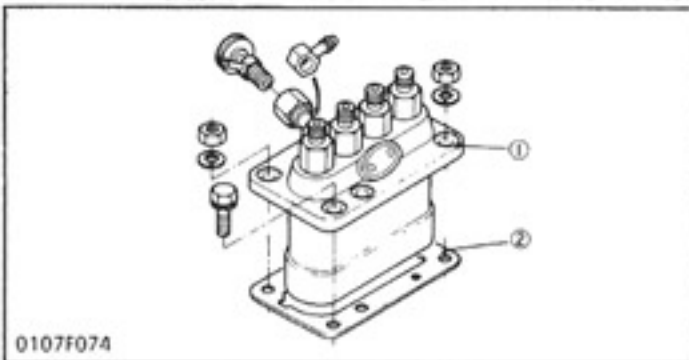

0107F074

Injection Timing

1. Remove the injection pipes.
2. Set the speed control lever for maximum fuel discharge.
3. Turn the flywheel counterclockwise until fuel flows from the delivery valve holder.
4. Continue to turn the flywheel slowly, and stop it as soon as the fuel level at the tip of the delivery valve holder begins to increase.
5. Check to see if the mark "FI" on the flywheel is aligned with the punch mark.
6. If the timing is out of adjustment, readjust the timing with shims (2).

NOTE

- Adding or removing one shim (0.15 mm, 0.0059 in.) varies the crank angle by approx. 1.5° (0.026 rad).

- (1) Injection Pump
(2) Shims

Fuel Tightness of Pump Element

1. Remove the injection pipe.
2. Install the injection pump pressure tester (1) to the injection pump.
3. Set the speed control lever (2) to the maximum speed position.
4. Turn the flywheel ten times or more to increase the pressure.
5. If the pressure can not reach the allowable limit, replace the pump element or injection pump assembly.

- (1) Injection Pump Pressure Tester
(2) Speed control Lever

Fuel Tightness of Delivery Valve

1. Set a pressure tester to the fuel injection pump.
2. Rotate the flywheel to increase the pressure to 150 kgf/cm² (14.7 MPa, 2133 psi).
3. Align the plunger with the bottom dead center.
4. Measure the time needed to decrease the pressure from 150 to 140 kgf/cm² (14.7 to 13.7 MPa, 2133 to 1990 psi).
5. If the measurement is less than allowable limit, replace the delivery valve.

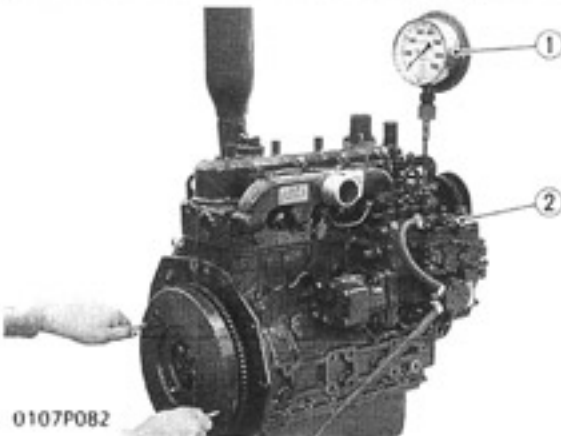

0107P082

[2] INJECTION NOZZLE

⚠ CAUTION

- Check the nozzle injection pressure and condition after confirming that there is nobody standing in the direction the fume goes. If the fume from the nozzle directly contacts the human body, cells may be destroyed and blood poisoning may be caused.

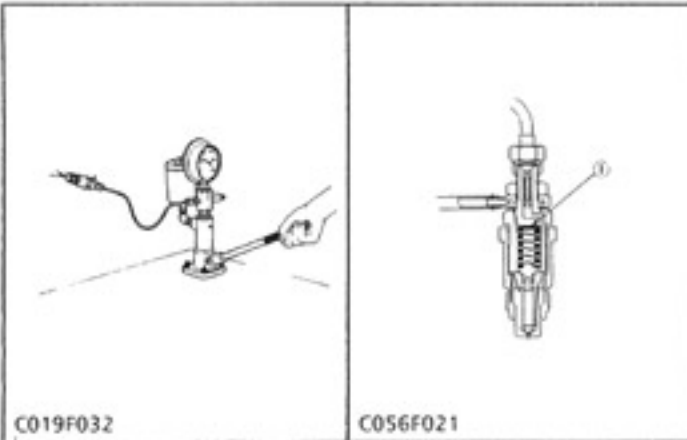

Nozzle Injection Pressure

1. Set the injection nozzle to the nozzle tester.
2. Slowly move the tester handle to measure the pressure at which fuel begins jetting out from the nozzle.
3. If the measurement is not within the factory specifications, disassemble the injection nozzle, and change adjusting washer (1) until the proper injection pressure is obtained.

(Reference)

- Pressure variation with 0.1 mm (0.004 in.) difference of adjusting washer thickness.
Approx. 10 kgf/cm² (981 kPa, 142 psi)

(1) Adjusting Washer

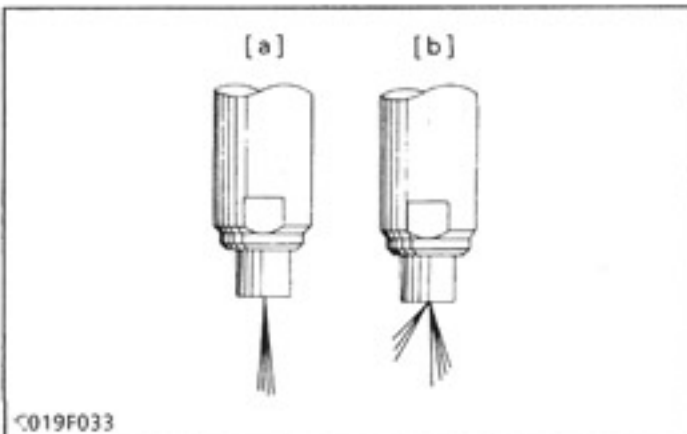

Nozzle Spraying Condition

1. Set the injection nozzle to a nozzle tester and check the nozzle spraying condition.
2. If the spraying condition is defective, replace the nozzle piece.

[a] Good

[b] Bad

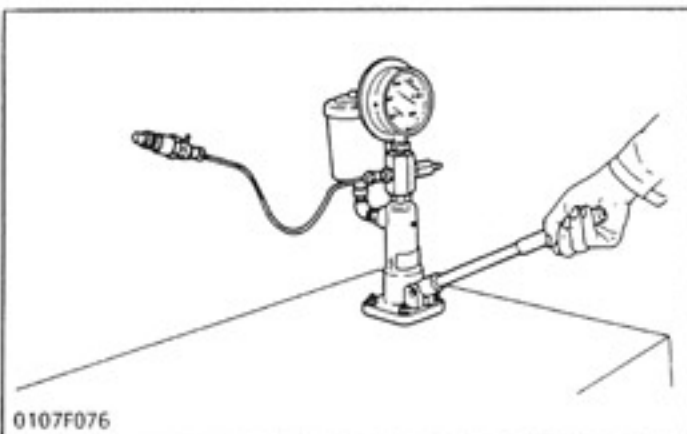

Fuel Tightness of Needle Valve Seat

1. Set the injection nozzle to a nozzle tester.
Apply a pressure 130kgf/cm² (12.75 MPa, 1849 psi).
2. After keeping the nozzle under this pressure for 10 seconds, check to see if fuel leaks from the nozzle.
3. If fuel should leak, replace the nozzle piece.

DISASSEMBLING AND ASSEMBLING

[1] INJECTION PUMP

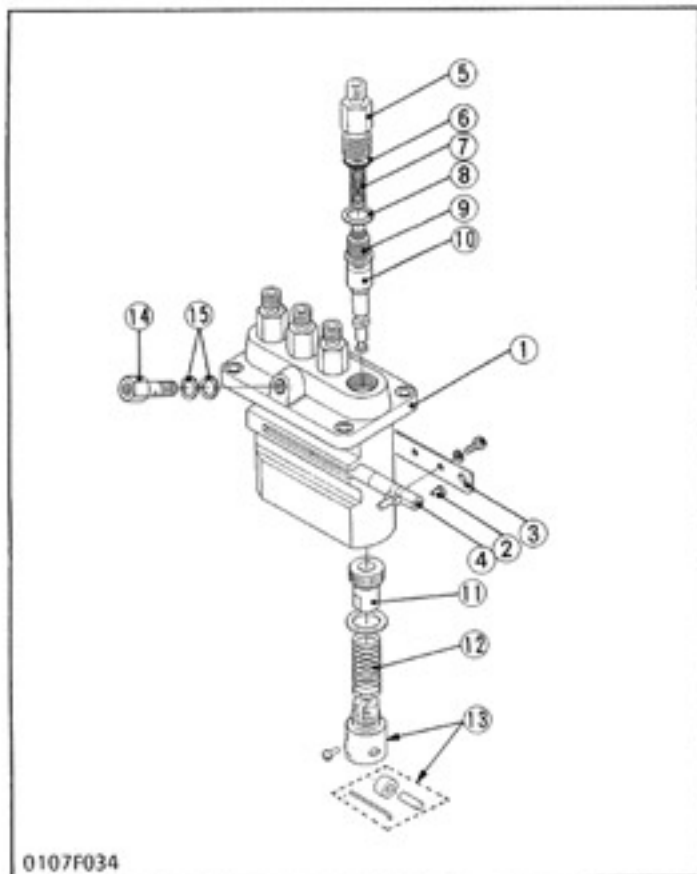

■ IMPORTANT

- If replacing the pump element, the amount of fuel injection should be adjusted on a specified bench.

- (1) Pump Body
- (2) Adjust Plate
- (3) Plate
- (4) Control Rack
- (5) Delivery Valve Holder
- (6) O-ring
- (7) Delivery Valve Spring
- (8) Gasket
- (9) Delivery Valve
- (10) Pump Element
- (11) Control Sleeve
- (12) Plunger Spring
- (13) Tappet
- (14) Hollow Screw
- (15) Gasket

[2] INJECTION NOZZLE



Nozzle Holder

1. Secure the nozzle retaining nut (1) with a vise.
2. Remove the nozzle holder (2), and take out parts inside.

(When reassembling)

- Assemble the nozzle in clean fuel oil.
- Install the push rod (5), noting its direction.
- After assembling the nozzle, be sure to adjust the fuel injection pressure.

- (1) Nozzle Retaining Nut
- (2) Nozzle Holder
- (3) Adjusting Washer
- (4) Nozzle Spring
- (5) Push Rod
- (6) Distance Piece
- (7) Nozzle Piece

5 ELECTRICAL SYSTEM

CHECKING

[1] ALTERNATOR AND REGULATOR

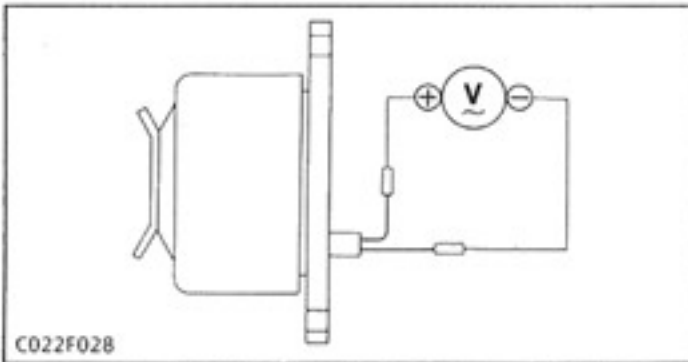

Alternator's No-load Voltage

1. Disconnect the lead wire from the alternator.
2. Start the engine and measure the voltage generated by the alternator.

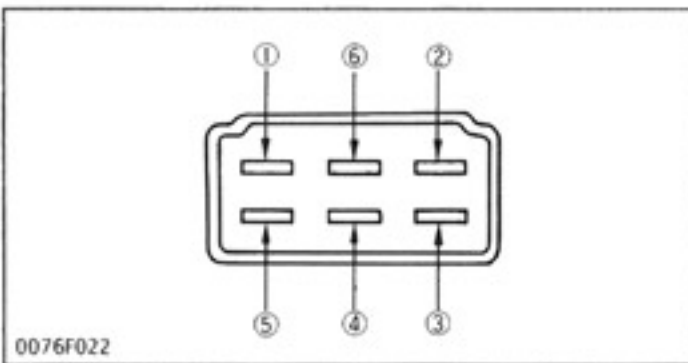

Continuity across Regulator's Terminals

1. Remove the regulator coupler.
2. Check with a tester whether the regulator is in optimum condition or not.

NOTE

- Try to use a high-resistance tester as far as possible.
- The judgment should be as below table.
"ON" if the indicator moves, otherwise "OFF".

Check Table

| Tester -terminal | Tester + terminal | Cord colors | | | | | |
|---------------------|----------------------|-------------|------|-----|--------|-------|-------|
| | | blue | blue | red | yellow | green | black |
| Cord colors | blue | OFF | ON | OFF | OFF | OFF | OFF |
| | blue | OFF | ON | OFF | OFF | OFF | OFF |
| | red | OFF | OFF | ON | OFF | OFF | OFF |
| | yellow | ON | ON | ON | ON | OFF | ON |
| | green | OFF | OFF | OFF | OFF | ON | OFF |
| | black | OFF | OFF | OFF | OFF | OFF | ON |

- | | | |
|------------|-----------|-------------|
| (1) Blue | (1) Bleu | (1) Blau |
| (2) Blue | (2) Bleu | (2) Blau |
| (3) Red | (3) Rouge | (3) Rot |
| (4) Yellow | (4) Jaune | (4) Gelb |
| (5) Green | (5) Vert | (5) Grün |
| (6) Black | (6) Noir | (6) Schwarz |

[2] STARTER

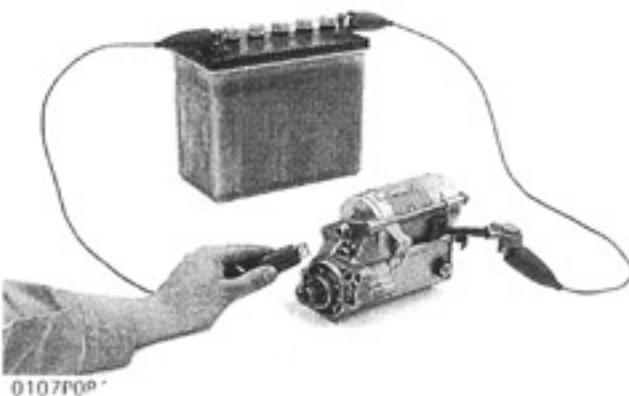

Motor Test

1. Disconnect the connecting lead from the "C" terminal of the starter and connect a jumper lead from the connecting lead to the positive battery terminal.
2. Connect a jumper lead momentarily between the starter body and the negative battery terminal.
3. If the motor does not run, check the motor.

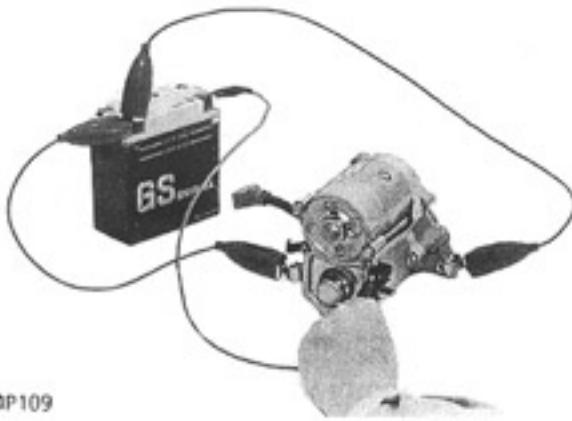

0104P109

Magnet Switch

1. Disconnect the connecting lead from the "C" terminal of the starter.
2. Connect jumper leads from the negative terminal of 6V battery to the body and "C" terminal of the magnet switch.
3. The pinion gear should pop out, when a jumper lead is connected between the positive terminal of the battery to the "S" terminal of the magnet switch.
4. The pinion gear should stay out without the jumper from the negative terminal to the "C" terminal.

■ NOTE

- Each test should be carried out for a short time, about 3 to 5 seconds.

[3] GLOW PLUG

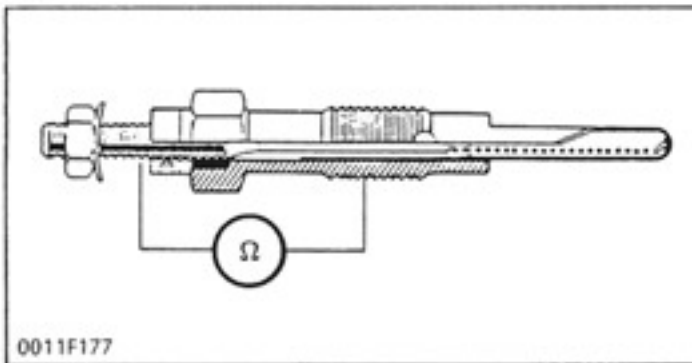

0011F177

Glow Plug

1. Disconnect the leads from the glow plugs.
2. Measure the resistance with a circuit tester across the glow plug terminal and the housing.
3. If 0 ohm is indicated, the screw at the tip of the glow plug and the housing are short-circuited. If the reference value is not indicated, the glow plug is faulty, replace the glow plug.

DISASSEMBLING AND ASSEMBLING

[1] STARTER

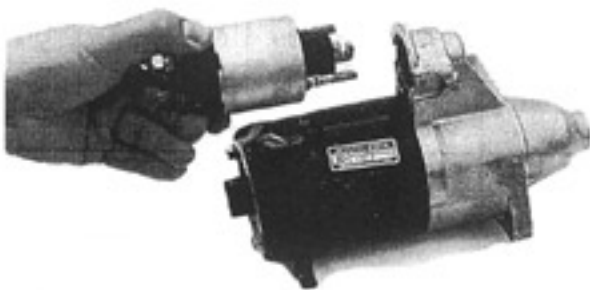

0302P152

Magnet Switch

1. Disconnect the connecting lead.
2. Remove the mounting nuts.
3. Remove the magnet switch by sliding it up so that it is disconnected from the drive lever.

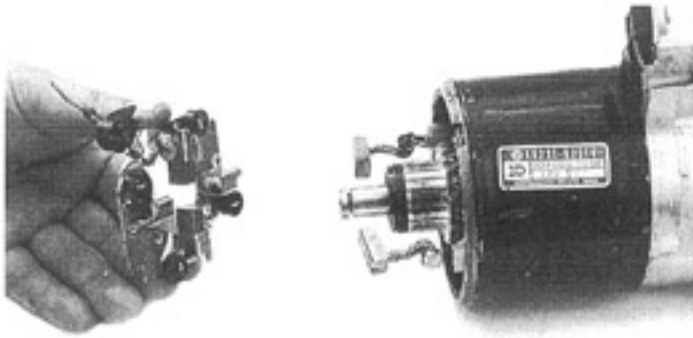
**Brush Holder**

1. Draw out the brush from the hold while holding the spring up.
2. Remove the brush holder.

(When reassembling)

- When replacing the spring, install it by referring to the figure.
- Do not contact the brush's positive lead with the body.

0302P155

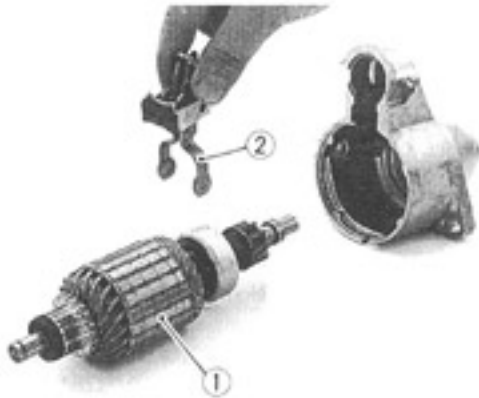
**Armature**

1. Draw out the armature (1) with the drive lever (2).

(When reassembling)

- Install the drive lever, noting its direction.

- (1) Armature
(2) Drive Lever

0302P157

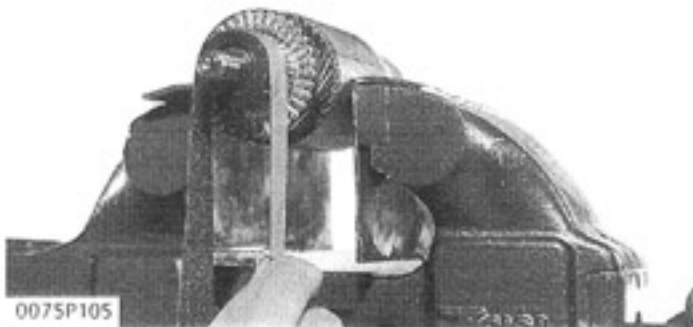
SERVICING**[1] STARTER**

0075P105

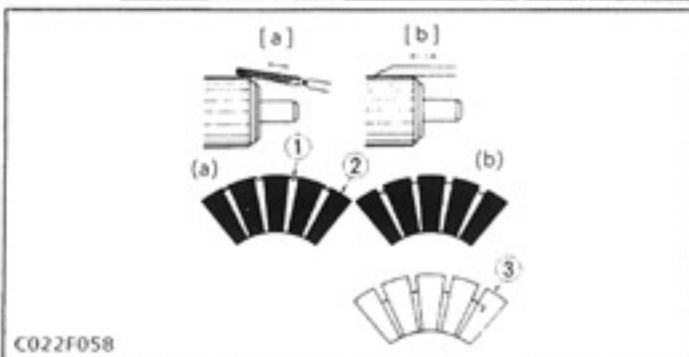

C022F058

Commutator and Mica

1. Check the contact face of the commutator for wear, and grind the commutator with sand paper if it is slightly worn.
2. Measure the commutator O.D. at several points.
3. If the difference of the O.D.'s exceeds the allowable limit, correct the commutator on a lathe to the factory specification.
4. If the minimum O.D. is less than the allowable limit, replace the armature.
5. Measure the mica undercut.
6. If the undercut is less than the allowable limit, correct with a saw blade and chamfer the segment edges.

- [a] Bad
[b] Good

- (1) Mica
(2) Segment
(3) Depth of Mica

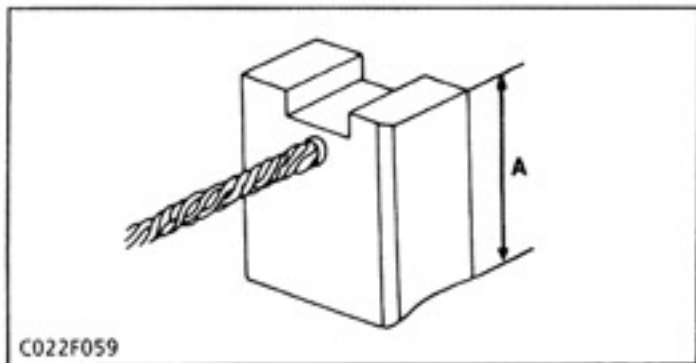
**Brush Wear**

1. Measure the brush length A.
2. If the length is less than the allowable limit, replace the brush.