

Wind Vane Service Manual

Document number: 83170-1
15 May 2004

Short arm E22078

Long arm E22079

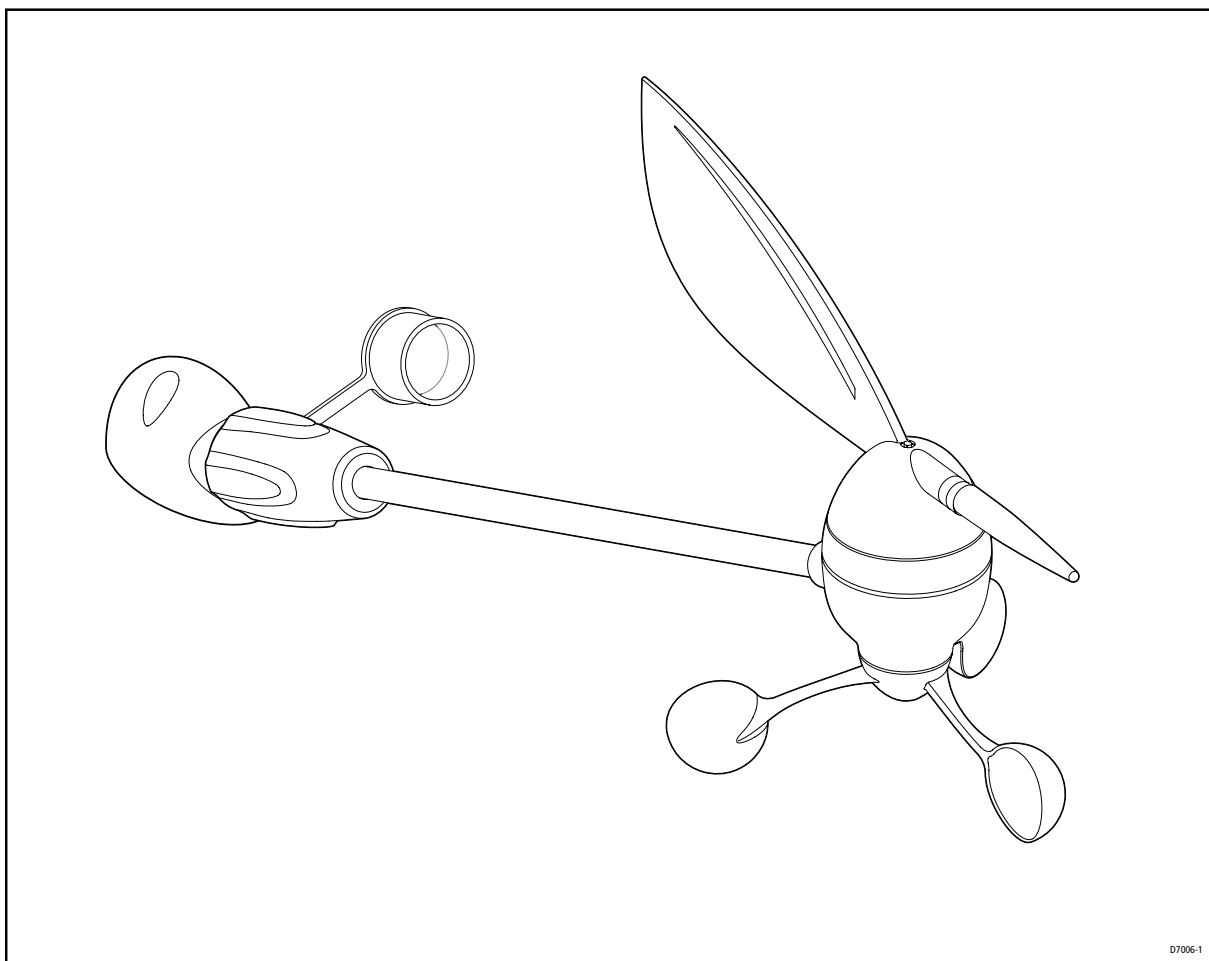

Raymarine

Wind Vane

Service Manual

Contents

Introduction	3
Safety	3
Overview	3
Tools & test equipment	3
Construction	4
Parts list	5
Disassembly	5
Transducer arm	5
Wind vane base	6
Reassembly	6
Wind vane base	6
Transducer arm	7
Testing	7
PCB	8
Circuit diagram	8
Layout diagram	9
Component List	9

Introduction

Safety

**WARNING: Product servicing**

The wind vane must be serviced in accordance with the Raymarine instructions provided. Failure to do so could result in poor product performance, personal injury and/or damage to the boat.

**WARNING: Electrical safety**

Always switch off the power supply before you work on Raymarine products.

**CAUTION: Electrostatic Discharge**

The wind vane contains electrostatic sensitive components. Always observe the appropriate precautions when handling, shipping, and storing these products. Failure to do this could result in permanent damage to the equipment.

Overview

This manual provides servicing information for the Raymarine short-arm and long-arm wind vanes, part numbers E22078 and E22079, respectively. The following information is provided:

- Tools and test equipment.
- An exploded view of the wind vane.
- A list of replaceable parts.
- Disassembly and assembly instructions.
- Functional tests.
- Wind vane PCB circuit, layout and parts.

Tools & test equipment

The following tools and test equipment are required:

- Two small Pozidriv screwdrivers.
- One small flat-blade screwdriver.
- Serviceable ST60 Wind instrument.
- 12 V power supply.
- Multimeter.

Construction

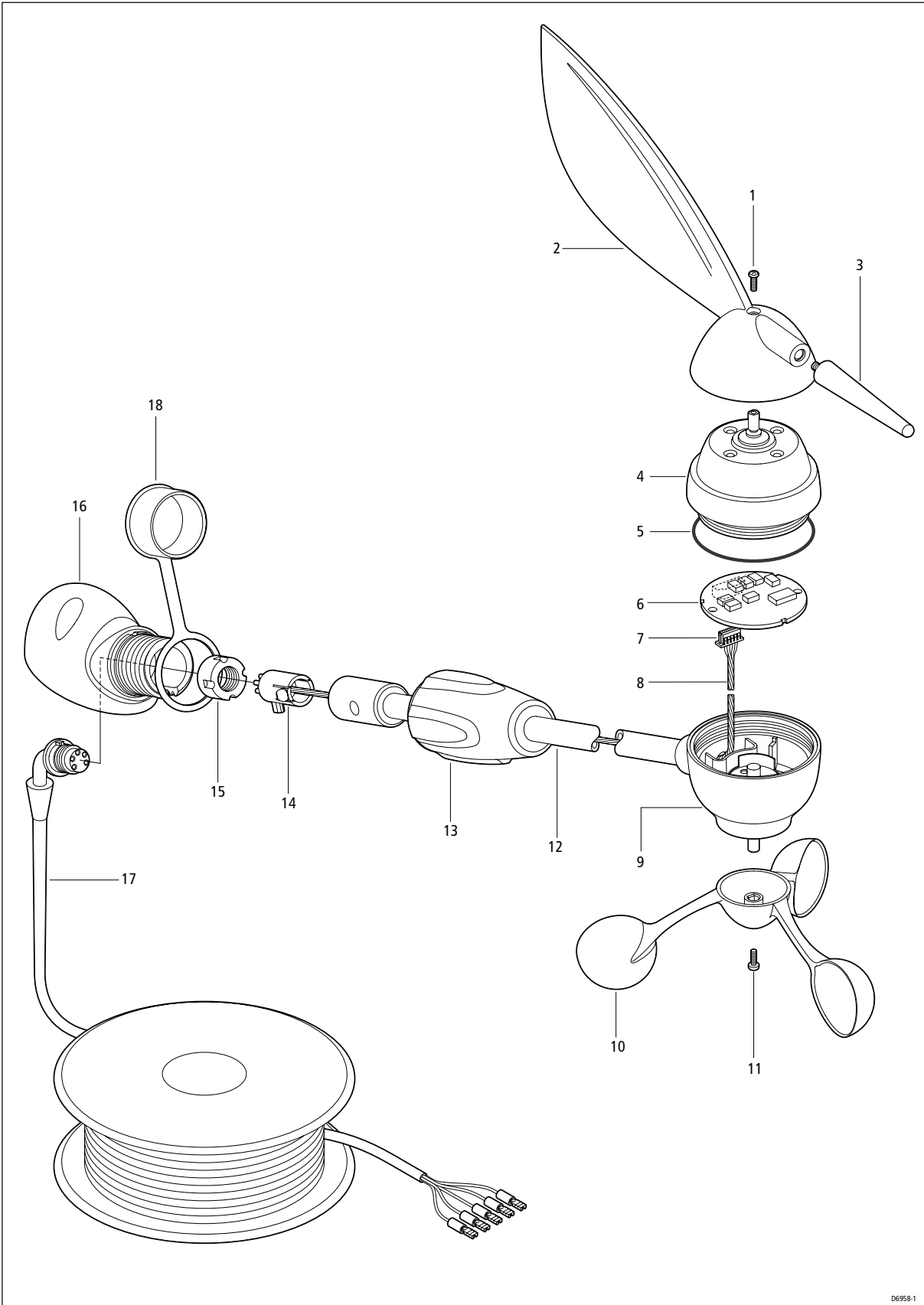

Figure 1: New Wind Vane exploded view

D6958-1

Parts list

The New Wind Vane parts are as follows:

Item	Description	Part No.
	Wind vane kit comprises:	A28167
1 & 11	Screws	
2	Vane	
3	Counterbalance weight	
10	Anemometer cups	
4	Top Pod includes: bearing magnet assembly	A28168
5	O-ring seal	
6	PCB assembly	A28164
	Transducer arm cable assembly: either 300 mm or 600 mm	A28165 A28166
	comprises:	
7	upper connector	
8	cable	
14	lower connector	
12	Transducer arm: either Short arm (300mm) or Long arm (600mm)	A28159 A28160
	includes fitted:	
9	bottom pod	
13	locking ring O-ring (not illustrated)	
16	Wind transducer base	A28161
	Cable and connector assembly: either 30m cable or 50m cable	A28162 A28163
	comprises:	
15	nut	
17	cable	
18	Connector cap	R28169

Disassembly

To dismantle the wind vane:

1. Unscrew the locking ring (item 13) that secures the transducer arm (item 12) to the wind vane base (item 16), then separate these two items.
2. Carry out the disassembly instructions for the transducer arm and wind vane base.

Transducer arm

To dismantle the transducer arm:

1. Remove and retain the screw (item 1) that secures the assembled wind vane (item 2) and balance weight (item 3) to the top pod (item 4) shaft, then pull the vane and balance weight from the shaft.
2. Remove and retain the screw (item 11) that secures the anemometer cups (item 10) to the bottom pod (item 9) shaft, then pull the cups from the shaft.
3. Unscrew the top and bottom pods from one another. If necessary, use a suitable tool to engage with the holes in the top pod, to facilitate this.
4. Remove the O-ring seal (item 5).
5. Referring to *Figure 2*, insert a suitable tool (e.g. small screwdriver) into the breakout holes at the edge of the PCB (item 6), then use the tool to GENTLY ease the PCB from its recess in the bottom pod.

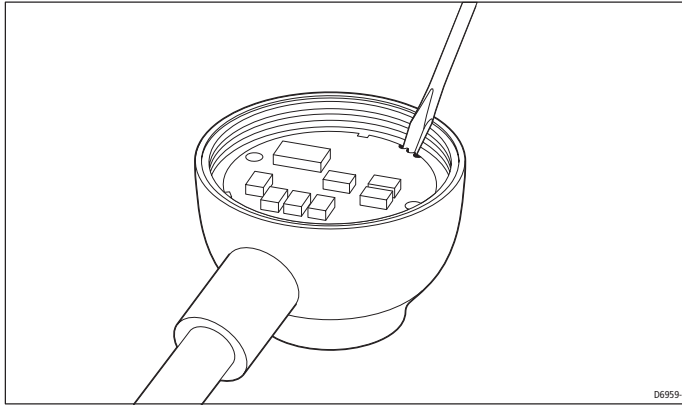

Figure 2: Easing out PCB

6. Separate the PCB from the bottom pod just sufficiently to gain access to the upper connector (item 7) on the transducer arm cable assembly, then disconnect the connector from the PCB.
7. At the lower end of the transducer arm, press in both clips to release the lower connector (item 14) from the transducer arm (see *Figure 3*).

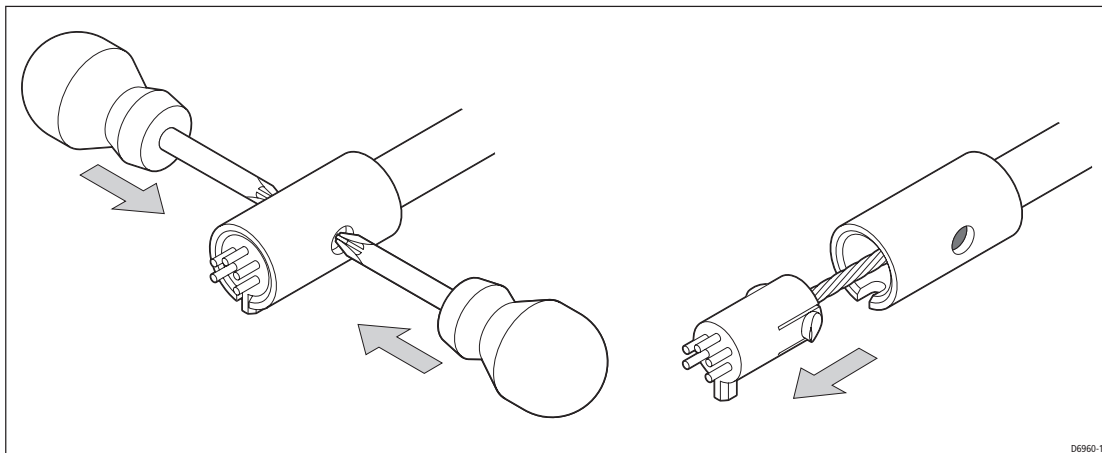

Figure 3: Releasing lower connector

8. Carefully guide the upper connector (item 7) on the transducer arm cable assembly, out of the bottom pod, then withdraw the complete transducer arm cable assembly through the bottom of the transducer arm.

Wind vane base

To dismantle the wind vane base (item 16):

1. Using a suitable tool, remove and retain the nut (item 15) that secures the cable connector in the wind vane base.
2. Withdraw the transducer cable and connector through the bottom of the wind vane base.

Reassembly

Wind vane base

To reassemble the wind vane base:

1. Ensuring that the key on the transducer cable connector engages with the respective keyway on the wind vane base, insert the connector through the bottom of the wind vane base into the correct position in the base.
2. Using a suitable tool, secure the connector in the base with the nut retained during disassembly. Tighten the nut until its front edge is flush with the upper face of the connector.

Transducer arm

To reassemble the transducer arm:

1. Fit the transducer arm cable assembly as follows:
 - i. Arrange the upper connector of the transducer arm cable assembly as shown in *Figure 4*.

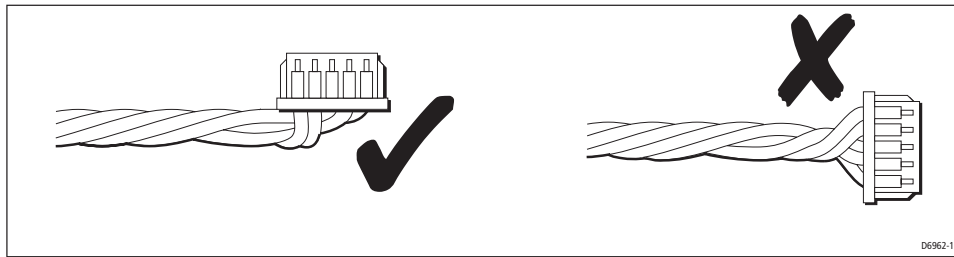

Figure 4: Cable/connector arrangement

- ii. Feed the transducer arm cable assembly upper connector through the bottom of the arm, then up the arm and into the bottom pod.
 - iii. Ensuring that the key on the lower connector of the transducer arm cable assembly is aligned with the keyway on the arm, push the lower connector into the bottom of the arm, until both clips engage, to secure the connector in the arm.
 - iv. Connect the upper connector of the transducer arm cable assembly to the appropriate connector on the PCB.
2. With the PCB connector adjacent to the cable entry hole on the top pod, place the PCB in its recess in the bottom pod, ensuring that the cut-aways in the PCB engage with the respective protrusions on the lower pod.
3. Check the condition of the O-ring seal (item 5) and if it has been damaged, obtain a new one.
4. Fit the O-ring seal into the groove above the thread on the top pod.
5. Screw the top and bottom pods together and secure tightly, to ensure a waterproof seal. If necessary, use a suitable tool to engage with the holes in the top pod, to facilitate this.
6. Ensuring that the flats on the anemometer cups and the lower pod shaft are aligned, slide the anemometer cups on to the lower pod shaft then secure with the screw removed during disassembly.
7. Ensuring that the flats on the vane and the upper pod shaft are aligned, slide the vane to the upper pod shaft then secure with the screw removed during disassembly.

Testing

To check that a wind vane is serviceable:

1. Connect the wind vane to a serviceable ST60 Wind instrument as in *Figure 5*.

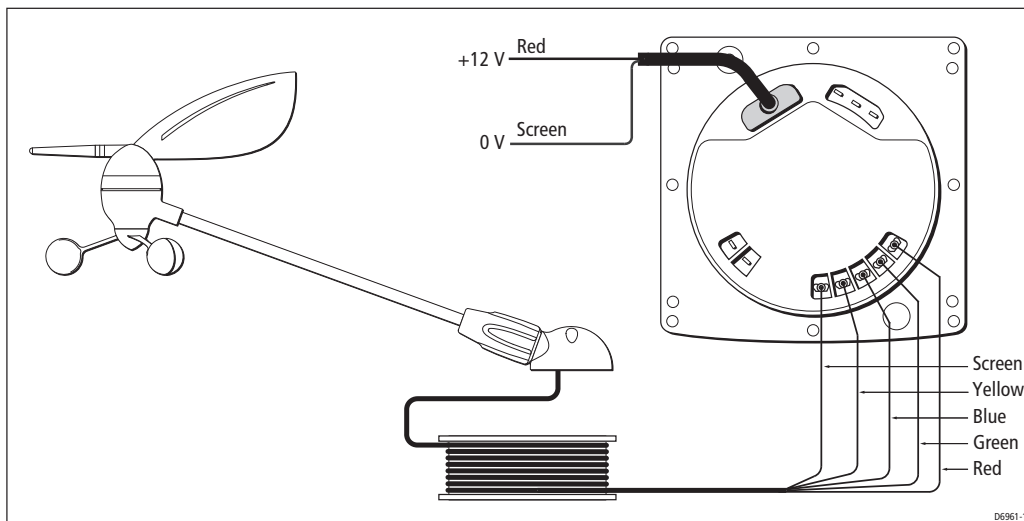

Figure 5: Test connections

2. At the ST60 Wind instrument, check that the voltage between the red and black connections is 8 V dc, ± 0.25 V:
3. Rotate the vane to the forward, starboard, aft and port orientations in turn and, at the instrument, check the sine and cosine signals by measuring the voltages as follows:

Vane direction	Voltage between Blue & Black (sine signal)	Voltage between Green & Black (cosine signal)
Pointing forward	Half the supply voltage measured at step 2.	Half the supply voltage as measured at step 2 plus at least 1 V but not more than 2 V.
Pointing to starboard	Half the supply voltage as measured at step 2 plus at least 1 V but not more than 2 V.	Half the supply voltage measured at step 2.
Pointing aft	Half the supply voltage measured at step 2.	Half the supply voltage as measured at step 2 minus at least 1 V but not more than 2 V.
Pointing to port	Half the supply voltage as measured at step 2 minus at least 1 V but not more than 2 V.	Half the supply voltage measured at step 2.

4. SLOWLY rotate the anemometer cups and check that the voltage between the yellow and black connections switches between approximately 8 V and 3.2 V, twice during each rotation.

PCB

Circuit diagram

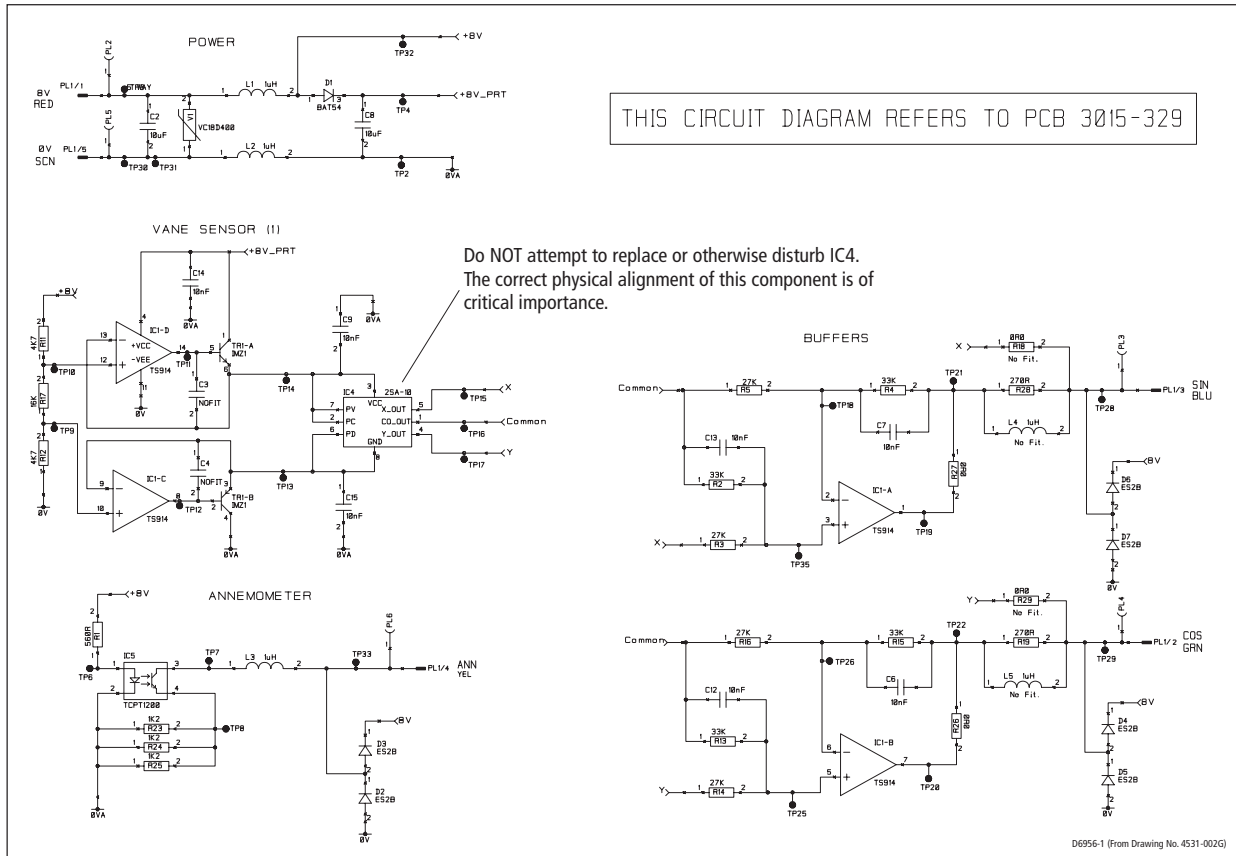

Reference	Part No.	Description
R2	91AAAXX33K	RESISTOR 33K,0.063W,0603
R3	91AAAXX27K	RESISTOR 27K 1% 0.063W
R4	91AAAXX33K	RESISTOR 33K,0.063W,0603
R5	91AAAXX27K	RESISTOR 27K 1% 0.063W
R11	91AAAXX4K7	RESISTOR 4.7K,1% 0.063W 0603
R12	91AAAXX4K7	RESISTOR 4.7K,1% 0.063W 0603
R13	91AAAXX33K	RESISTOR 33K,0.063W,0603
R14	91AAAXX27K	RESISTOR 27K 1% 0.063W
R15	91AAAXX33K	RESISTOR 33K,0.063W,0603
R16	91AAAXX27K	RESISTOR 27K 1% 0.063W
R17	91AAAXX16K	RESISTOR 16K,1%,0.063W, 0603
R19	91AAAXX270R	RES. 270R, 1%, 0.063W, 0603
R23	91AAAXX1K2	RESISTOR - 1K2 1% 0603
R24	91AAAXX1K2	RESISTOR - 1K2 1% 0603
R25	91AAAXX1K2	RESISTOR - 1K2 1% 0603
R26	91010R0	ZERO OHM LINK, 0603 PACKAGE
R27	91010R0	ZERO OHM LINK, 0603 PACKAGE
R28	91AAAXX270R	RES. 270R, 1%, 0.063W, 0603
TR1	9500IMZ1	DUAL TRANSISTOR ARRAY
V1	9108VC180400	TRANSIENT VOLTAGE SUPPRESSOR