

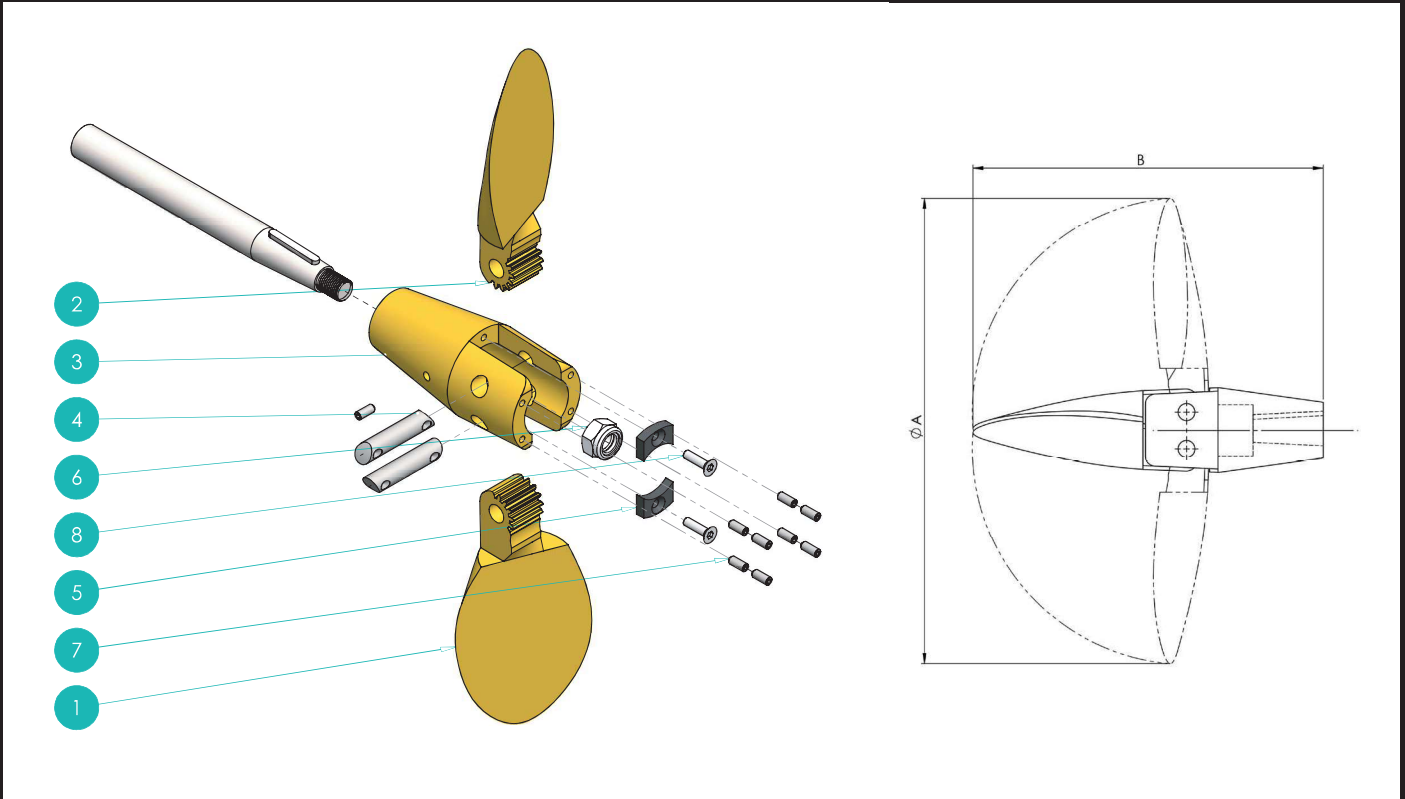

# FHBC RACING

## Folding propeller



N°	DESIGNATION	MATIERE / MATERIAL	QTY
1	PALE FEMELLE / Female blade	Cupro-Aluminium / Ni-Br-Al	1
2	PALE MALE / Male blade	Cupro-Aluminium / Ni-Br-Al	1
3	MOYEU / Hub	Cupro-Aluminium / Ni-Br-Al	1
4	AXE / Axis	Inox 316L / Stainless steel 316L	2
5	CALE / Wedge	P.O.M	2
6	ECROU / Nut	Inox / Stainless Steel	1
7	VIS POINTEAU / Threaded pin	Inox / Stainless Steel	9
8	VIS M5 / Screw M5	Inox / Stainless Steel	2

HÉLICE / PROPELLER	MOYEU / HUB	ØA	B	POIDS / WEIGHT
15 "	Ø22 mm	381 mm	281 mm	4.8 kg
	Ø25 mm	381 mm	289 mm	4.9 kg
	Ø30 mm	381 mm	307 mm	5.3 kg
	Sail Drive	381 mm	305 mm	6.4 kg
16 "	Ø22 mm	406 mm	294 mm	5 kg
	Ø25 mm	406 mm	302 mm	5.1 kg
	Ø30 mm	406 mm	320 mm	5.5 kg
	Sail Drive	406 mm	318 mm	6.7 kg
17 "	Ø22 mm	432 mm	307 mm	5.2 kg
	Ø25 mm	432 mm	315 mm	5.3 kg
	Ø30 mm	432 mm	333 mm	5.7 kg
	Sail Drive	432 mm	331 mm	6.8 kg
18 "	Ø22 mm	457 mm	320 mm	5.4 kg
	Ø25 mm	457 mm	328 mm	5.5 kg
	Ø30 mm	457 mm	346 mm	5.9 kg
	Sail Drive	457 mm	344 mm	7.1 kg

Les valeurs sont données à titre indicatif. FRANCE HELICES se réserve le droit de les modifier sans préavis.  
The values are given for information only. FRANCE HELICES reserves the right to amend them without prior notice.