



# Heavy-Duty Alternators

## 23HD and 24HD Series Troubleshooting Guide

### **HD Power Solutions, Inc.**

5083 Martin Luther King Jr Freeway - Fort Worth, TX 76119

Phone: (800) 443-9394 - Fax: (682) 301-1798 - Website: [www.hdpsi.com](http://www.hdpsi.com)



*Power that keeps the world moving!*

# INDEX

**Page 1**

Configuration Alternators, Regulators and Wiring Harness

**Page 2**

On Vehicle TroubleShooting Guide

**Page 3**

Alternator Electrical Condition

**Page 4**

23/24HD Series Terminal Identification

**Page 5 - 7**

Regulator Identification and Pin Function

**Page 8**

23HD Series Alternator Terminal Identification

**Page 9**

24HD Series Alternator Terminal Identification

**Page 10**

Isolator Terminal Identification and Terminal Connections

**Page 11 - 13**

23HD Series Alternator to Regulator Connections

**Page 14 - 16**

24HD Series Alternator to Regulator Connections

**Page 17 - 19**

Alternator and Regulator Voltage Test, 23/24HD Series Alternators

**Page 20**

How to Full Field 23/24HD Series Alternators

**Page 21**

How to Test for AMP Load

**Page 22**

Bench Test Procedures

**Page 23**

Isolator Test

**Page 24**

Finding Pulley Ratio

**Page 25**

Recommend Battery Cable Size

**Page 26**

23HD Series Power Curves

**Page 27 - 29**

24HD Series Power Curves

**Page 30**

Miscellaneous Alternator Information

**Page 31**

24HD Series 24-Volt Voltage Test

## Wiring Harness and Regulator CONFIGURATION

All 23HD Series Standard Alternators:

120 Amp, 14-Volt Models

---

All 24HD Series Standard Alternators:

160 Amp, 14-Volt Models

190 Amp, 14-Volt Models

220 Amp, 14-Volt Models

---

### Wiring Harness Color and Configuration

#1 (S2)	Auxiliary Sense Lead - <b>Red w/Yellow stripe</b>
#2 (F)	Field Lead - <b>Blue</b>
#3 (I)	Ignition Lead - <b>Brown or Green w/ Red stripe</b>
#4 (S1)	Sense Main Battery Lead - <b>Red w/ White stripe</b>
#5 (Grd)	Ground Lead - <b>Black</b>
#6 (S)	Stator Lead - <b>White</b>
#7 (A)	Current Power Lead - <b>Red</b>

---

### 10-199 L.E.D. Configuration

**Green** LED on Indicates the A Terminal has battery power

**Yellow** LED on Indicates Field is on and supplying field current

**Orange** LED on Indicates Stator output is present Alternator is working

**Red** LED on Indicates Overload condition, Low voltage condition

**ON VEHICLE TROUBLESHOOTING GUIDE**  
**PRELIMINARY PROCEDURES**  
(23HD and 24HD SERIES ALTERNATORS)  
**ALL MODELS WITH *EXTERNAL REGULATORS***

- 1) CHECK ALTERNATOR DRIVE BELT (S) AND BELT TENSION.
- 2) CHECK ALTERNATOR POSITIVE AND NEGATIVE CABLE CONNECTIONS.
- 3) CHECK FOR PROPERLY SIZED CABLES FROM ALTERNATOR TO BATTERY (S), BOTH POSITIVE AND NEGATIVE. **0 CABLE MINIMUM.**
- 4) CHECK NEGATIVE CABLE CONNECTIONS TO FRAME RAILS WHEN USED FOR GROUND CIRCUIT, FOR CLEAN TIGHT CONNECTIONS. **0 CABLE MINIMUM.**
- 5) CHECK CABLE CONNECTIONS **ON** BATTERY FOR CLEAN TIGHT CONNECTIONS.
- 6) CHECK BATTERY (S) CONDITION, 12.6 VOLT – 100%, 12.4 VOLT – 75%, 12.2 VOLT – 50% STATE OF CHARGE. TRUE BATTERY VOLTAGE IS OBTAINED **AFTER** REMOVING ANY SURFACE CHARGE FROM BATTERIES. IF BATTERY VOLTAGE IS **LESS THAN 12.4 VOLTS**, REPLACE OR RECHARGE BATTERIES AND RETEST. IF BATTERY VOLTAGE IS **EQUAL TO OR HIGHER THAN 12.4 VOLTS**, CONTINUE TO TEST.
- 7) IDENTIFY MODEL OF ALTERNATOR.
- 8) IDENTIFY MODEL OF REGULATOR.
- 9) DETERMINE IF VEHICLE IS ISOLATOR EQUIPPED.
- 10) LOCATE IN MANUAL THE CORRECT TERMINAL REFERENCE DRAWING FOR THE ALTERNATOR ON VEHICLE.
- 11) LOCATE IN MANUAL THE CORRECT TERMINAL CONNECTION REFERENCE DRAWING FOR THE ALTERNATOR AND REGULATOR ON VEHICLE.

## **ALTERNATOR ELECTRICAL CONDITION (POSSIBLE CAUSES)**

### LOW VOLTAGE OUTPUT

- 1) LOOSE DRIVE BELTS (S)
- 2) WIRING PROBLEM ON POSITIVE OR NEGATIVE OR BOTH CABLES. POOR CONNECTIONS OR IMPROPERLY SIZED WIRE FOR THE ALTERNATOR SIZE OR LENGTH OF CABLES.
- 3) CURRENT LOAD ON SYSTEMS GREATER THAN ALTERNATOR CAN PRODUCE AT THAT SPEED
- 4) WRONG PULLEY RATIO (P.R.) FOR APPLICATIONS: THE O.D. OF CRANKSHAFT PULLEY DIVIDED BY THE O.D. OF ALTERNATOR PULLEY DETERMINES P.R. MOST HEAVY DUTY APPLICATIONS REQUIRE A P.R. OF 2.5 OR HIGHER.
- 5) LOW REGULATOR SET POINT
- 6) DEFECTIVE REGULATOR
- 7) DEFECTIVE ALTERNATOR

### HIGH VOLTAGE OUTPUT

- 1) HIGH REGULATOR SET POINT
- 2) S1 SENSE TERMINAL CONNECTED AT WRONG POINT, BAD CONNECTION, OR NOT SENSING TRUE BATTERY VOLTAGE.
- 3) DEFECTIVE ISOLATOR (IF IN SYSTEM)
- 4) DEFECTIVE REGULATOR, OR REGULATOR ADJUSTMENT SET TOO HIGH.
- 5) RADIO FREQUENCY INTERFERENCE (RFI). IF HIGH VOLTAGE IS AN INTERMITTENT CONDITION CAN YOU TIE IT TO USING A POWERFUL RADIO? IF YES, CALL 1-800-443-9394 FOR TECHNICAL ASSISTANCE.

### NO VOLTAGE OUTPUT

- 1) NO DRIVE BELT
- 2) NO VOLTAGE ON "A" TERMINAL (BLOWN FUSE ON "A" LEAD) (10-130 REGULATOR: BLOWN FUSE ON REGULATOR)
- 3) NO VOLTAGE AT IGNITION TERMINAL
- 4) NO GROUND CABLE ON ISOLATED GROUND SYSTEM
- 5) FIELD CONNECTION NOT CORRECT ON INSULATED FIELD MODELS
- 6) DEFECTIVE REGULATOR: DO ON VEHICLE VOLTAGE TESTS. (See Pages 30-32)
- 7) DEFECTIVE ALTERNATOR: MOMENTARILY FULL FIELDING OF ALTERNATOR WILL DETERMINE IF IT IS GOOD OR BAD. (See Page 33)
- 8) REGULATOR GROUND LEAD HAS A BAD CONNECTION
- 9) S1 OR S2 NO VOLTAGE: CHECK FOR BLOWN FUSE OR BAD CONNECTION (10-170 REGULATOR: BLOWN FUSE)
- 10) F TERMINAL NO VOLTAGE: CHECK FOR BLOWN FUSE IN "A" TERMINAL LEAD

## **TERMINAL IDENTIFICATION**

### **23HD and 24HD Series Alternator**

#### **TERMINAL**

- A. Positive Alternator output Terminal
- B. Negative Alternator output Terminal of Ground connections
- C. Field Positive Terminal
- D. Stator of Relay Terminal (Tachometer connection)
  
- H. Battery Positive Terminal
- I. Battery Negative Terminal

#### **REGULATOR TERMINAL IDENTIFICATION**

- 1. (S2) Remote sense for Auxiliary Battery (Use only with isolator in system)
- 2. (F) FIELD: Regulator output (Drives field winding)
- 3. (I) IGNITION: Turns Regulator on (3,4,6 or 7 wire hook up)
- 4. (S1) Remote sense for the main battery
- 5. (Grd) Circuit grounding for the regulator
- 6. (S) STATOR: 3 or 6 wire hook up turns regulator on  
(S) 4 or 7 wire hook up turn charge light off
- 7. (A) BATTERY POSITIVE: Power supply to regulator and field

#### **ISOLATOR TERMINAL IDENTIFICATION**

- P. B1 Main Battery Connection
- Q. A Alternator Connection
- R. B2 Auxiliary Battery Connection
- S. Auxiliary Battery Positive Post
- T. Auxiliary Battery Negative Post

## REGULATOR PIN IDENTIFICATION

(MODEL 10-11)

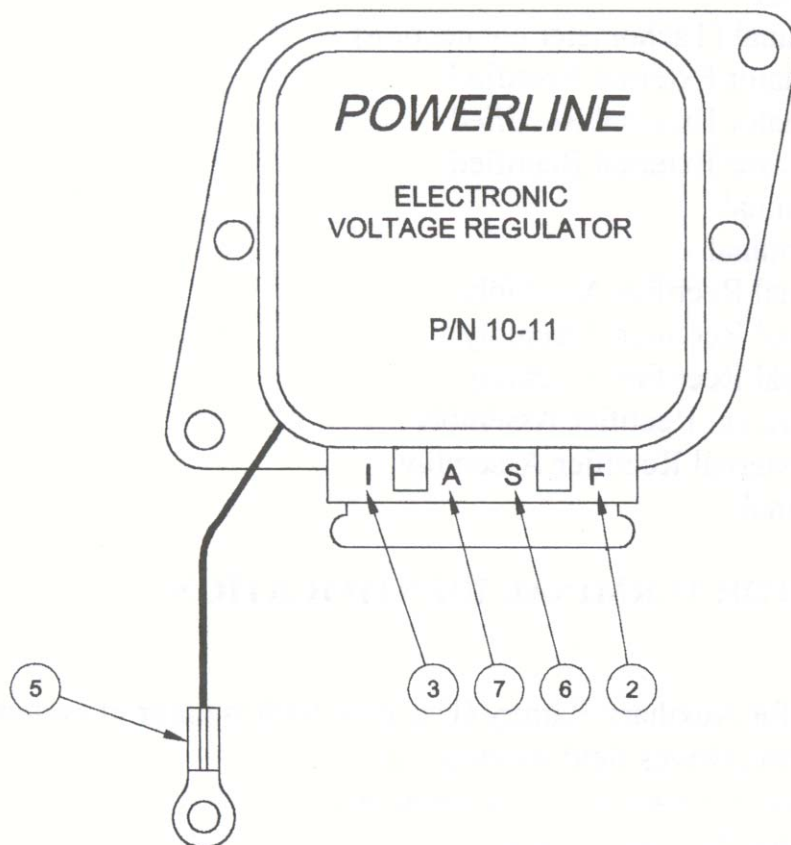

### PIN FUNCTION

- |    |      |  |
|----|------|--|
| 2. | F    | REGULATOR OUTPUT (DRIVES FIELD WINDING OF  |
| 3. | I    | ALTERNATOR) TURNS REGULATOR ON (4 WIRE HOOK-UP)  |
| 5. | CASE | CIRCUIT GROUND FOR REGULATOR   |
| 6. | S    | 3 WIRE HOOK-UP (TURNS REGULATOR ON)<br>4 WIRE HOOK-UP (TURNS WARNING LIGHT OFF WHEN THE ALTERNATOR IS WORKING) |
| 7. | A    | POWER SUPPLY AND VOLTAGE SENSE LEAD FOR REGULATOR (ALL MODELS)   |

## REGULATOR PIN IDENTIFICATION

(MODEL 10-129 & 10-130)

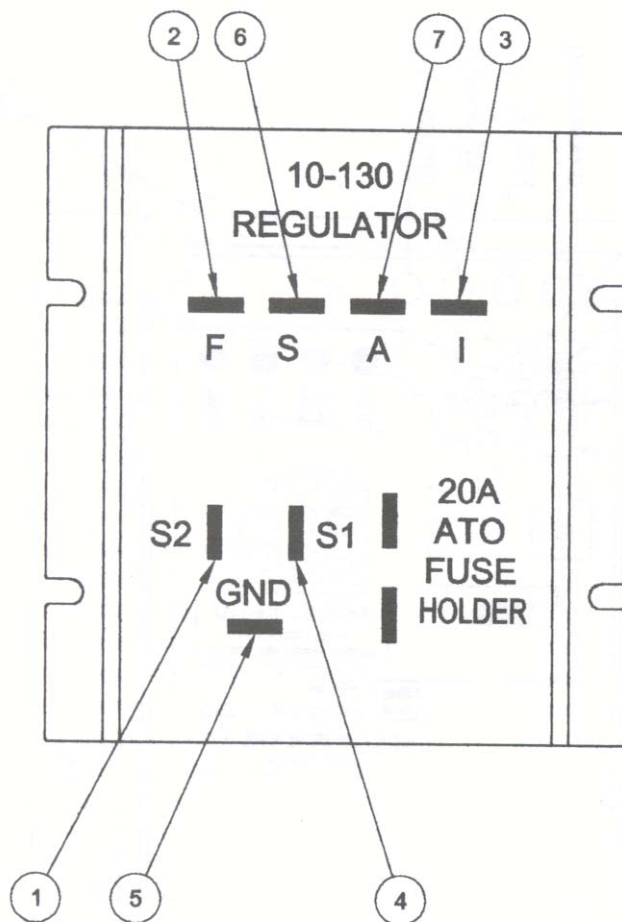

### PIN FUNCTION

- |    |     |  |
|----|-----|--|
| 1. | S2  | REMOTE SENSE FOR AUXILIARY BATTERY   |
| 2. | F   | REGULATOR OUTPUT (DRIVES FIELD WINDING OF ALTERNATOR)  |
| 3. | I   | TURNS REGULATOR ON (4 WIRE HOOK-UP)  |
| 4. | S1  | REMOTE SENSE FOR THE MAIN BATTERY  |
| 5. | GND | CIRCUIT GROUND FOR THE REGULATOR   |
| 6. | S   | 6 WIRE HOOK-UP (TURNS THE REGULATOR ON)<br>7 WIRE HOOK-UP (TURNS THE WARNING LIGHT OFF WHEN THE ALTERNATOR IS WORKING) |
| 7. | A   | POWER SUPPLY TO THE REGULATOR AND FIELD  |



## REGULATOR PIN IDENTIFICATION

(MODEL 10-170 & 10-172)

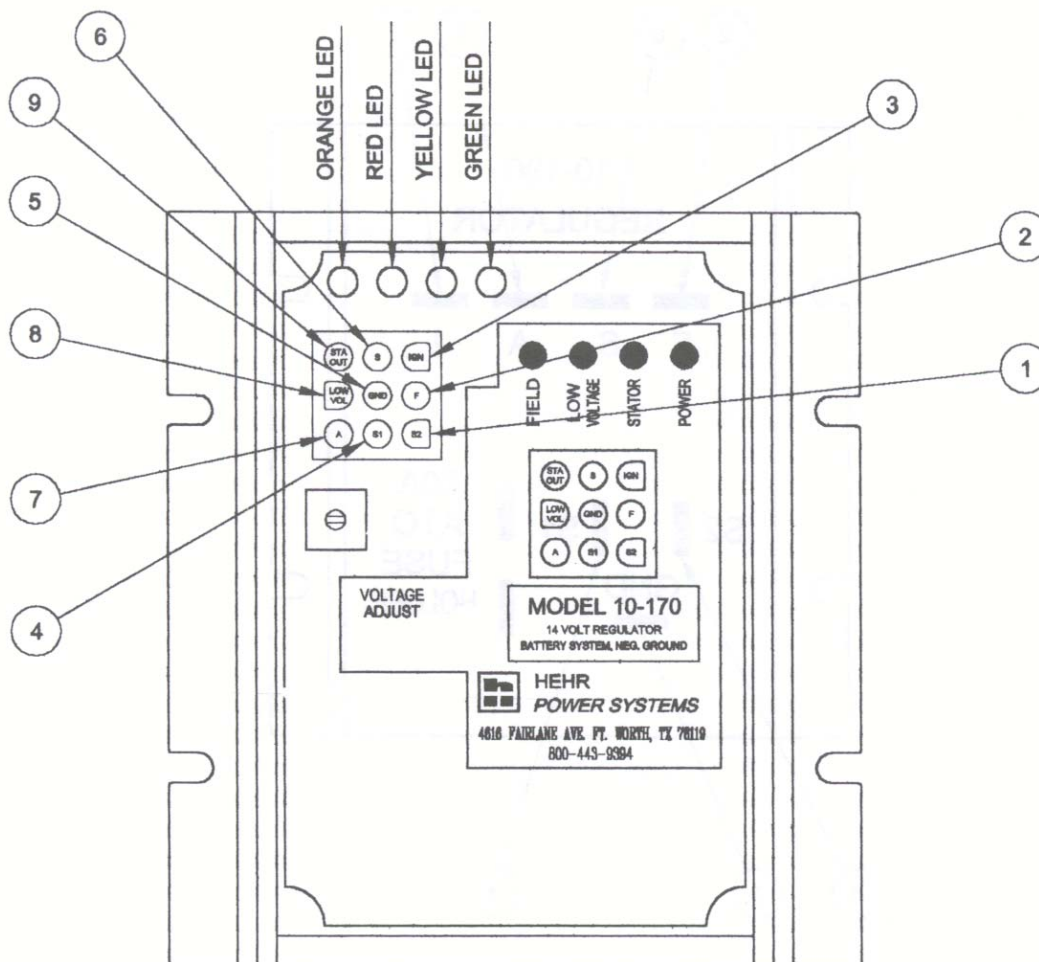

### PIN FUNCTION

- |    |     |   |
|----|-----|---|
| 1. | S2  | REMOTE SENSE FOR AUXILIARY BATTERY                                  |
| 2. | F   | REGULATOR OUTPUT (DRIVES FIELD WINDING)                             |
| 3. | I   | TURNS REGULATOR ON (4 WIRE HOOK-UP)                                 |
| 4. | S1  | REMOTE SENSE FOR THE MAIN BATTERY                                   |
| 5. | GND | CIRCUIT GROUND FOR THE REGULATOR                                    |
| 6. | S   | 7 WIRE HOOK-UP (TURNS WARNING LIGHT OFF WHEN ALTERNATOR IS WORKING) |
| 7. | A   | POWER SUPPLY TO THE REGULATOR AND FIELD                             |
| 8. |     | LOW VOLTAGE (REMOTE LED)  |
| 9. |     | STATOR ON (REMOTE LED)  |

**23HD SERIES**  
(14 VOLT 120 AMP)

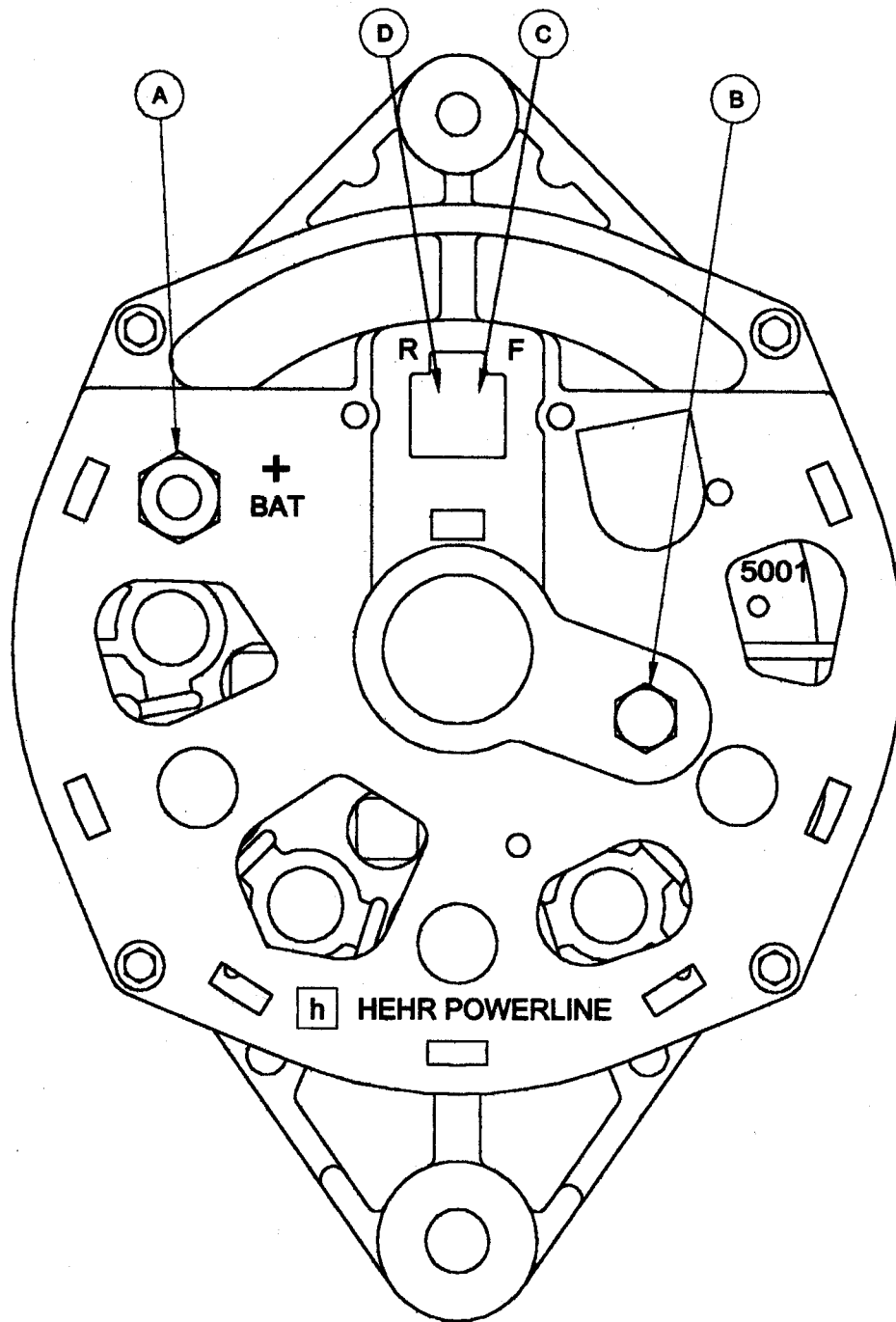

**TERMINAL IDENTIFICATION**

- A. POSITIVE OUTPUT TERMINAL
- B. GROUND
- C. FIELD
- D. RELAY (R) STATOR TERMINAL

**24HD SERIES**

(14 VOLT, 160, 190 &amp; 220 AMP)

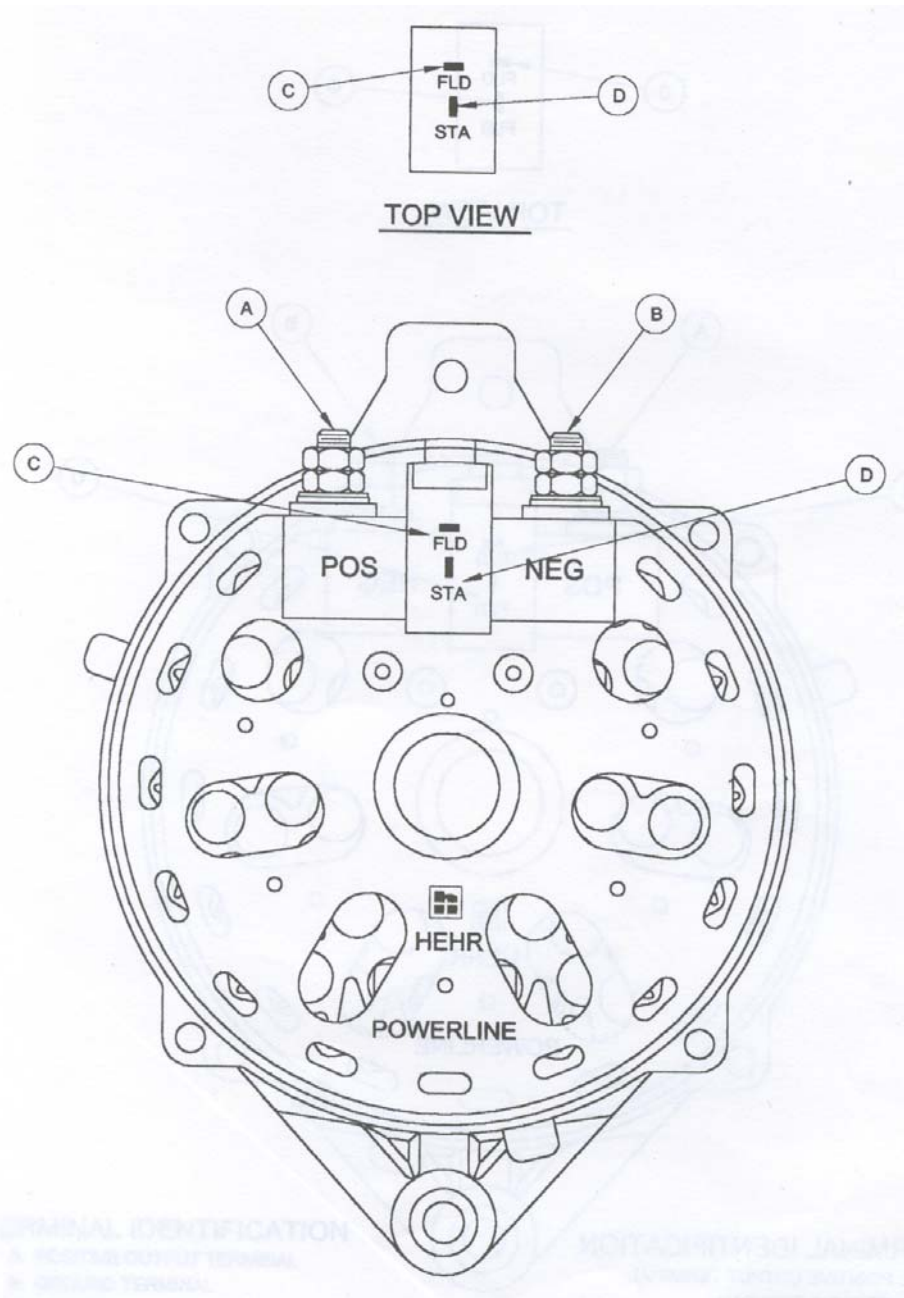
**TERMINAL IDENTIFICATION**

- A. POSITIVE OUTPUT TERMINAL
- B. GROUND TERMINAL
- C. STATOR TERMINAL
- D. FIELD TERMINAL

## ISOLATOR

(TERMINAL IDENTIFICATION AND CONNECTIONS)

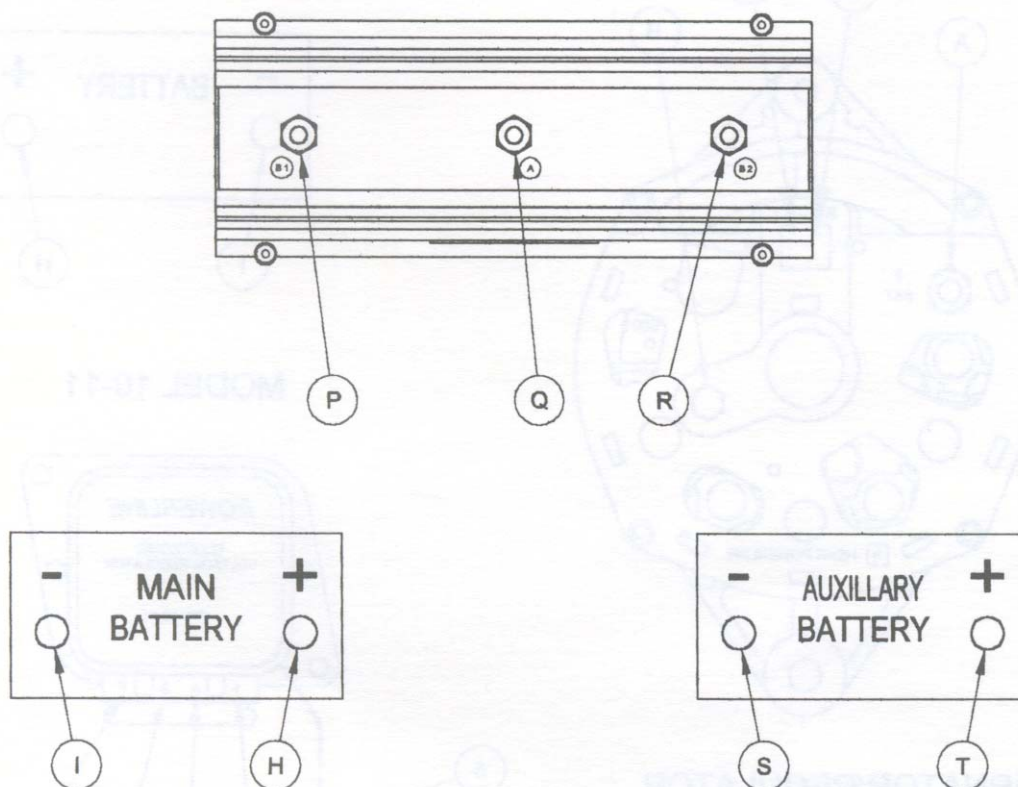

### TERMINAL IDENTIFICATION

- H. MAIN BATTERY POSITIVE POST
- I. MAIN BATTERY NEGATIVE POST
- P. MAIN BATTERY POSITIVE POST CONNECTION
- Q. ALTERNATOR INPUT POST
- R. AUXILIARY BATTERY POST POSITIVE CONNECTION
- S. AUXILIARY BATTERY NEGATIVE POST
- T. AUXILIARY BATTERY POSITIVE POST

### TERMINAL CONNECTIONS

- H. CONNECTS TO P
- I. CONNECTS TO GROUND
- P. CONNECTS TO H
- Q. CONNECTS TO A ON ALTERNATORS
- R. CONNECTS TO T
- S. CONNECTS TO GROUND
- T. CONNECTS TO R

## 23HD SERIES: WIRING CONNECTIONS

(14 VOLT, 120 AMP)

EXTERNAL REGULATOR: 10-11

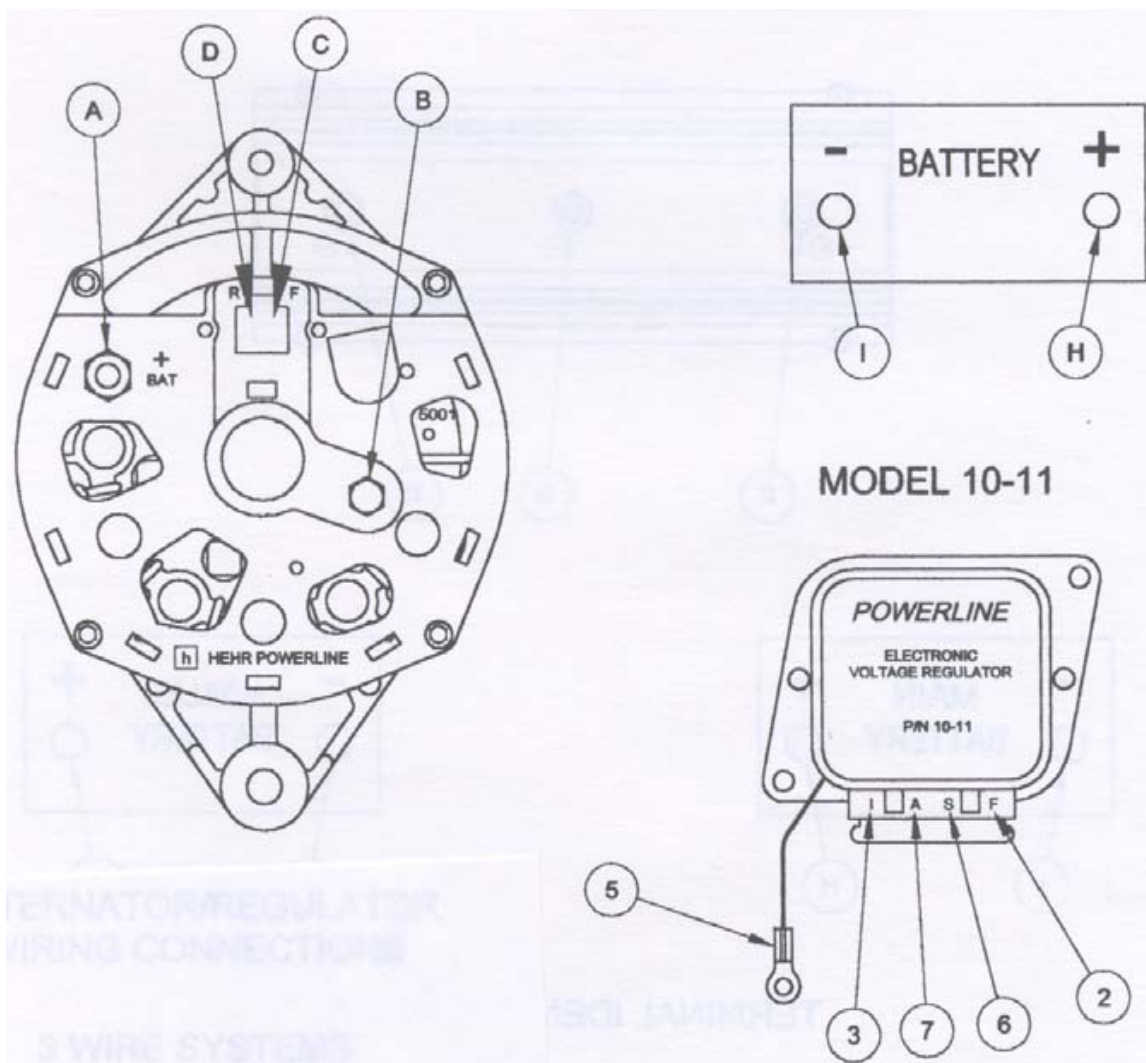

### 3 WIRE SYSTEMS

- A. CONNECTS TO H
- B. CONNECTS TO I
- C. CONNECTS TO #2
- D. NOT USED (TACHOMETER CONNECTION)
- 3. NOT USED
- 5. CONNECTS TO A GOOD GROUND CONNECTION
- 6. CONNECTS TO ON/OFF IGNITION
- 7. CONNECTS TO H

### 4 WIRE SYSTEMS

- A. CONNECTS TO H
- B. CONNECTS TO I
- C. CONNECTS TO #2
- D. CONNECTS TO #6 (ALSO TACHOMETER CONNECTION)
- 3. CONNECTS TO ON/OFF IGNITION THRU CHARGE LIGHT
- 5. CONNECTS TO A GOOD GROUND CONNECTION
- 7. CONNECTS TO H

### REGULATOR PIN FUNCTION

- 2. F REGULATOR OUTPUT (DRIVES FIELD WINDING OF ALTERNATOR)
- 3. I TURNS REGULATOR ON (4 WIRE HOOK-UP)
- 5. CASE CIRCUIT GROUND FOR REGULATOR
- 6. S 3 WIRE HOOK-UP (TURNS REGULATOR ON)  
4 WIRE HOOK-UP (TURNS WARNING LIGHT OFF WHEN ALTERNATOR IS WORKING)
- 7. A POWER SUPPLY AND VOLTAGE SENSE LEAD FOR REGULATORS (ALL MODELS)

## 23HD SERIES: WIRING CONNECTIONS

(12 VOLT 120 AMP)

EXTERNAL REGULATOR: 10-130

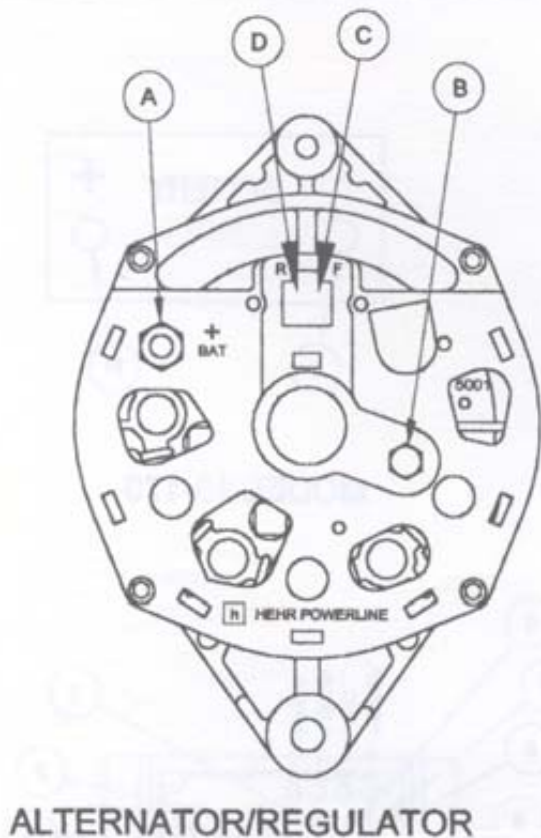

ALTERNATOR/REGULATOR

### 6 WIRE SYSTEMS

- A. CONNECTS TO H
- B. CONNECTS TO I
- C. CONNECTS TO #2
- D. NOT USED (TACHOMETER CONNECTION)
  - 1. CONNECTS TO AUXILIARY BATTERY (WHEN USED)
  - 2. CONNECTS TO C
  - 3. NOT USED
  - 4. CONNECTS TO H
  - 5. CONNECTS TO B
  - 6. CONNECTS TO ON/OFF IGNITION
  - 7. CONNECTS TO H

### 7 WIRE SYSTEMS

- A. CONNECTS TO H
- B. CONNECTS TO I
- C. CONNECTS TO #2
- D. CONNECTS TO #6
  - 1. CONNECTS TO AUXILIARY BATTERY (WHEN USED)
  - 2. CONNECTS TO C
  - 3. CONNECTS TO ON/OFF IGNITION THRU CHARGE LIGHT
  - 4. CONNECTS TO H
  - 5. CONNECTS TO B
  - 6. CONNECTS TO D
  - 7. CONNECTS TO H

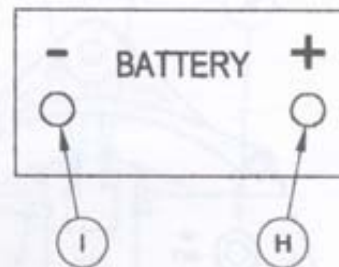

MODEL 10-130

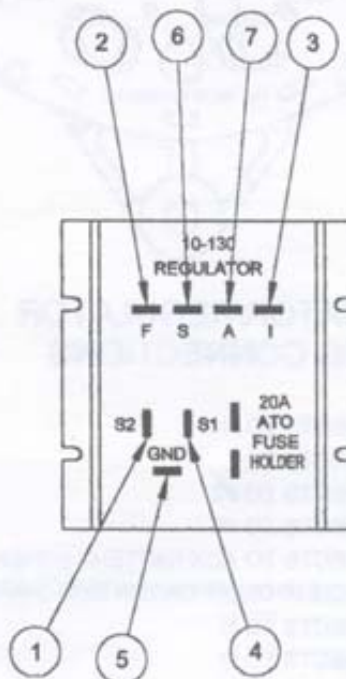

### REGULATOR PIN FUNCTION

- 1. S2 REMOTE SENSE FOR THE AUXILIARY BATTERY
- 2. F REGULATOR OUTPUT (DRIVES FIELD WINDING)
- 3. I TURNS REGULATOR ON (4 WIRE HOOK-UP)
- 4. S1 REMOTE SENSE FOR THE MAIN BATTERY
- 5. GND CIRCUIT GROUNDING FOR THE MAIN BATTERY
- 6. S 6 WIRE HOOK-UP (TURNS REGULATOR ON)  
7 WIRE HOOK-UP (TURNS WARNING LIGHT OFF WHEN ALTERNATOR IS WORKING)
- 7. A POWER SUPPLY TO REGULATOR AND FIELD

## 23HD SERIES: WIRING CONNECTIONS

(14 VOLT, 120 AMP)

EXTERNAL REGULATOR: 10-170 & 10-172

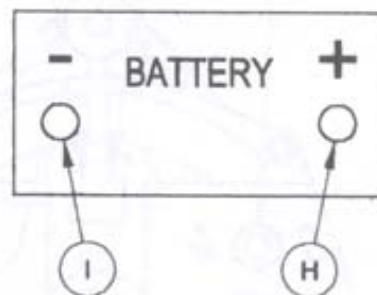
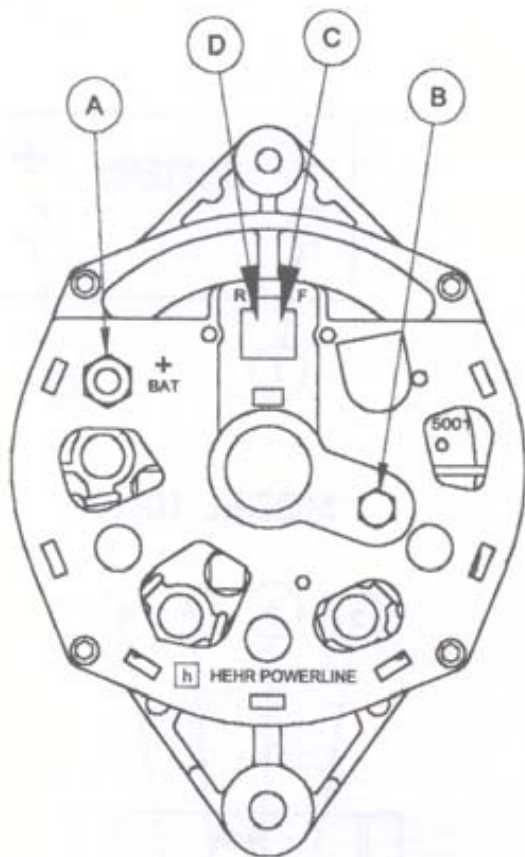

MODEL 10-170

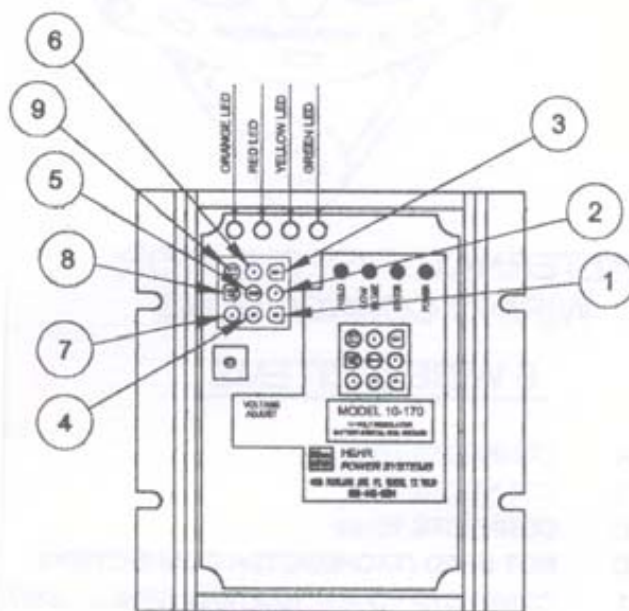

### 6/7 WIRE SYSTEM

- A. CONNECTS TO H
- B. CONNECTS TO I
- C. CONNECTS TO #2
- D. CONNECTS TO #6
- 1. CONNECTS TO AUXILIARY BATTERY (WHEN USED)
- 2. CONNECTS TO C
- 3. CONNECTS TO ON/OFF IGNITION THRU CHARGE LIGHT
- 4. CONNECTS TO H
- 5. CONNECTS TO B
- 6. CONNECTS TO D
- 7. CONNECTS TO H

### REGULATOR PIN FUNCTION

- 1. S2 REMOTE SENSE FOR THE AUXILIARY BATTERY
- 2. F REGULATOR OUTPUT (DRIVES FIELD WINDING)
- 3. I TURNS REGULATOR ON (ON/OFF IGNITION)
- 4. S1 REMOTE SENSE FOR THE MAIN BATTERY
- 5. GND CIRCUIT GROUNDING FOR THE REGULATOR
- 6. S 4 WIRE HOOK-UP (TURNS WARNING LIGHT OFF WHEN ALTERNATOR IS WORKING)
- 7. A POWER SUPPLY TO REGULATOR AND FIELD
- 8. 14MAX FROM HALOGEN LIGHT SWITCH (OPTIONAL)
- 9. TACH TACHOMETER OUTPUT (OPTIONAL)

## 24HD SERIES: WIRING CONNECTIONS

(12 VOLT 160, 190 & 220 AMP)

EXTERNAL REGULATOR: 10-11

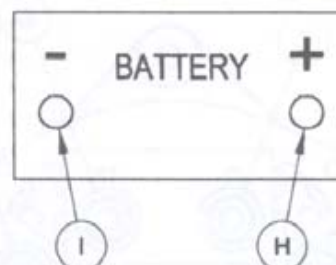
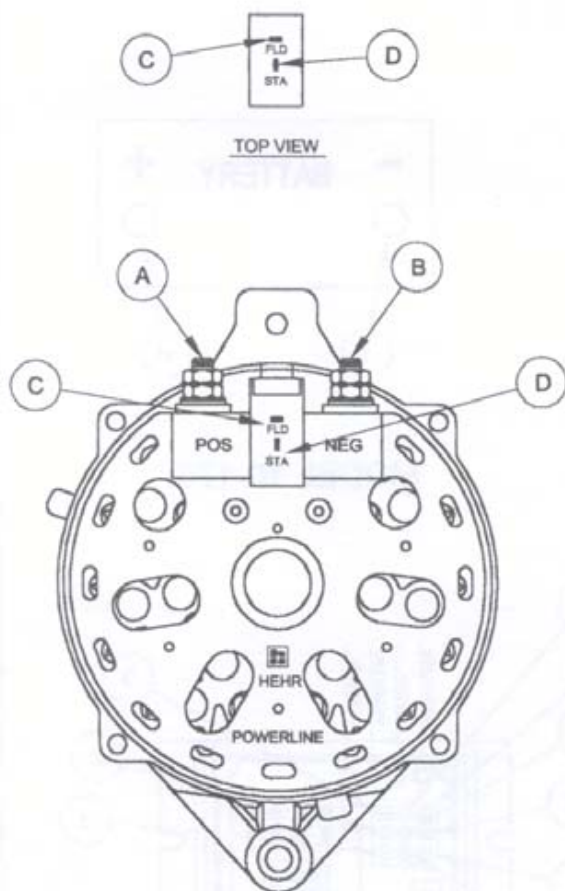

MODEL 10-11

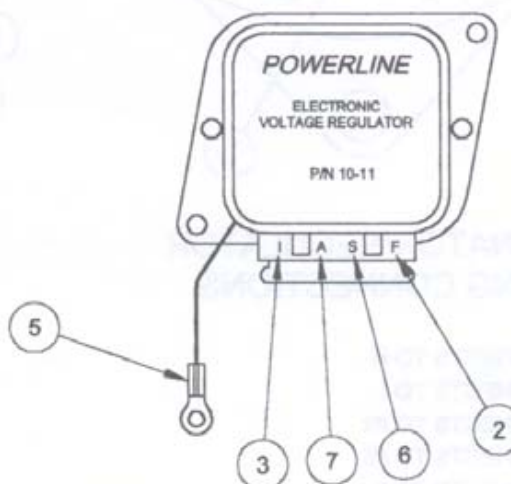

### 3 WIRE SYSTEMS

- A. CONNECTS TO H
- B. CONNECTS TO I
- C. CONNECTS TO #2
- D. NOT USED (TACHOMETER CONNECTION)
- 3. NOT USED
- 5. CONNECTS TO A GOOD GROUND CONNECTION
- 6. CONNECTS TO ON/OFF IGNITION
- 7. CONNECTS TO H

### 4 WIRE SYSTEMS

- A. CONNECTS TO H
- B. CONNECTS TO I
- C. CONNECTS TO #2
- D. CONNECTS TO #6 (ALSO TACHOMETER CONNECTION)
- 3. CONNECTS TO ON/OFF IGNITION THRU CHARGE LIGHT
- 5. CONNECTS TO A GOOD GROUND CONNECTION
- 6. CONNECTS TO D
- 7. CONNECTS TO H

### REGULATOR PIN FUNCTION

- 2. F REGULATOR OUTPUT (DRIVES FIELD WINDING OF ALTERNATOR)
- 3. I TURNS REGULATOR ON (4 WIRE HOOK-UP)
- 5. CASE CIRCUIT GROUND FOR REGULATOR
- 6. S 3 WIRE HOOK-UP (TURNS REGULATOR ON) 4 WIRE HOOK-UP (TURNS WARNING LIGHT OFF WHEN ALTERNATOR IS WORKING)
- 7. A POWER SUPPLY AND VOLTAGE SENSE LEAD FOR REGULATORS (ALL MODELS)



## 24HD SERIES: WIRING CONNECTIONS

(14 VOLT, 160, 190 & 220 AMP)

EXTERNAL REGULATOR: 10-130

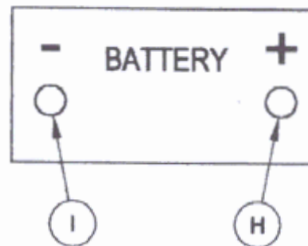
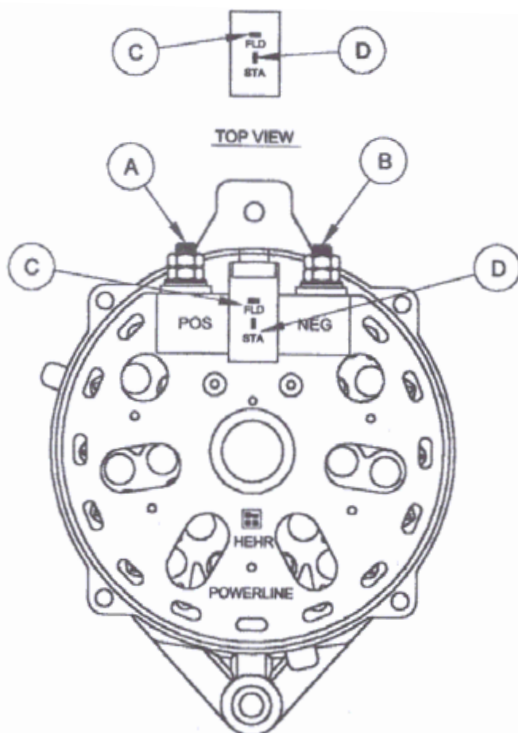

10-129 & 10-130

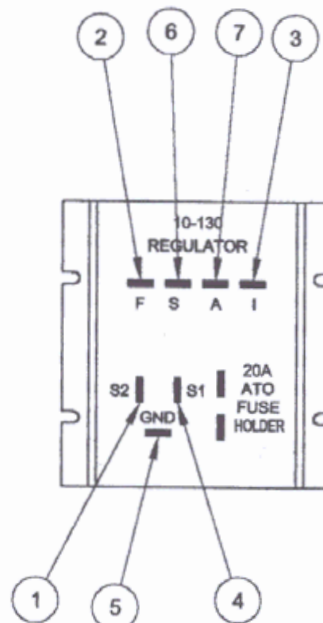

### 6 WIRE SYSTEMS

- A. CONNECTS TO H
- B. CONNECTS TO I
- C. CONNECTS TO #2
- D. NOT USED
- 1. CONNECTS TO AUXILIARY BATTERY (WHEN USED)
- 2. CONNECTS TO C
- 3. NOT USED
- 4. CONNECTS TO H
- 5. CONNECTS TO B
- 6. CONNECTS TO ON/OFF IGNITION
- 7. CONNECTS TO H

### 7 WIRE SYSTEMS

- A. CONNECTS TO H
- B. CONNECTS TO I
- C. CONNECTS TO #2
- D. CONNECTS TO #6
- 1. CONNECTS TO AUXILIARY BATTERY (WHEN USED)
- 2. CONNECTS TO C
- 3. CONNECTS TO ON/OFF IGNITION
- 4. CONNECTS TO H
- 5. CONNECTS TO B
- 6. CONNECTS TO D
- 7. CONNECTS TO H

### REGULATOR PIN FUNCTION

- 1. S2 REMOTE SENSE FOR THE AUXILIARY BATTERY
- 2. F REGULATOR OUTPUT (DRIVES FIELD WINDING)
- 3. I TURNS REGULATOR ON (7 WIRE HOOK-UP)
- 4. S1 REMOTE SENSE FOR THE MAIN BATTERY
- 5. GND CIRCUIT GROUNDING FOR THE MAIN BATTERY
- 6. S1 6 WIRE HOOK-UP (TURNS REGULATOR ON)  
7 WIRE HOOK-UP (TURNS WARNING LIGHT OFF WHEN ALTERNATOR IS WORKING)
- 7. A POWER SUPPLY TO REGULATOR AND FIELD

## 24HD SERIES: WIRING CONNECTIONS

(12 VOLT 100, 160, 190 & 220 AMP)  
EXTERNAL REGULATOR 10-170 & 10-172

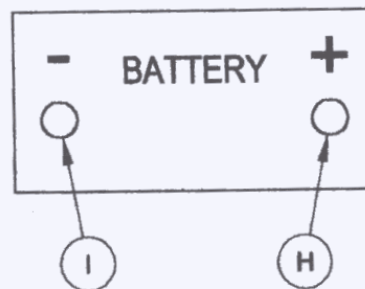
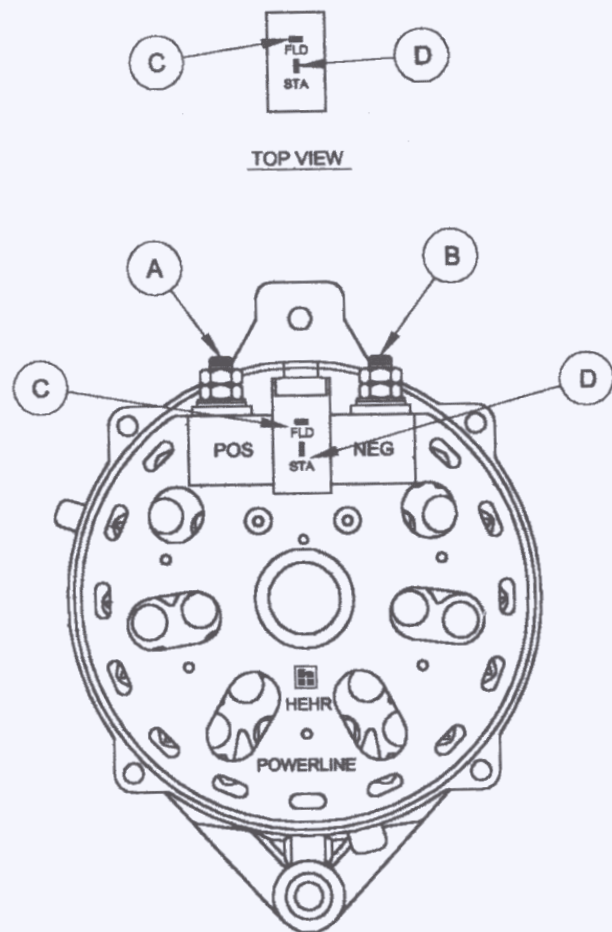

MODEL 10-170 & 10-172

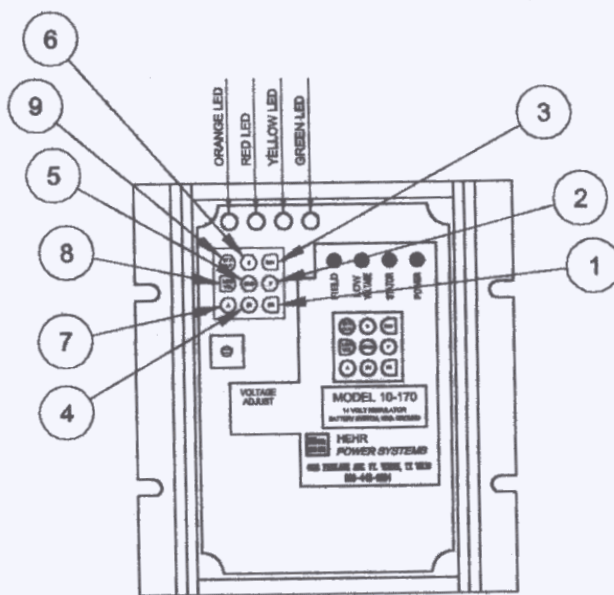

### 6/7 WIRE SYSTEM

- A. CONNECTS TO H
- B. CONNECTS TO I
- C. CONNECTS TO #2
- D. CONNECTS TO #6
- 1. CONNECTS TO AUXILIARY BATTERY (WHEN USED)
- 2. CONNECTS TO C
- 3. CONNECTS TO ON/OFF IGNITION THRU CHARGE LIGHT
- 4. CONNECTS TO H
- 5. CONNECTS TO B
- 6. CONNECTS TO D
- 7. CONNECTS TO H

### REGULATOR PIN FUNCTION

- 1. S2 REMOTE SENSE FOR THE AUXILIARY BATTERY
- 2. F REGULATOR OUTPUT (DRIVES FIELD WINDING)
- 3. I TURNS REGULATOR ON (ON/OFF IGNITION)
- 4. S1 REMOTE SENSE FOR THE MAIN BATTERY
- 5. GND CIRCUIT GROUNDING FOR THE REGULATOR
- 6. S 7 WIRE HOOK-UP (TURNS WARNING LIGHT OFF WHEN ALTERNATOR IS WORKING)
- 7. A POWER SUPPLY TO REGULATOR AND FIELD
- 8. 14MAX FROM HALOGEN LIGHT SWITCH (OPTIONAL)
- 9. TACH TACHOMETER OUTPUT (OPTIONAL)

## VOLTAGE TEST FOR 10-11 REGULATOR 23HD AND 24HD SERIES ALTERNATOR

### 3 WIRE CONNECTIONS

TERM #	TERMINALS	IGNITION OFF	IGNITION ON ENGINE NOT RUNNING	ENGINE RUNNING
3	Reg Term I	Not Used	Not Used	Not Used
7	Reg Term A	12.6 Volts	12.6 Volts Approx.	14 Volts
6	Reg Term S	0 Volts	12 Volts Approx.	13-14 Volts
2	Reg Term F	0 Volts	10-11 Volts Approx.	4-12 Volts
D	Alt. R/S Term	0 Volts	0 Volts	7 Volts
C	Alt. F Term	0 Volts	10-11 Volts Approx.	4-12 Volts
A	Alt. Pos. Term	12.6 Volts	12.6 Volts	14 Volts
Q	*Isol A Term	0 Volts	0 Volts	14.5 - 15 Volts
P	*Isol B1 Term	12.6 Volts	12.6 Volts	13.5 - 14 Volts
R	*Isol B2 Term	12.6 Volts	12.6 Volts	13.5 - 14 Volts
A	*Alt. Positive term w/Isol.	0 Volts	0 Volts	14.5 - 15 Volts

\*Test points when isolator used

### 7 WIRE CONNECTIONS

TERM #	TERMINALS	IGNITION OFF	IGNITION ON ENGINE NOT RUNNING	ENGINE RUNNING
3	Reg Term I	0 Volts	2 Volts Approx.	2-10 Volts
7	Reg Term A	12.6 Volts	12.6 Volts	14 Volts
6	Reg Term S	0 Volts	0 Volts	7 Volts Approx.
2	Reg Term F	0 Volts	10-11 Volts	4-11 Volts
D	Alt. R/S Term	0 Volts	0 Volts	7 Volts Approx.
C	Alt. F Term	0 Volts	10-11 Volts	4-11 Volts
A	Alt. Pos. Term	12.6 Volts	12.6 Volts	14 Volts
Q	*Isol A Term	0 Volts	0 Volts	14.5 - 15 Volts
P	*Isol B1 Term	12.6 Volts	12.6 Volts	13.5 - 14 Volts
R	*Isol B2 Term	12.6 Volts	12.6 Volts	13.5 - 14 Volts
A	*Alt. Positive term w/Isol.	0 Volts	0 Volts	14.5 - 15 Volts

\*Test points when isolator used

## VOLTAGE TEST FOR 10-130 REGULATOR 23HD AND 24HD SERIES ALTERNATOR

6 WIRE CONNECTIONS				
TERM #	TERMINALS	IGNITION OFF	IGNITION ON ENGINE NOT RUNNING	ENGINE RUNNING
3	Reg Term I	Not Used	Not Used	Not Used
7	Reg Term A	12.6 Volts	12.6 Volts	14 Volts
6	Reg Term S	0 Volts	12 Volts Approx.	13-14 Volts
2	Reg Term F	0 Volts	10-11 Volts	4-11 Volts
4	Reg Term, S1	12.6 Volts	12.6 Volts	14 Volts
1	*Reg Term S2	12.6 Volts	12.6 Volts	14 Volts
D	Alt. R/S Term	0 Volts	0 Volts	7 Volts
C	Alt. F Term	0 Volts	10-11 Volts	4-11 Volts
A	Alt. Pos. Term	12.6 Volts	12.6 Volts	14 Volts
Q	*Isol A Term	0 Volts	0 Volts	14.5 - 15 Volts
P	*Isol B1 Term	12.6 Volts	12.6 Volts	13.5 - 14 Volts
R	*Isol B2 Term	12.6 Volts	12.6 Volts	13.5 - 14 Volts
A	*Alt. Positive term w/Isol.	0 Volts	0 Volts	14.5 - 15 Volts

**\*Test points when isolator used. S2 only used with isolator in system**

7 WIRE CONNECTIONS				
TERM #	TERMINALS	IGNITION OFF	IGNITION ON ENGINE NOT RUNNING	ENGINE RUNNING
3	Reg Term I	0 Volts	2 Volts Approx.	2-10 Volts
7	Reg Term A	12.6 Volts	12.6 Volts	14 Volts
6	Reg Term S	0 Volts	0 Volts	7 Volts Approx.
2	Reg Term F	0 Volts	10-11 Volts	4-11 Volts
4	Reg Term S1	12.6 Volts	12.6 Volts	14 Volts
1	*Reg Term S2	12.6 Volts	12.6 Volts	14 Volts
D	Alt. R/S Term	0 Volts	0 Volts	7 Volts Approx.
C	Alt. F Term	0 Volts	10-11 Volts	4-11 Volts
A	Alt. Pos. Term	12.6 Volts	12.6 Volts	14 Volts
Q	*Isol A Term	0 Volts	0 Volts	14.5 - 15 Volts
P	*Isol B1 Term	12.6 Volts	12.6 Volts	13.5 - 14 Volts
R	*Isol B2 Term	12.6 Volts	12.6 Volts	13.5 - 14 Volts
A	*Alt. Positive term w/Isol.	0 Volts	0 Volts	14.5 - 15 Volts

**\*Test points when isolator used. S2 only used with isolator in system**

## VOLTAGE TEST FOR 10-170/10-172 REGULATOR 23HD AND 24HD SERIES ALTERNATOR

7 WIRE CONNECTIONS				
TERM #	TERMINALS	IGNITION OFF	IGNITION ON ENGINE NOT RUNNING	ENGINE RUNNING
3	Reg Term I	0 Volts	1.5 - 3 Volts	14 Volts
7	Reg Term A	12.6 Volts	12.6 Volts	14 Volts
6	Reg Term S	0 Volts	0 Volts	7 Volts Approx.
2	Reg Term F	0 Volts	.8 - 2.4 Volts	4-11 Volts
4	Reg Term S1	12.6 Volts	12.6 Volts	14 Volts
1	*Reg Term S2	12.6 Volts	12.6 Volts	14 Volts
D	Alt. R/S Term	0 Volts	0 Volts	7 Volts Approx.
C	Alt. F Term	0 Volts	.8 - 2.4 Volts	4-11 Volts
A	Alt. Pos. Term	12.6 Volts	12.6 Volts	14 Volts
Q	*Isol A Term	0 Volts	0 Volts	14.5 - 15 Volts
P	*Isol B1 Term	12.6 Volts	12.6 Volts	14 Volts
R	*Isol B2 Term	12.6 Volts	12.6 Volts	14 Volts
A	*Alt. Positive term w/Isol.	0 Volts	0 Volts	14.5 - 15 Volts

**\*Test points when isolator used. S2 only used with isolator in system**

### DIAGNOSTIC LED FUNCTIONS

1. **Green** LED is on when "A" Terminal has voltage and internal 5 Volts supply is working
2. **Orange** LED is on when the field terminal is high. It is also on when the ignition is on and the engine is not running.
3. **Yellow** LED is on when engine is running and the alternator is working (7 Volt stator output is present)
4. **Red** LED indicates a low voltage condition the "A" Terminal voltage has dropped below 12.6 Volts

**Note: It is normal for Red and Orange LED to flash at low alternator RPM**

# HOW TO FULL FIELD ALTERNATORS

## Full Field 23HD and 24HD Series at Alternator

1. Remove field/stator plug from alternator and tape up.
2. Connect a voltmeter between Terminal "A" (Positive output post) and Terminal "B" (Negative post of alternator ground).
3. Attach A jumper from Terminal "C" (Field Terminal to Positive output post (Terminal "A"). If system had an isolator connect jumper between Terminal "C" and a 12-volt source.
4. Start engine and run at 800 to 1000 RPM's. Alternator voltage should increase to 15-16 volts. If the voltage fails to increase the alternator is bad.
5. If the alternator voltage increases the regulator or wiring harness could be the problem.

## Full Field 23HD and 24HD Series at Regulator

1. Remove the 4 Terminal (or 9 Pin Terminal) plastic plug from regulator.
2. With key on, check brown or green/red lead in harness (Terminal 3), voltage should be from 2 to 10 volts. Check voltage on red or yellow lead in harness (Terminal "7"), this lead must have 12 volts at all times.
3. With engine running at 800-1000 RPM's jump between Terminal position "7" and Terminal position "2" (This is A (#7) and F (#2) position) in plastic plug. The voltage should increase to 15-16 volts on a good alternator and wiring harness. If it works with above test and this test. The problem may be the regulator.
4. If the alternator fails to work but works with it at full field; either the harness is bad or voltage was not present on terminal A ("7").

## Fuse in System

1. 10-130 has 20 Amp fuse on regulator. Check fuse if no field current is present.
2. 10-130, 10-170 and 10-172 harnesses have a 20 Amp fuse in Red lead. Check if no field current is present. S1 red/white lead has 5 Amp fuse. Fuse must be good for correct regulator operation. S2 red/yellow lead has a 5 Amp fuse. Fuse must be good for correct auxiliary battery operation.

# TEST FOR AMP LOAD ON VEHICLE

## Equipment Required to Test Alternator

1. Battery
2. Battery Tester
3. Clamp on Amp meter
5. Photo Electric Tachometer
6. Battery Post Cleaner
7. Jumper Lead with Clips

## TEST PROCEDURE

- 1) Test battery to be sure it is full charged and clean cable connections
- 2) Connect voltmeter across positive and negative battery terminals
- 3) Clamp a clamp-on Amp meter over positive battery cable at battery.
- 4) Turn on every load possible with engine not running. Record Amp draw and voltage. If more than one cable, measure each cable's Amp draw and record. Then add all current draws together to get total Amp draw on vehicle.
- 5) Connect voltmeter on positive and negative post of alternator.
- 6) Clamp a clamp-on Amp meter around positive cable at alternator. Start engine. Record voltage and Amps at idle speed.
- 7) Turn on all loads and record voltage and Amps at rear of alternator.
- 8) If load measured at batteries with engine off exceeds Amperage coming out of alternator, increase engine speed until Amperage meets or exceeds the total load that was measured at batteries.
- 9) If engine speed is too high or you are unable to meet the load, the problem may be with pulley ratio or the alternator Amp rating is too small for the load.
- 10) To correct the problem will require a pulley change on the alternator to improve ratio or change both the alternator and pulley to provide more Amps and a better pulley ration.

## **BENCH TEST PROCEDURES (23HD/24HD SERIES ALTERNATOR)**

### A. Items required for test:

1. A variable speed test bench with enough house power to turn alternator at least 8500 RPM. We recommend at least a 20 horsepower drive motor.
2. Heavy duty clamp on Amp meter.
3. Heavy-duty voltmeter.
4. Photoelectric tachometer.

### B. Test procedures:

1. Install alternator on test stand.
2. Connect a regulator up to alternator.
3. Connect a voltmeter to positive and negative terminals at alternator.
4. Clamp an Amp meter around positive cable at alternator.
5. Start test stand and stabilize at 2000 alternator RPM's.

### C. Test run:

1. Locate correct power curve at rear of this manual for alternator being tested.
2. Run alternator at various speeds and apply loads at various levels against power curves.  
**MAINTAIN VOLTAGE AT APPROXIMATELY 14.0 VOLTS**
3. If unable to get output within 5% of output curve while maintaining the desired voltage, check the **FIELD VOLTAGE**.
4. To check the field voltage, insert a probe into plug on alternator field position. Attach a voltmeter to the probe. Compare the voltage registered here with the voltage, which is read across the positive and negative terminals. At a full load condition the field voltage should read within .5 volts of what is read across positive and negative terminals of the alternator.
5. If field voltage is low it is possible that you have a regulator that will not allow enough field voltage to the rotor and thus a drop in alternator output.
6. If you find step 5 to be the problem, you must full field the alternator. See how to full field on page 33. Results should be an increase in both voltage and Amperage output.
7. If no increase is realized, there is quite possibly a problem inside the alternator. It should be opened up for inspection to determine the nature of the problem.
8. If an increase is realized that indicates a problem with the regulator and it should be replaced.



## **ISOLATOR TEST**

**(Refer to drawing on page 10)**

**Tools Needed:**

12 Volt test light  
12 Volt vehicle battery  
Volt/OHM meter

### **TEST USING BATTERY AND TEST LIGHT**

- Step 1. Disconnect all cables from isolator.
- Step 2. Attach lead of test light to battery negative (1).
- Step 3. Attach jumper cable from battery positive (H) to alternator terminal (Q) of isolator.
- Step 4. Touch test light to B1 terminal (P) and to B2 terminal (R) test light should light.
- Step 5. Attach lead of test light to battery positive (H).
- Step 6. Attach jumper cable from battery negative (I) to alternator terminal (Q) of isolator.
- Step 7. Touch test light B1 terminal (P) and to B2 terminal (R) test light should not light.
- Step 8. Attach jumper from battery negative (I) to case ground to isolator (make sure of good connection). Attach test light lead to battery positive (H). Touch test light to terminals "P", "Q", and "R" of isolator. Test light should not light.

### **TEST USING VOLT/OHM METER**

- Step 1. Disconnect all cables from isolator.
- Step 2. Set Volt/OHM meter on diode scale.
- Step 3. Attach positive lead of meter to terminal A (Q) of isolator.
- Step 4. Touch terminals B1 (P) and B2 (R) with negative lead of meter. You should get a reading.
- Step 5. Attach negative lead of meter to terminal A (Q) of isolator.
- Step 6. Touch terminals B1 (P) and B2 (R) with positive lead of meter. You should not get a reading.
- Step 7. Attach positive lead of meter to case of isolator. Touch terminals "P", "Q", and "R". You should not get a reading.

**Note: On some import OHM meters the red and black leads are reversed for above test.**

### **TEST USING VOLT/OHM METER**

- Step 1. Disconnect all cables from isolator.
- Step 2. Set volt/OHM meter on diode scale.
- Step 3. Attach terminals B1 (P) and B3 (R) with negative lead of meter. You should get a reading.
- Step 4. Touch terminals B1 (P) and B3 (R) with negative lead of meter. You should get a reading.

## FINDING THE PULLEY RATIO

**The correct pulley ratio is very important for correct alternator performance.**

1. A pulley ratio of 3 to 1 is preferred, or a ratio as close to 3 to 1 as possible. It is recommended not to use a ratio less than 2.5 to 1.
2. To find the pulley ratio: Measure the diameter of the crankshaft pulley (or the pulley driving the alternator) and the diameter of the alternator pulley.

**Note:** Measure V belt pulleys on total outside diameter.

Measure serpentine belt pulleys across the top of the grooves the belt rides on.

3. Divide the diameter of the crankshaft pulley by the diameter of the alternator pulley. This will give you the pulley ratio.
4. On engines with an alternator driven off an accessory drive it is necessary to use a photo tachometer to figure ratios. \*
5. To find the ratio using a photo tachometer: Measure the speed of the crankshaft pulley. Measure the speed of the alternator pulley. Divide the alternator pulley speed by the crankshaft pulley speed; this will give you the ratio.
6. To find alternators current capability at any given RPM refer to the alternator power curves in this book. Page 41 thru 44.

**Note:** The power curves show alternator RPM, you must multiply engine RPM by ratio to get alternator speed.

\* Sometimes the alternator is driven by a pulley other than the crankshaft, and that drive pulley sometimes is designed to run at 2 to 2 ½ times the engine crankshaft speed: in these instances call 1-800-433-9394 for assistance.

## RECOMMENDED BATTERY CABLE SIZE (AS A FUNCTION OF CURRENT AND LENGTH)

SYSTEM VOLTAGE	RATED OUTPUT (AMPS)	MINIMUM SIZE CABLE TO USE (AWG)					
		UP TO 5 FT.	5-10 FT.	10-15 FT.	15-20 FT.	20-25 FT.	25-30 FT.
12 VOLT	0-60	8 AWG	4 AWG	2 AWG	2 AWG	1 AWG	0 AWG
	60-100	6 AWG	4 AWG	1 AWG	0 AWG	0 AWG	2/0 AWG
	100-150	4 AWG	2 AWG	0 AWG	2/0 AWG	2/0 AWG	3/0 AWG
	150-190	4 AWG	1 AWG	2/0 AWG	3/0 AWG	4/0 AWG	4/0 AWG
	190-250	2 AWG	0 AWG	2/0 AWG	4/0 AWG	4/0 AWG	4/0 AWG
	250-300	0 AWG	2/0 AWG	3/0 AWG	4/0 AWG	4/0 AWG	4/0 AWG
24 VOLT	0-30	14 AWG	14 AWG	10 AWG	8 AWG	8 AWG	6 AWG
	30-50	12 AWG	10 AWG	8 AWG	6 AWG	6 AWG	4 AWG
	50-75	10 AWG	8 AWG	6 AWG	4 AWG	4 AWG	2 AWG
	75-100	6 AWG	6 AWG	4 AWG	4 AWG	2 AWG	1 AWG
	100-125	4 AWG	4 AWG	4 AWG	2 AWG	2 AWG	1 AWG
	125-150	2 AWG	2 AWG	1 AWG	1 AWG	0 AWG	0 AWG

CONVERSION OF WIRE SIZES			
AWG METRIC (MM <sup>2</sup> )		AWG METRIC (MM <sup>2</sup> )	
14	2	2	32
12	3	1	40
10	5	0	50
8	8	2/0	62
6	13	3/0	81
4	19	4/0	103

- NOTE
1. Cable length must include both positive and negative cables.
  2. Maximum acceptable voltage drop = 0.5 volts in a 12 volt system or 1.0 volts in a 24 system with ambient temperature surrounding cables is 150°F or less.

### 23HD SERIES, 120 AMP, 12V

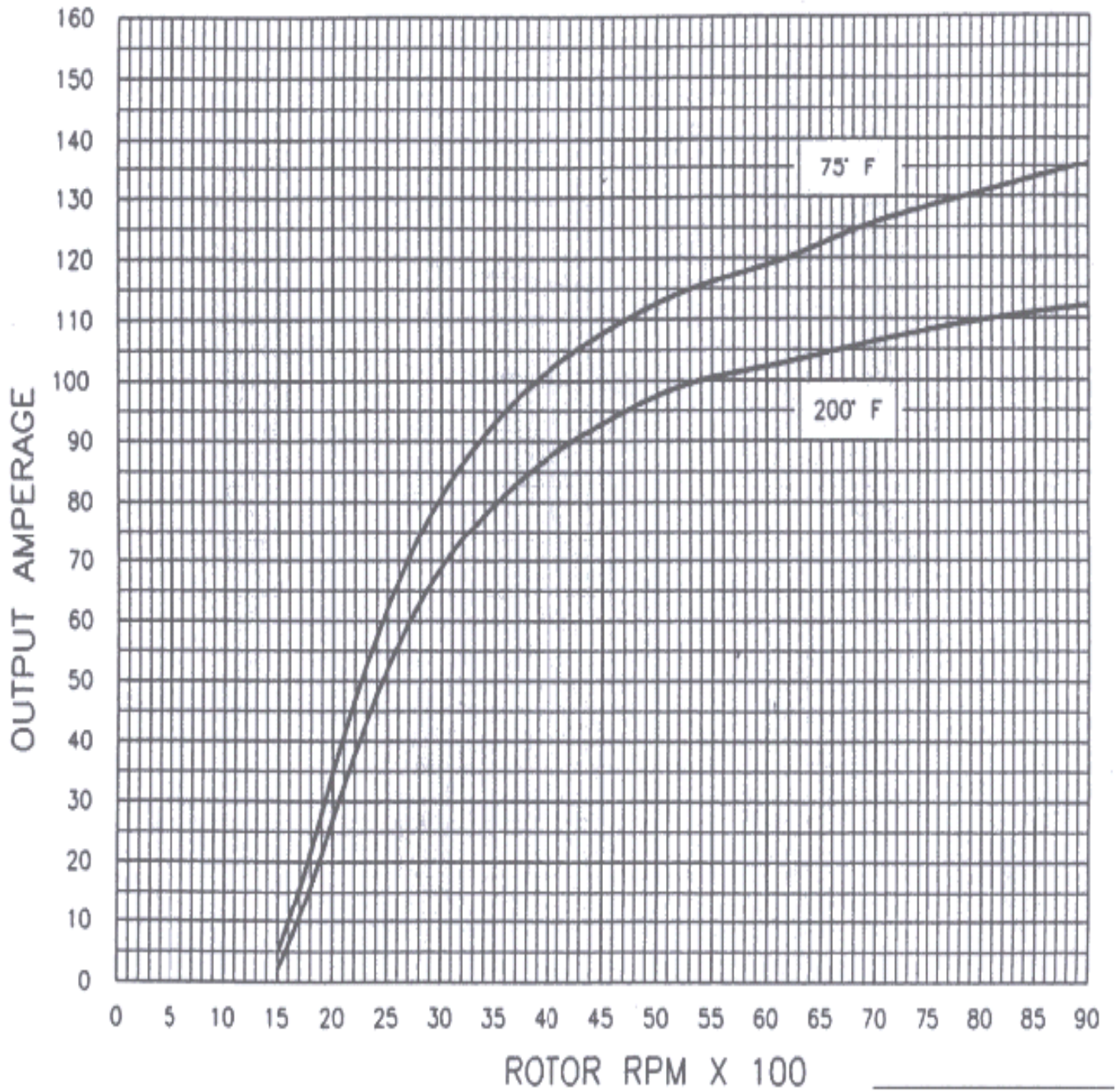

### 24HD SERIES, 160 AMP, 12V

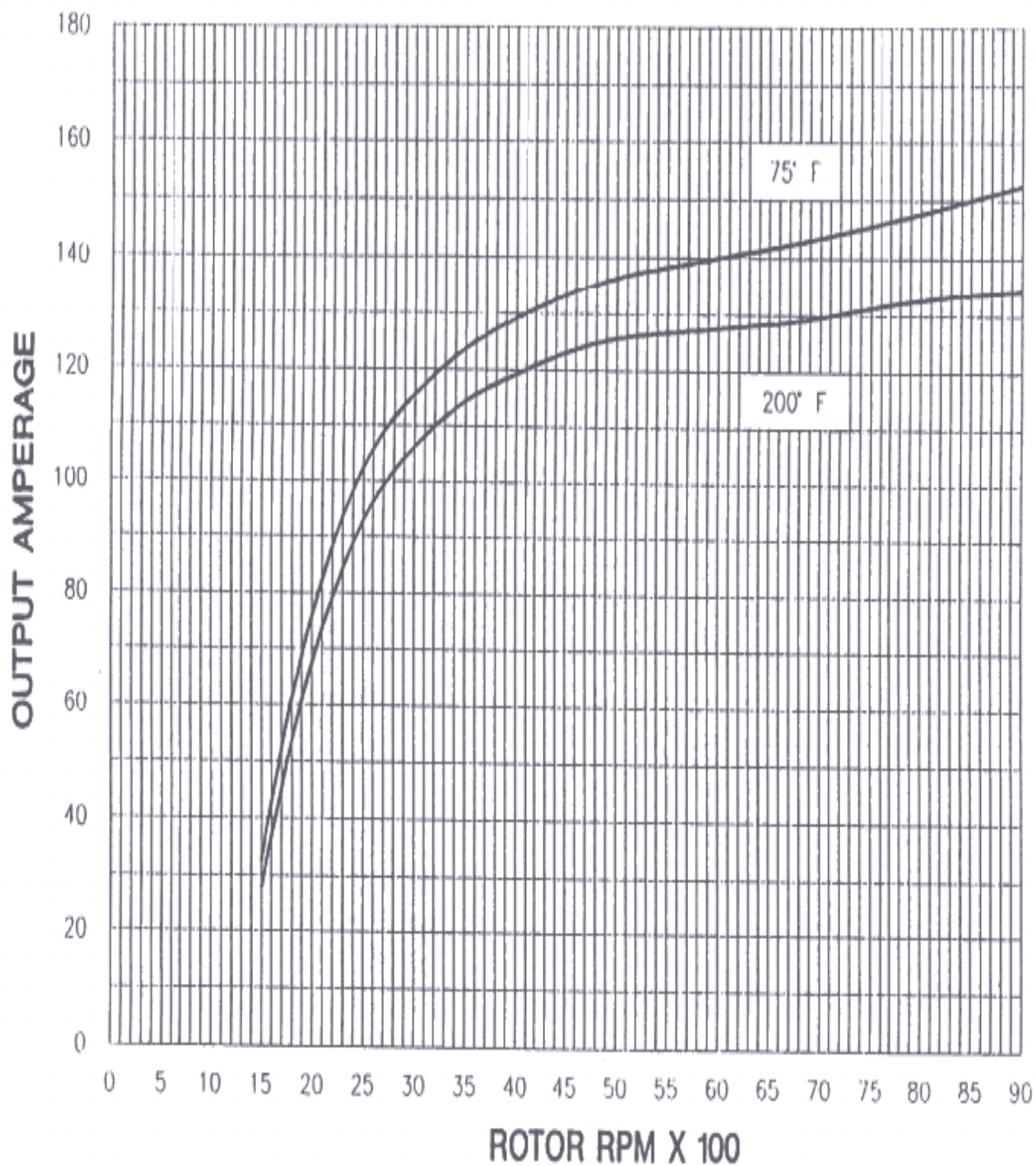

### 24HD SERIES, 190 AMP, 12V

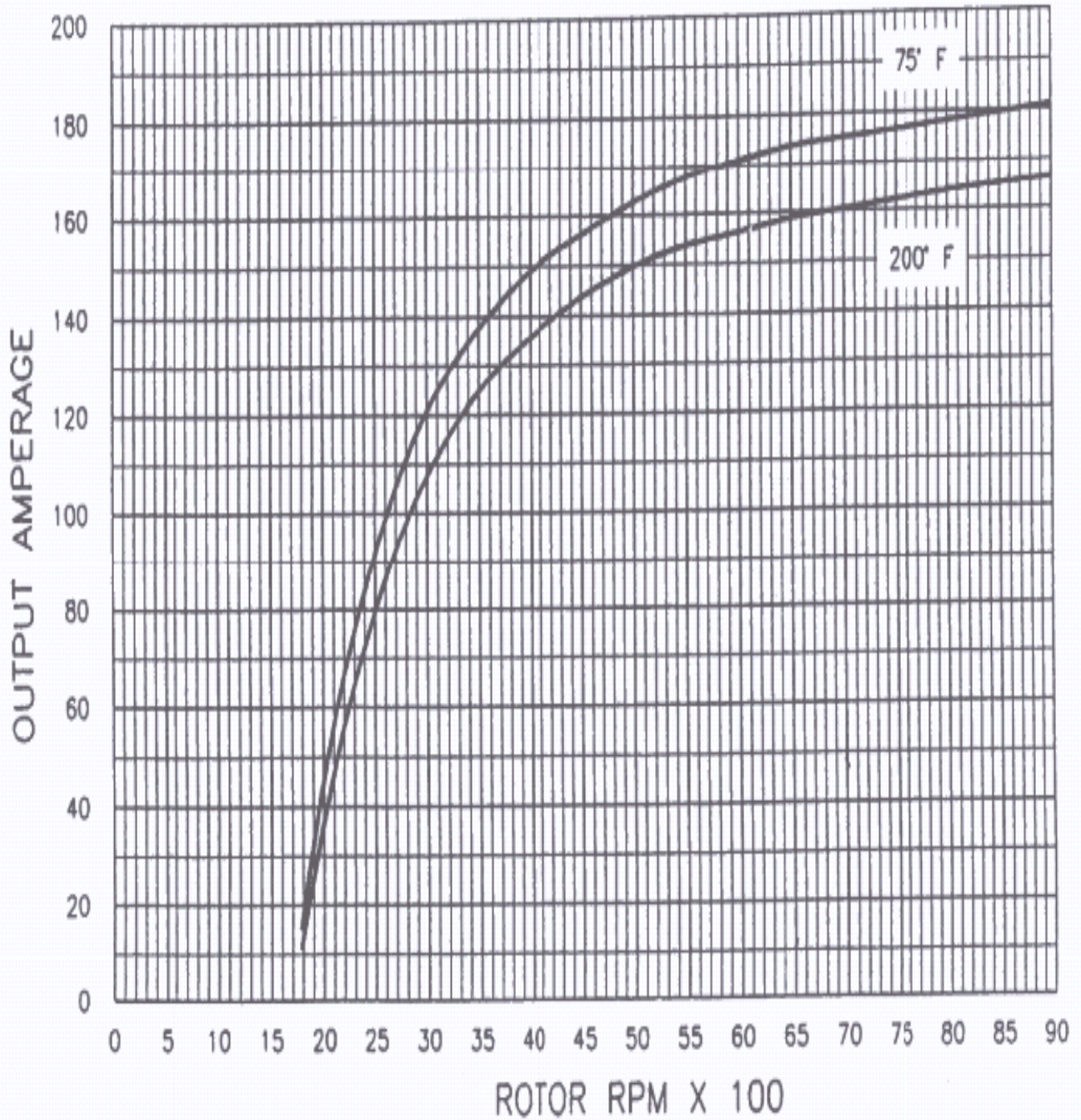

### 24HD SERIES, 220 AMP, 12V

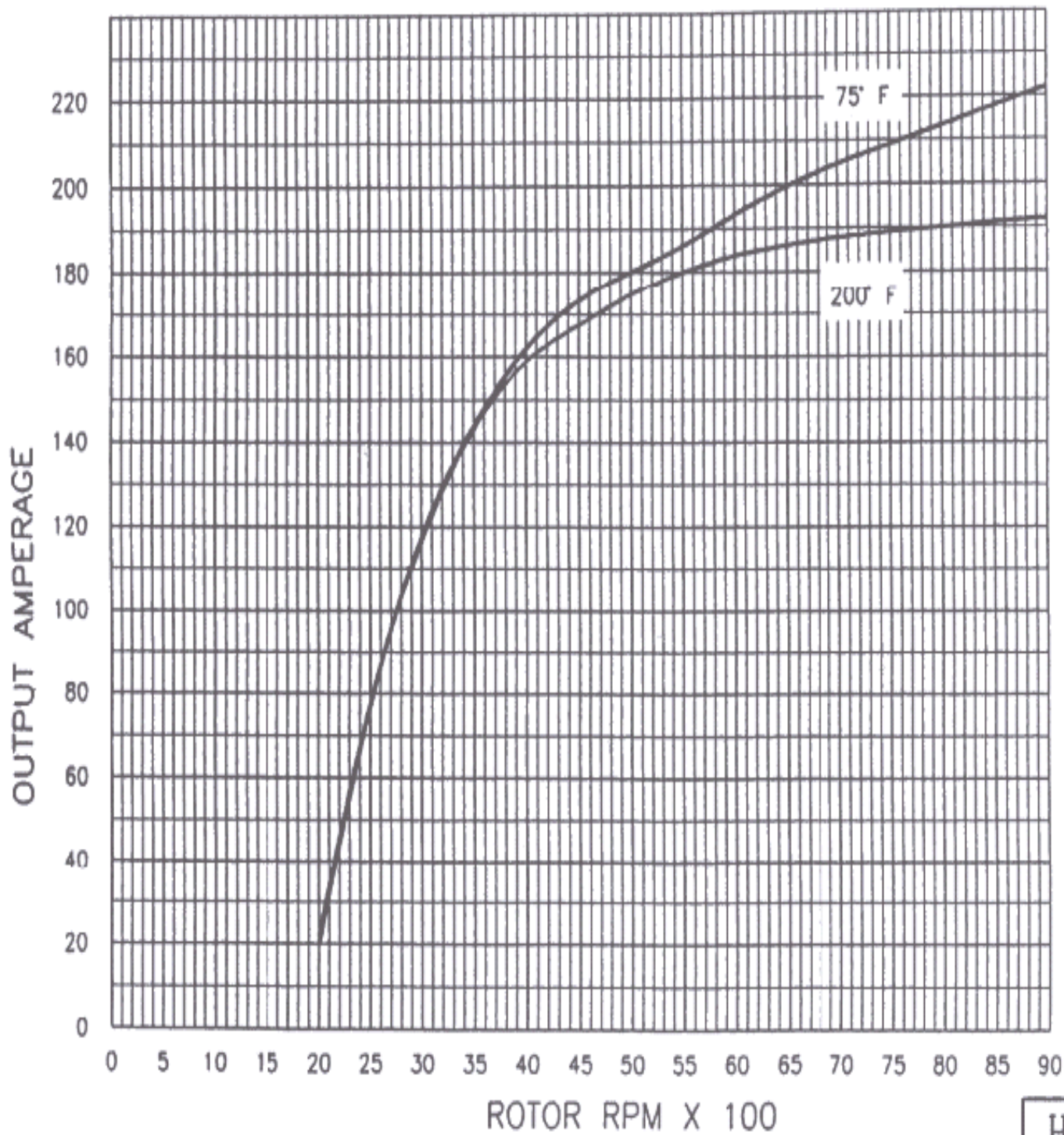

## MISCELLANEOUS ALTERNATOR INFORMATION

**FIELD VOLTAGE**

<b>LOAD</b>	<b>12 VOLTS</b>	<b>24 VOLTS</b>
LIGHT LOAD	1-4 VOLTS	2-8 VOLTS
MEDIUM LOAD	5-9 VOLTS	10-18 VOLTS
HEAVY LOAD	10-13.5 VOLTS	20-28 VOLTS

**FIELD CURRENT MAXIMUM DRAW**

<b>SERIES</b>	<b>AMPS</b>	<b>VOLTS</b>
23HD	4.5-5	12.6
24HD	5.5-6	12.6

**ROTOR OHMS** (Measure across slip rings)

<b>SERIES</b>	<b>OHMS</b>
23HD	2.5-2.8
24HD	1.9-2.2

**NUMBER OF POLES ON ROTOR**

<b>SERIES</b>	<b>POLES</b>
23HD	14
24HD	12



## VOLTAGE TEST FOR 10-9

3 WIRE CONNECTION				
TERM #	TERMINALS	IGNITION OFF	IGNITION ON ENGINE NOT RUNNING	ENGINE RUNNING
3	Reg Term I	-----	Not Used	-----
7	Reg Term A	24.5 - 25 Volts	24.5 - 25 Volts	27 - 29 Volts
6	Reg Term S	0 Volts	24.5 - 25 Volts	26 - 28 Volts
2	Reg Term F	0 Volts	22 - 23.5 Volts	10 - 23.5 Volts
D	Alt Term R/S	0 Volts	0 Volts	13.5 to 14.5 Volts
C	Alt Term F	0 Volts	22 - 23.5 Volts	10 - 23.5 Volts
A	Alt Pos. Term	24.5 - 25 Volts	24.5 - 25 Volts	27 - 29 Volts
Q	*Isol A Term	0 Volts	0 Volts	28 - 30 Volts
P	*Isol B1 Term	24.5 - 25 Volts	24.5 - 25 Volts	27 - 29 Volts
R	*Isol B2 Term	24.5 - 25 Volts	24.5 - 25 Volts	27 - 29 Volts
A	*Alt Pos. w/ Isol	0 Volts	0 Volts	28 - 30 Volts

## VOLTAGE TEST FOR 10-129

6 WIRE CONNECTION NO LAMP USED				
TERM #	TERMINALS	IGNITION OFF	IGNITION ON ENGINE NOT RUNNING	ENGINE RUNNING
3	Reg Term I	-----	Not Used	-----
7	Reg Term A	24.5 - 25 Volts	24.5 - 25 Volts	27 - 29 Volts
6	Reg Term S	0 Volts	24.5 - 25 Volts	26 - 28 Volts
2	Reg Term F	0 Volts	22 - 23.5 Volts	10 - 23.5 Volts
4	Reg Term S1	24.5 - 25 Volts	24.5 - 25 Volts	27 - 29 Volts
1	*Reg Term S2	24.5 - 25 Volts	24.5 - 25 Volts	27 - 29 Volts
D	Alt Term R/S	0 Volts	0 Volts	13.5 to 14.5 Volts
C	Alt Term F	0 Volts	22 - 23.5 Volts	10 - 23.5 Volts
A	Alt Pos. Term	24.5 - 25 Volts	24.5 - 25 Volts	27 - 29 Volts
Q	*Isol A Term	0 Volts	0 Volts	28 - 30 Volts
P	*Isol B1 Term	24.5 - 25 Volts	24.5 - 25 Volts	27 - 29 Volts
R	*Isol B2 Term	24.5 - 25 Volts	24.5 - 25 Volts	27 - 29 Volts
A	*Alt Pos. w/ Isol	0 Volts	0 Volts	28 - 30 Volts

## VOLTAGE TEST FOR 10-175

7 WIRE CONNECTION				
TERM #	TERMINALS	IGNITION OFF	IGNITION ON ENGINE NOT RUNNING	ENGINE RUNNING
3	Reg Term I (Note 4)	0 Volts	20 - 25 Volts	24 - 27 Volts
7	Reg Term A	24.5 - 25 Volts	24.5 - 25 Volts	27 - 29 Volts
6	Reg Term S (Note 5)	0 Volts	0 Volts	13.5 to 14.5 Volts
2	Reg Term F	0 Volts	24 - 23.5 Volts	24 - 23.5 Volts
4	Reg Term S1	24.5 - 25 Volts	24.5 - 25 Volts	27 - 29 Volts
1	*Reg Term S2	24.5 - 25 Volts	24.5 - 25 Volts	27 - 29 Volts
D	Alt Term R/S	0 Volts	0 Volts	13.5 to 14.5 Volts
C	Alt Term F	0 Volts	24 - 23.5 Volts	24 - 23.5 Volts
A	Alt Pos. Term	24.5 - 25 Volts	24.5 - 25 Volts	27 - 29 Volts
Q	*Isol A Term	0 Volts	0 Volts	28 - 30 Volts
P	*Isol B1 Term	24.5 - 25 Volts	24.5 - 25 Volts	27 - 29 Volts
R	*Isol B2 Term	24.5 - 25 Volts	24.5 - 25 Volts	27 - 29 Volts
A	*Alt Pos. w/ Isol	0 Volts	0 Volts	28 - 30 Volts

- Note 1.** \*Test points when isolator is used.
- Note 2.** Terminal 1, "S2" only used with isolator in system.
- Note 3.** All voltages are approximate.
- Note 4.** Can use 28 volt lamp in this circuit if needed.

Reg I Term	Ign Off 0 Volts	24.5 - 25 Volts	24.5 - 25 Volts	27 - 29 Volts
------------	-----------------	-----------------	-----------------	---------------

- Note 5.** Stator must be connected for proper operation to stator terminal of alternator only.

**DO NOT CONNECT D.C. TO THIS TERMINAL**

**THANK YOU FOR CHOOSING**

