

# HOW TO SERVICE YOUR LEWMAR WINCH

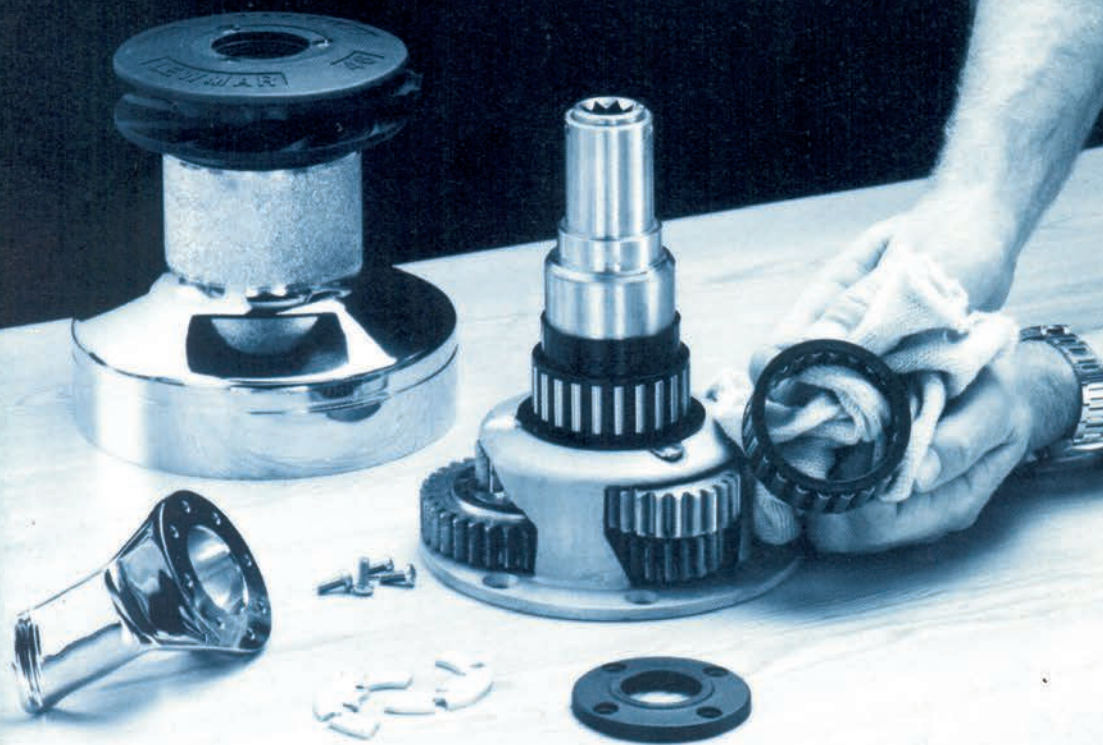

# Dear Owner

Lewmar winches are known world wide for their quality, technical innovation and performance. They have been tested to their limits by our engineers in the laboratory and by racing crews in their search for victory. They have given years of outstanding service to many thousands of yachtsmen to whom the ultimate performance of a yacht or its equipment is perhaps not so important as the pure joy of sailing a fine craft equipped with the best yacht hardware.

This booklet tells you how to give your Lewmar winches the care and attention they need to ensure that whether you sail for results, records or just pleasure, your winches will contribute that extra level of performance that is designed into each Lewmar winch.

Service details of the current range of Lewmar winches are illustrated in this booklet.

The overall servicing principles may be used for earlier versions although the detailed construction of the winches may be different.

Your Lewmar winches have been selected to perform in the best possible manner, with care and attention they will give many years use.

Incidentally, you may like to know that we're the only winch-maker to offer a total sailing system... system Lewmar. System Lewmar includes winches, blocks, shackles, travellers and hatches, portlight, all designed as a family, all working together in harmony. Included in System Lewmar is our range of patented 'WAVEGRIP'® Self Tailing Winches.

If you've ever found yourself short of hands, space, or just plain old muscle power a couple of Lewmar self tailing winches will make all the difference. By freeing you of the necessity to tail the sheet a self tailer enables you to use both hands to wind.

Lewmar's patented Wavegrip concept is simple, safe, and convenient... aren't those the features you're looking for.

All precision-engineered by Lewmar to take you closer to the ultimate sailing experience. For further details, see page 26.

Lewmar wish you good sailing for many years to come.

Lewmar Marine Ltd.

## Our guarantee of quality

Lewmar winches have been developed over many years by extensive testing aboard the world's finest racers, long distance cruising yachts and match racing yachts such as 12 metres. They are manufactured to quality standards in excess of those required by Lloyds and only the finest materials are used.



If installed, used and maintained as described in this booklet, they will give outstanding performance.

Lewmar undertake that any winch which proves defective in materials or workmanship within 1 year of the date of supply will be repaired

or replaced FREE OF CHARGE provided that the winch is returned by the registered owner to the nearest Lewmar office or distributor for examination. Lewmar reserve all rights on determining the nature of the alleged fault and their decision is final.

Contents	Page
When Do Lewmar Winches Need Servicing?	4
What Do I Need - Tools, Spares Kits, Service Manuals	4 & 5
Fitting Your Lewmar Winch	6
Using Self Tailing Winches	7
Self Tailer Adjustment - 16ST to 65ST	8
Servicing Single Speed Winches - 6, 7, 8	9
Servicing Two Speed Winches - 16, 24, 30, 40, 43, 46, 52	10-12
Servicing Three Speed Winches - 48, 55, 65	13-15
Servicing Halliard Winch - No. 1	16
Servicing One Speed Self Tailing Winches - 16ST	17
Servicing Two Speed Self Tailing Winches - 30ST, 40ST, 43ST, 46ST, 48ST, 52ST, 55ST, 65ST	18-22
Servicing Three Speed/Three Gear 55/3, 65/3, Standard and Self Tailing Winches	23
Servicing Electric Winches	24
Your Lewmar Guarantee and Counterfoil	25
Enquiry Card (including guarantee return) for Information on Other Lewmar Products	26
Lewmar Distributor and Service Addresses	26-27

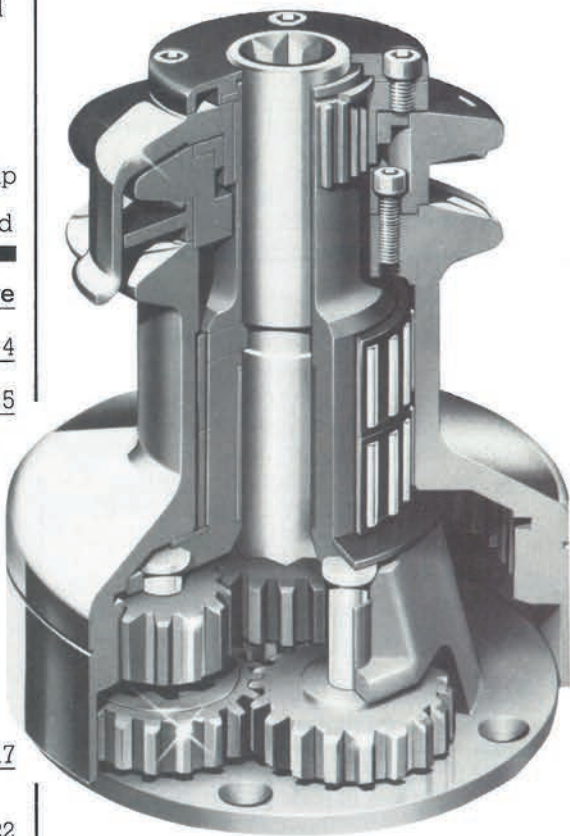

*System*  
**LEWMAR**  
*Integrated Sailing Systems*

# WHEN TO SERVICE.

## Frequency of Servicing

Lewmar winches, like any other precision engineered product, must be serviced regularly. Yacht winches are required to carry deceptively high loads. For example the genoa sheet load on a 40 foot cruising yacht could easily be 1000lbs. Regular servicing with attention to correct assembly and condition of parts is vital.

## When?

1. **MONTHLY:** All Lewmar sheet winches should be lightly oiled and greased as shown.

2. **TWO OR THREE TIMES DURING ACTIVE SAILING SEASON:** All Lewmar winches should be stripped, cleaned and re-lubricated.

3. **AT THE END OF EACH SAILING SEASON AND BEFORE STARTING THE NEW SAILING SEASON:** All Lewmar winches should be completely stripped, cleaned, thoroughly checked for damage and lubricated using the full maintenance manual.

## General External Cleaning of Drum

Chromed Winches – Wash drum regularly with fresh water and dry with chamois leather.

**OCCASIONALLY** use non abrasive liquid chrome cleaner to remove dirt deposits.

Anodised Aluminium Winches – Wash drum regularly with fresh water and dry with chamois leather. **DO NOT USE POLISHES OR ABRASIVES.**

Stainless Steel Winches – Wash drum regularly with fresh water and dry with chamois leather. **OCCASIONALLY** use non abrasive liquid cleaner to remove dirt deposits.

# WHAT YOU NEED.

## WINCH SPARES KIT

Lewmar provide a maintenance kit for each winch in their range. These kits contain parts which owners may damage or mislay. Each kit is complete and parts are not sold separately.

### Typical parts include:–

Pawls, springs, circlips, washers, locking caps, etc.

## Spares Kits

### Ref.

7001	Single speed winches.
7002	Two speed and small self tailing winches up to and including 43ST.
7003	Three speed push button winches.
7004	Self tailing winches 46ST and above.
7008	Various circlips (Owners are strongly recommended to carry spare circlips for all winches).
7009	Allen key set.
7010	Grease 100g tube.
7011	Grease 300g tub.

Don't forget to get your spares kit from your local dealer before starting a major end of season service.



## WHAT TOOLS DO I NEED?

Any winch can be stripped for servicing in seconds, using a very basic set of tools as described in the table below, and winches introduced from December 1983 onwards need nothing more than a cross head screwdriver and cleaning materials.

### Tools required, for routine servicing

Model	Tools
All models – basic requirement	Small screwdriver or knife blade Clean non-fluffy cloth Cleaning fluid Lubricants
6, 7, 8, 10, 16, 24, 30, 40, 42, 1H 16ST, 30ST, 34ST 40ST, 42ST	basic requirement only plus soft mallet plus $\frac{3}{8}$ " A/F Allen Key
44, 48, 44ST, 48ST	plus $\frac{7}{8}$ " or $\frac{5}{8}$ " A/F Allen Key
55, 65, 55ST, 65ST	plus $\frac{3}{8}$ " A/F Allen Key
From Dec. 1983 – 16, 24, 30, 40, 43, 46, 52, 16ST, 30ST, 40ST, 43ST, 46ST, 52ST	basic plus cross head screwdriver

## SERVICE MANUALS

A full service manual is available from your nearest Lewmar distributor office. Your dealer can supply the correct manual for your particular winch. Full servicing of any winch should not be undertaken without reference to this manual.

For models not mentioned here, please contact your Lewmar offices for service details.

### Service Manual Vol IV applies

Winch	Start	End
6, 7, 8	Jan 76	—
16, 24, 30, 40	Mar 84	—
43, 46	Jan 84	—
52	Dec 84	—
48, 55, 65	Jan 84	—
16ST, 40ST	Jan 84	—
30ST, 43ST, 46ST	Mar 83	—
48ST, 55ST, 65ST	Jan 81	—
52ST	Dec 84	—
No. 1 Halliard	Jan 78	—

### Service Manual Vol V applies

Winch	Start	End
6	Jan 83	—
7, 8	Jan 85	—
16, 24, 30, 40	May 85	—
43, 46	Mar 85	—
52	Dec 84	—
48, 55, 65	Jan 84	—
16ST, 40ST	Mar 85	—
30ST, 43ST, 46ST	Mar 85	—
48ST, 55ST, 65ST	Jan 84	—
52ST	Dec 84	—
No. 1 Halliard	Jan 78	—

### System LEWMAR

### Service Manual Vol V Specials applies

Winch	Start	End
3 speed, 3 gear 55/3, 65/3	Jan 85	—
3 speed, 3 gear 55ST, 65ST	Jan 85	—

Also coffee grinders and linkage

**SERVICE MANUAL**  
Volume 5

**SERVICE MANUAL**  
Volume 5  
Specials

**LEWMAR**

# FITTING WINCHES

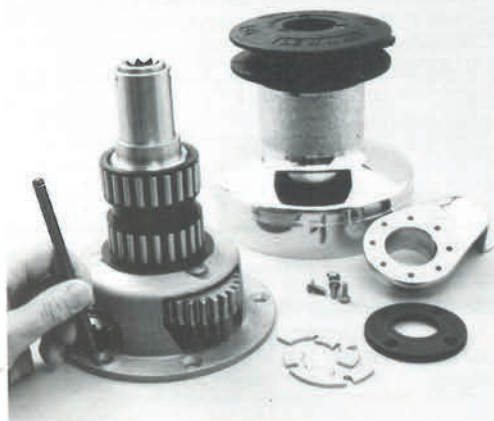

## Fitting your winch

To achieve the best bolt and output gear support to optimise performance, we suggest you fit your Lewmar winches in the following manner: -

1. Remove the drum
2. Locate the winch base to achieve the best possible bolt support (see 1,2).
3. Mark the location of the bolt holes
4. Remove the winch
5. Drill the bolt holes
6. Apply bedding compound to the underside, ensuring that each bolt is bedded but keeping the gear spindles clean
7. Bolt the winch into place, progressively tightening the bolts in a clockwise direction
8. Clean off surplus bedding compound
9. Refit the drum
10. Check that the winch is operating correctly

**Note:** Please refer to the special instructions provided with every Lewmar Self Tailing and Electric Winch. 3 speed winches are self draining, but care should be taken to ensure that the drain holes (on the underside of the base) are not blocked.

## 1 SPEED

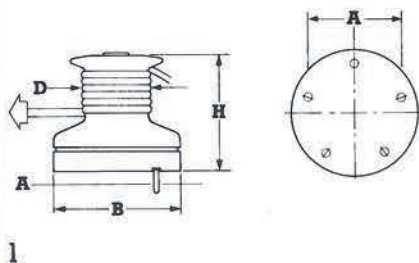

1

## 2 SPEED/3 SPEED

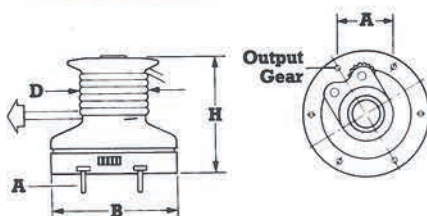

2

## ELECTRIC WINCHES

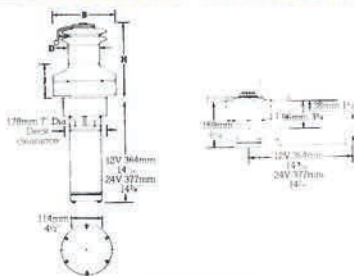

3

## HALLIARD WINCH

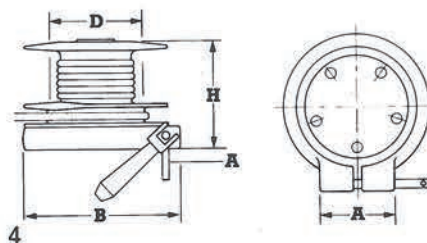

4

# USING WAVEGRIP

## Self-tailer convenience

If you've ever found yourself short of hands, space or just plain old musclepower, a couple of Lewmar self-tailing winches will make all the difference. By freeing you of the necessity to tail the sheet, a self-tailer enables you to use both hands to wind. Lewmar's patented Wavegrip concept is simple, safe and convenient.

## A closer Look: Self-tailing with Lewmar's Wavegrip®

Ever since its introduction, Lewmar's patented Wavegrip mechanism has set the world standard for self-tailing performance. Other winchmakers had been playing with brawny, rope-chewing spring-loaded jaws; typically, Lewmar engineers used brains instead.



## Self Tailers – How they work

1. The rope must be placed in the jaws correctly. The turn leading from the drum must be passed across the stripper mechanism as shown and placed into the jaws.
2. The winch must be mounted so that the loose sheet falls correctly into a secure stowage position. The position of the stripper arm can be adjusted to give correct feed off of the sheet.
3. There must be a minimum of 3 turns of rope on the barrel.
4. The jaws are designed to accept a range of rope diameters. The winch should only be used with ropes of the sizes recommended.

## Range of rope diameters

Cat. Nos.	Circumference (mm)	(ins)	Diameter (mm)	(ins)
16ST	26/45	1/1 $\frac{3}{4}$	8/14	$\frac{5}{16}$ / $\frac{9}{16}$
30ST	26/45	1/1 $\frac{3}{4}$	8/14	$\frac{5}{16}$ / $\frac{9}{16}$
40ST	32/45	1 $\frac{1}{4}$ / 1 $\frac{3}{4}$	10/14	$\frac{3}{8}$ / $\frac{9}{16}$
43ST	32/51	1 $\frac{1}{4}$ / 2	10/16	$\frac{3}{8}$ / $\frac{5}{8}$
46ST	32/51	1 $\frac{1}{4}$ / 2	10/16	$\frac{3}{8}$ / $\frac{5}{8}$
48ST	32/51	1 $\frac{1}{4}$ / 2	10/16	$\frac{3}{8}$ / $\frac{5}{8}$
52ST	38/57	1 $\frac{1}{2}$ / 2 $\frac{1}{4}$	12/18	$\frac{1}{2}$ / $\frac{3}{4}$
55ST	38/57	1 $\frac{1}{2}$ / 2 $\frac{1}{4}$	12/18	$\frac{1}{2}$ / $\frac{3}{4}$
65ST	45/64	1 $\frac{3}{4}$ / 2 $\frac{1}{2}$	14/20	$\frac{9}{16}$ / $1\frac{3}{8}$

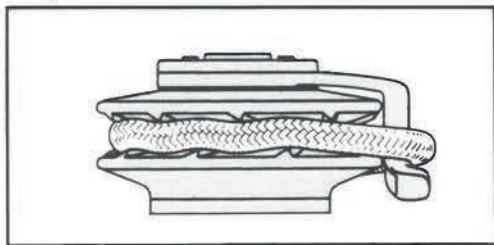

Wavegrip's carefully designed radial 'teeth', set in a wave form, takes ropes of different diameters without adjustment. Each rope finds its own optimum position and is held there, not by cumbersome spring-loaded jaws, but by the load in the line itself. The higher the load, the firmer the grip, yet releasing the rope requires little or no musclepower... just ease it out of the Wavegrip jaws.

Wavegrip handles the rope gently, so there's less wear and tear on your sheets. Another big feature: the low-friction design means you can set the winch up before you tack, and tail the first few metres of slack in by hand... through Wavegrip! Try that on any other self-tailer!

# ADJUSTING SELF TAILERS

16, 30, 40, 43, 46

48, 52, 55, 65



1

Remove 4 screws, in top cap. Remove top cap.



1

Remove 4 socket head screws with a  $\frac{3}{16}$ " A/F Allen Key. Lift off top cap.



2

Rotate stripper arm to required position, (it can be moved in  $8 \times 45^\circ$  increments, with the winch bolted in place).



2

Remove both collets. Lift off stripper arm and place in required position, ensuring that the stripper arm is placed over the stripper ring in the jaw assembly.



3

Replace top cap and screws.



3

Replace collets, top cap and screws.



# SERVICING

## Single Speed 6,7,8



1 Remove circlip with a small screwdriver or knife blade.



4 Wash centre stem, roller bearings and drum bore with kerosene (paraffin). Dry with a non-fluffy cloth.

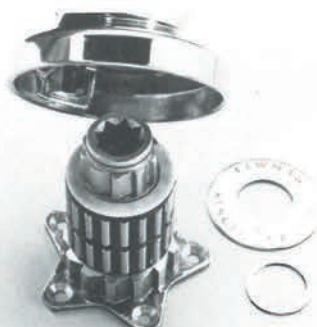

2 Lift off the drum, (Remove roller bearings and drum washer on model 8).

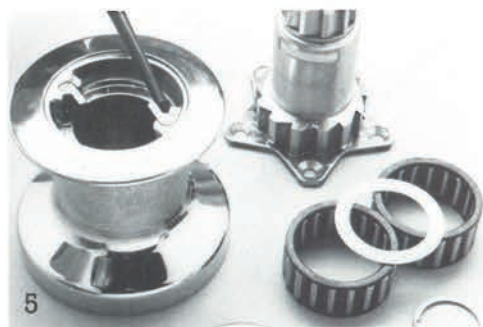

5 Oil pawls in top and bottom of the drum.



3 Ease out keyway and remove centre spindle.

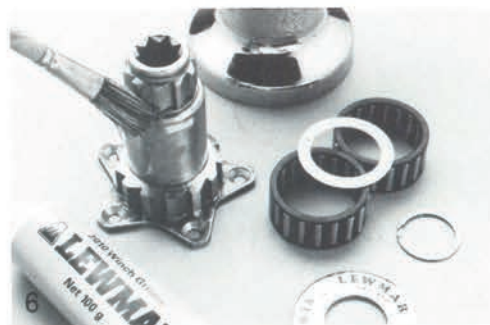

6 Grease all parts lightly (including bearings on model 8).

Reassemble winch in reverse sequence. Check for correct operation.

# SERVICING

## 2 Speed 16, 24, 30, 40



1 Remove circlip with a small screwdriver or knife blade.



4 Grease spindle and all other moving parts lightly.



2 Remove top cap, screws, crown and drum. Oil pawls in drum.



5 Remove gear spindle.



3 Remove bearings, drum washer and spindle. Clean all parts with kerosene (paraffin). Dry with a non-fluffy cloth, oil spindle pawls.



6 Remove gears, clean and oil gear pawls and lightly grease other parts.

Reassemble winch in reverse sequence. Check for correct operation.

## 2 Speed 43,46



1 Remove circlip with a small screwdriver or knife blade.

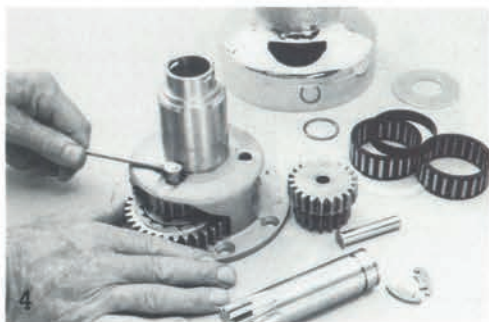

4 Lift out gear spindles and gears, wash and clean all parts.

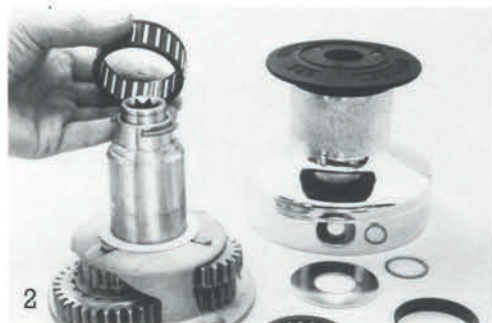

2 Remove drum, top cap and crown. Refit crown (use anti-seize on crown screws). Remove bearings and drum washer.



5 Wash, clean, grease gears, bearings and centre spindle.



3 Remove collets from top of centre stem and remove centre spindle.

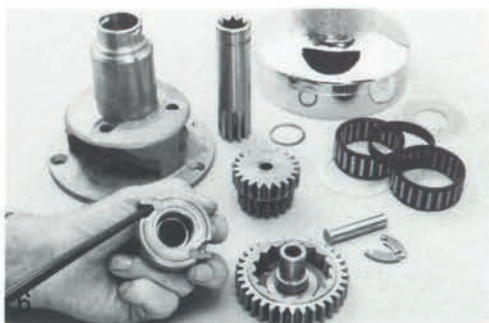

6 Oil pawls in both gears.  
Reassemble winch in reverse sequence.  
Check for correct operation.

# SERVICING

## 2 Speed 52



1 Remove circlip with a small screwdriver or knife blade. Lift off drum. Remove crown (see p. 11-2).



4 Wash, clean all parts, grease all 8 bearings and all moving parts.



2 Remove bearings and drum washer. Remove collets from top of centre stem and remove centre spindle.



5 Oil pawls in both gear sets.



12 Lift out gear spindles and gears taking care that the gear bearings don't fall out.  
Reassemble winch in reverse sequence. Check for correct operation.



When reassembling take care to place the washers on the bottom of both gear sets (see also p. 21, 6). NOTE: It may help to remove centre stem from base (3 allen screws.)

# 3 Speed 48, 55, 65 Top Action



1

## Servicing Top Cap Assembly

With drum already removed, lift off top cap assembly.



2

Remove large circlip, lift springs and remove plastic closing ring.



3

Check that closing ring and plunger pin are in good condition.

**Assembly Warning:** When reassembling pawl/ratchet gears, check for correct assembly. Look and check that the pawls seat in the matching ratchet faces.

## Servicing Ratchet Gears

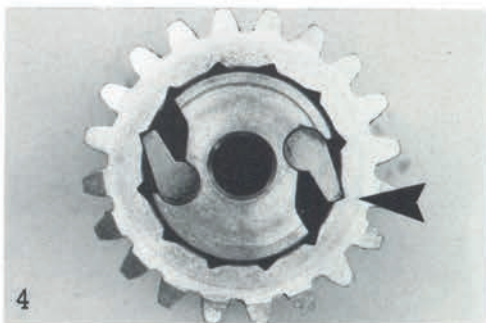

4

Correct location of ratchet gears.

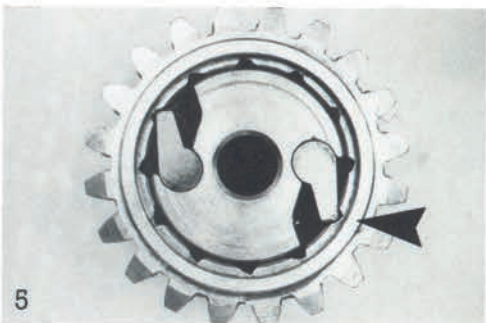

5

Incorrect location of ratchet gears.

# SERVICING

## 3 Speed 48, 55, 65 Top Action



Remove circlip with a small screwdriver or knife blade.



Remove collets from top of centre stem and lift off centre stem.

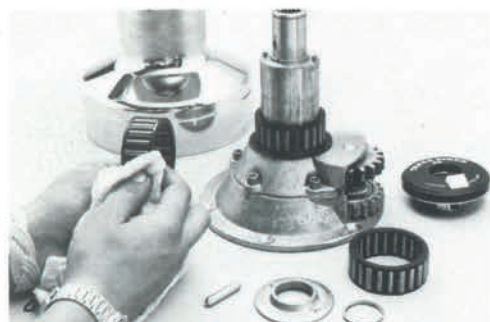

Remove drum and top cap (see p. 13, 1-3), remove cross pin and clutch plate. Remove bearings, wash, clean and grease.

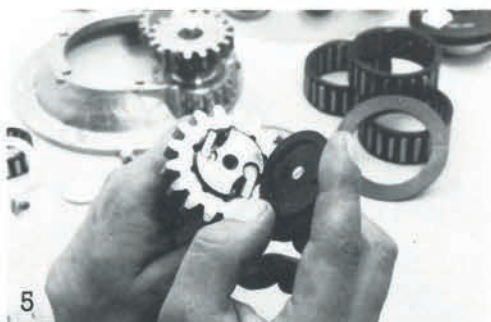

Ensure correct location of plastic end cap studs in pawl sockets.

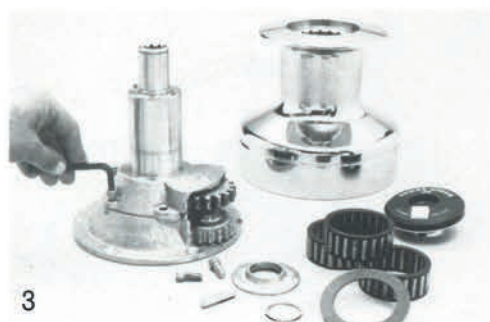

3

Remove allen screws.



6

Remove gears with bearings, clean and oil pawls, and lightly grease all moving parts.

Reassemble winch in reverse sequence. Check for correct operation. See also p. 22, 6.

14 **Warning**  
Do not drop drum onto centre stem.

# 3 Speed 48, 55, 65 Top Action

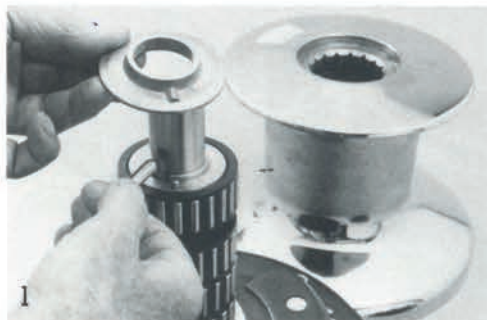

1 Remove circlip, drum and top cap assembly. Remove cross pin and clutch plate.



4 Remove each gear, wash, clean, and grease all moving parts in winch.  
NOTE: When reassembling, gear order – mid-large-small.



2 Remove bearings, spacer, drum washer. Release outer screws in base and lift out centre stem assembly.



5 Oil all pawls (including top cap – see also p. 13, 1-3), also pawls at bottom of centre spindle



3 Remove 3 inner screws in centre stem, release bridge piece (below centre stem). Remove centre spindle, complete with all bearings. Wash, clean and grease.



6 Make sure gear spindle location pins are in the correct position before fitting bridge piece to centre stem. Place main spindle onto smallest gear.

# SERVICING

## No 1 Halliard

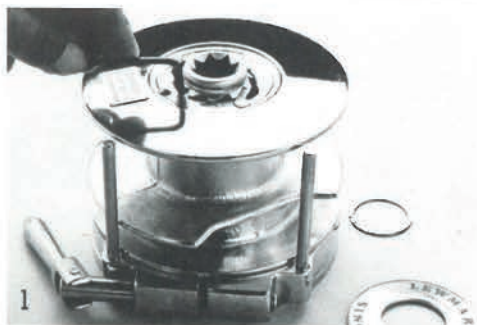

1 Remove the halliard, releasing the bitter end by unscrewing the  $2 \times \frac{1}{4}$ " UNC grub screws.

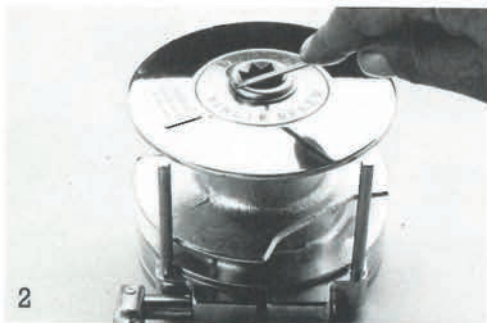

2 Remove circlip with a small screwdriver or knife blade.



3 Remove drum, clean all parts, grease bearings and drive spindle lightly.

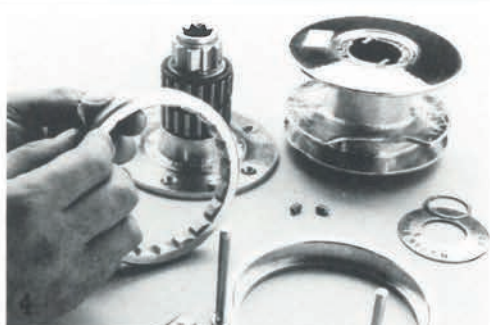

Remove brake band and ratchet ring, clean with light abrasive and wash with kerosene (paraffin). Dry with a non-fluffy cloth.

**Primary and Secondary Drums** – The main body of the halliard is stored on the primary drum and the turns should be stacked evenly. When the sail is nearly fully hoisted, i.e. within 2 or 3 feet of the black band the final turns should be wound on the secondary drum to avoid crushing the wire.

### Warning

The brake should be tightened firmly before hoisting the sail. When lowering the sail the brake is released as described and the rate of descent controlled with the brake lever. **THE HANDLE MUST NOT BE LEFT IN THE WINCH WHEN THE BRAKE IS RELEASED AS IT WILL REVOLVE. THIS IS DANGEROUS AND CAN CAUSE INJURY. OIL OR GREASE MUST NOT BE APPLIED TO THE BRAKE MECHANISM ON ANY HALLIARD WINCH.**

### NOTE:

When reassembling, ensure pawls engage correctly into ratchet ring.

**Reassemble winch in reverse sequence. Check for correct operation.**



# Single Speed 16ST

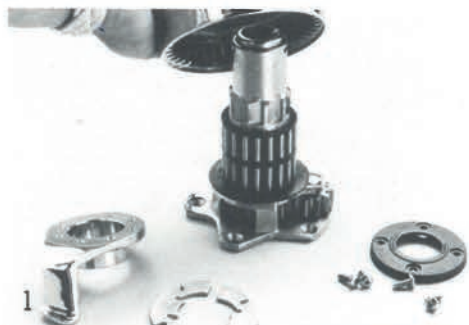

1 Remove top cap, collets, stripper arm and drum.



4 Remove gear spindle, output gear and drive gear. Wash and clean.

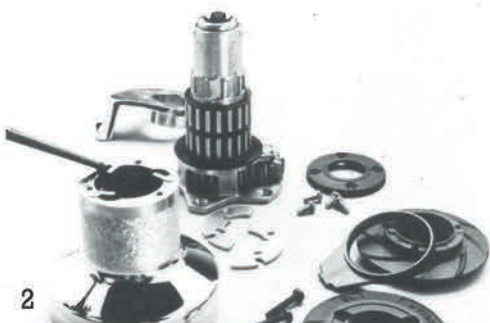

2 Remove self tailing jaw assembly, clean all parts, oil pawls in drum and refit.

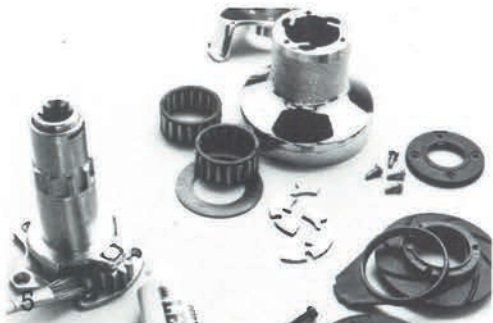

5 Start to reassemble. Grease all moving parts lightly and oil pawls in main spindle. Replace bearings and drum.

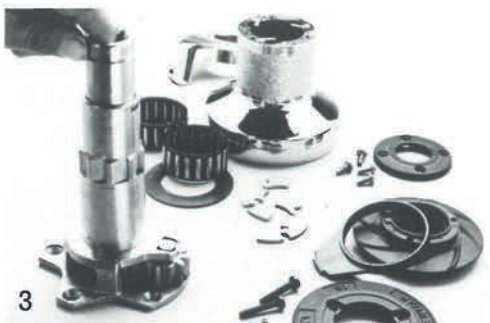

3 Remove bearings, drum washer and spindle, wash and clean all parts.

**Reassemble winch in reverse sequence. Check for correct operation.**



6 Make sure stripper arm is over stripper ring in jaw assembly (see p.19, 6). Replace collets by lifting centre spindle. Replace top cap and screws.

# SERVICING

## 2 Speed 30ST, 40ST



1 Remove 4 screws in top cap. Remove top cap.



4 Lift out gear spindles, remove gears. Wash, clean and grease the gears.

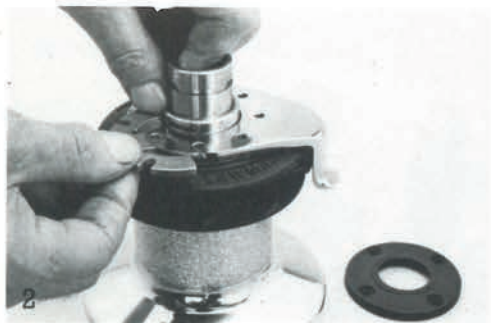

2 Remove collets, lift out centre spindle.



5 Oil all pawls.



3 Remove stripper arm, drum. Release self tailing jaw assembly. Clean and refit. Remove bearings and drum washer. Wash, clean and grease bearings. Reassemble winch in reverse sequence.

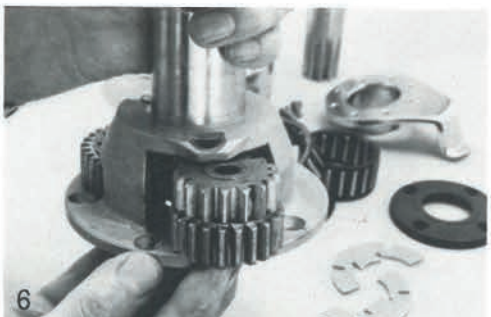

6 When reassembling take care that 'small' gear is on top (see pic) and stripper arm is over stripper ring in jaw assembly (see p. 19, 6). Check for correct operation.

# 2 Speed 43ST, 46ST



1 Remove 4 screws in top cap. Remove top cap.



Lift out gear spindles, remove gears. Wash, clean and grease the gears.

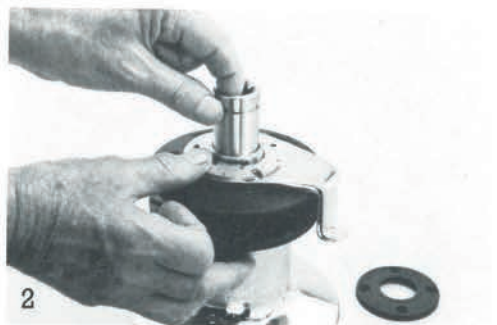

2 Remove collets, lift out centre spindle.

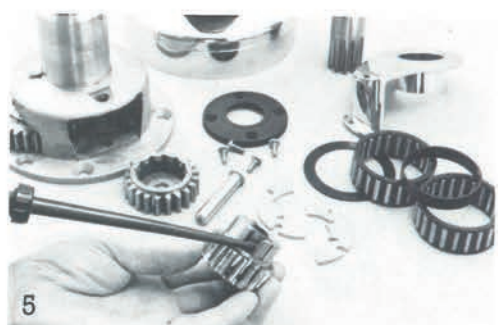

5 Oil all pawls.



3 Remove stripper arm, drum. Release self tailing jaw assembly, clean and refit. Remove bearings and drum washer. Wash, clean and grease bearings.



6 When reassembling take care that stripper arm is over stripper ring in jaw assembly. Reassemble winch in reverse sequence. Check for correct operation.

# SERVICING

## 2 Speed 48ST



1 Remove 4 screws in top cap ( $\frac{3}{16}$ " A/F Allen Key). Remove top cap.



4 Lift off centre stem upper. Remove centre spindle, unscrew plastic end cap and oil pawls at end of centre spindle.



2 Remove stripper arm. Lift off drum assembly, release self tailing jaw assembly, clean and refit. Remove bearings and drum washer. Wash, clean and grease bearings.

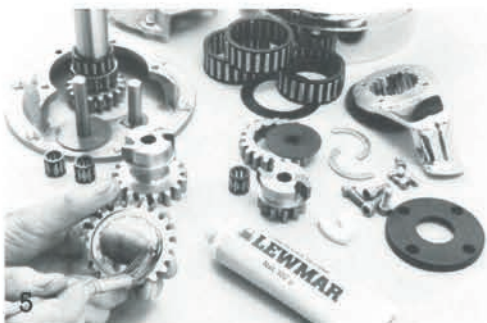

5 Remove gears, oil pawls, grease all moving parts. When reassembling carefully locate centre spindle in gears before replacing centre stem upper.



3 Remove allen screws in centre stem. Ease out plastic key.

### Assembly Warning

When reassembling pawl/ratchet gears ensure correct assembly. Look and check that pawls seat in the matching ratchet faces (see also p. 13, 4-5).

Reassemble winch in reverse sequence. Make sure stripper arm is over stripper ring in jaw assembly (see p. 19, 6). Check for correct operation.

# 2 Speed 52ST



**1**  
Remove 4 screws in top cap ( $\frac{3}{16}$ " A/F Allen Key). Remove top cap.

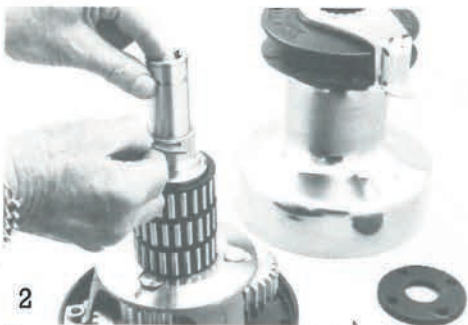

**2**  
Remove stripper arm. Lift off drum assembly, release self tailing jaw assembly, clean and refit. Remove collets and lift out centre spindle.

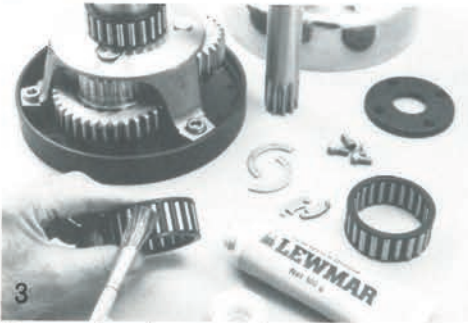

**3**  
Remove bearings and drum washer. Wash, clean and grease bearings.

**Reassemble winch in reverse sequence. Check for correct operation.**

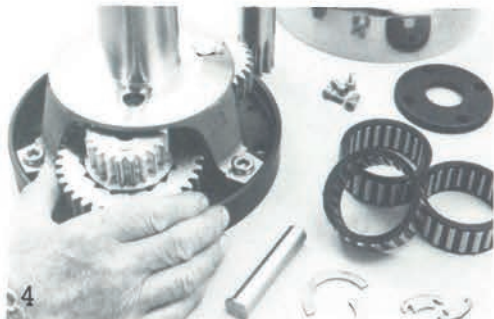

**4**  
Lift out gear spindles and gears taking care that the gear bearings don't fall out.

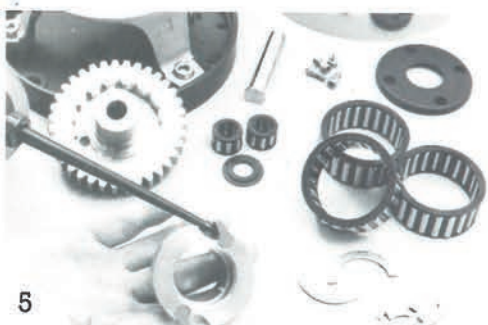

**5**  
Oil pawls in both gear sets.

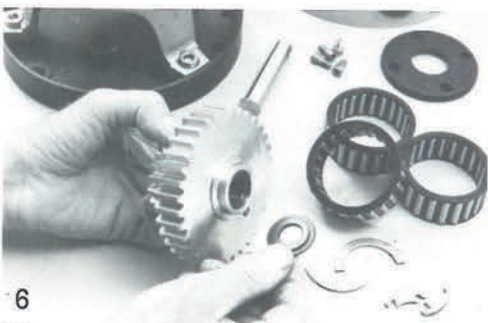

**6**  
When reassembling take care to place the washers on the bottom of both gear sets and that stripper arm is over stripper ring in jaw assembly (see p. 12-6 and p. 19-6).

# SERVICING

## 2 Speed 55ST, 65ST



1 Remove 4 screws in top cap ( $\frac{3}{16}$ " A/F Allen Key). Remove top cap.



2 Remove collets, stripper arm. Lift off drum assembly, releasing self tailing jaw assembly, clean and refit.

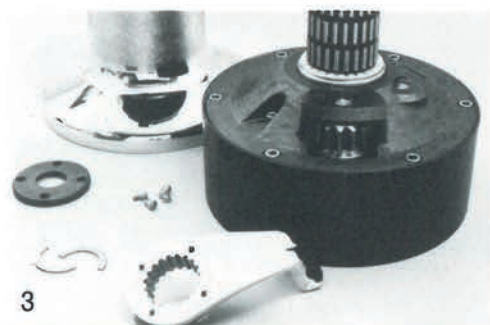

3 Remove bearings, spacer, drum washer. Release outer screws in base and lift out centre stem assembly.



4 Remove 3 inner screws in centre stem, release bridge piece (below centre stem). Remove centre spindle, complete with bearings. Wash, clean and grease.

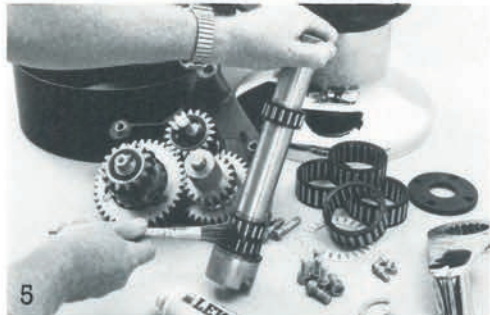

5 Proceed and read p. 15, 4-6, p. 19, 6.

### Warning

The winch is self draining, but care should be taken to ensure that the drain holes (on the underside of the base) are not blocked.

Do not drop drum onto centre stem.

Reassemble winch in reverse sequence. Check for correct operation.

# 3 Speed 55/3, 65/3, 55/3ST, 65/3ST



**1**  
General service as described on p. 15, 1-6 and p. 22, 1-6. (For adjustment ease plastic cover off bottom push button (in base) with a small screwdriver). \*see 6.

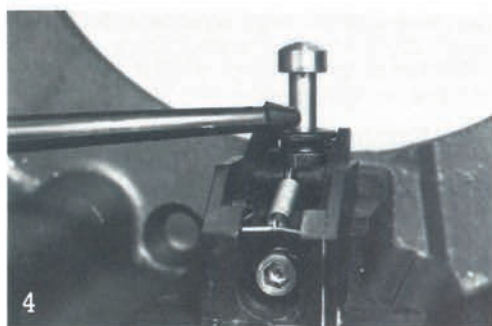

**4**  
Plunger shown in engaged position. Oil and work plunger so that oil migrates and smooth action results.

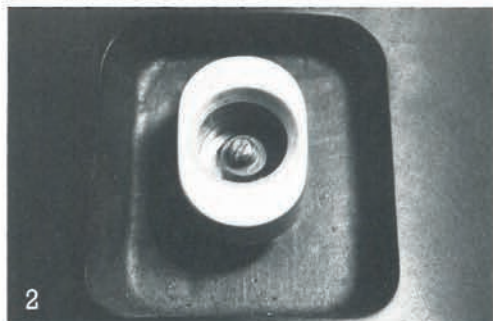

**2**  
Close up showing nut and screw. Plunger is adjusted to effect smooth gear selection. (If in doubt contact nearest Lewmar office).



**5**  
When reassembling complete centre stem to base. The gear change fork (indicated) must line up with the plunger when the plunger is disengaged.

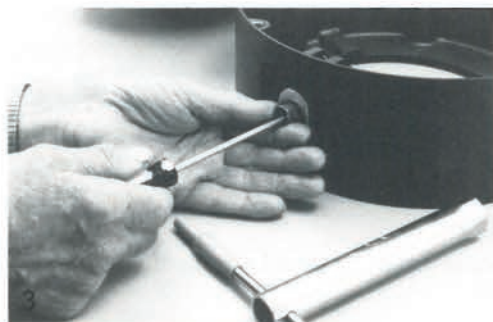

**3**  
Adjustment and locking of plunger assembly using box spanner and screwdriver. Tighten nut without moving screw position.

## Warning

The winch is self draining, but care should be taken to ensure that the drain holes (on the underside of the base) are not blocked.

**Do not drop drum onto centre stem.**

\*If gear change works smoothly leave alone and proceed to 4.

**6**

Reassemble winch in reverse sequence. Check for correct operation.

# SERVICING

## Electric Winches

For general servicing instructions, follow pages 20, 22 and 23. For specific problems, follow the chart below, or contact your nearest Lewmar office.

### Fault Finding Guide

Symptom	Probable Cause	Remedy
Winch works only in one speed	Motor polarity	Check wiring polarity to motor and reverse if necessary
Winch does not work at all	a. Bad connection	Check all wiring connections especially to battery
	b. Blown fuse or circuit breaker	Check circuit breaker
		Check fuse on encapsulated PC board and replace if blown
		NOTE: Do not alter or interfere with sealed trimmer
		If fuse blows again immediately – contact your Lewmar Agent
c. Micro-switch in control unit not operating	Check that air switch bellow is operating the micro-switch in control unit	
	Adjust for sensitivity if necessary	
d. Insufficient power	Check battery for charge	
e. Worn brushes or brush hung up	Check brushes and commutator on motor and release or replace if necessary	

#### NOTE:

If the winch requires further servicing, please contact your nearest Lewmar office.





# YOUR LEWMAR GUARANTEE.

## Guarantee Counterfoil

The following particulars will be registered under the terms of our guarantee.

Name \_\_\_\_\_

Address \_\_\_\_\_  
\_\_\_\_\_  
\_\_\_\_\_

Boat Type \_\_\_\_\_

LOA \_\_\_\_\_

Built by \_\_\_\_\_

### Winches

Model \_\_\_\_\_

Model \_\_\_\_\_

Model \_\_\_\_\_

Model \_\_\_\_\_

Model \_\_\_\_\_

Model \_\_\_\_\_

### Winches Supplied (Please tick)

- came with boat
- fitted by boatyard/dealer
- purchased form dealer/chandler

Date \_\_\_\_\_

# YOUR LEWMAR GUARANTEE.

The following particulars will be registered under the terms of our guarantee.

Name \_\_\_\_\_

Address \_\_\_\_\_  
\_\_\_\_\_  
\_\_\_\_\_

Boat Type \_\_\_\_\_

LOA \_\_\_\_\_

Built by \_\_\_\_\_

### Winches

Model \_\_\_\_\_

Model \_\_\_\_\_

Model \_\_\_\_\_

Model \_\_\_\_\_

Model \_\_\_\_\_

Model \_\_\_\_\_

### Winches Supplied (Please tick)

- came with boat
- fitted by boatyard/dealer
- purchased form dealer/chandler

Please complete reverse also

Date \_\_\_\_\_



NOTE  
Please return to your nearest Lewmar  
office – shown overleaf

# FURTHER INFORMATION

I am interested to receive more details of System Lewmar to compliment my Winches. Please send me details and brochures, as shown on the back page.

- Deck Hardware
- Super Hatch
- Winches
- Performance Winches
- Service Manual IV
- Service Manual V
- Service Manual V Specials
- Navtec Rigging
- Navtec Hydraulics
- Commander Hydraulic Power Packs
- Portlight
- New Products
- Newsletter
- Ball Bearing Handles
- Performance Deck Hardware
- Self Tailing Winches

## Lewmar Subsidiary Companies, Regional Distributors and Distributors/Service Centres in the USA

### LEWMAR

#### Head Office:-

Lewmar Marine Limited  
Southmoor Lane, Havant  
Hampshire PO9 1JJ, England  
tel: Havant (0705) 471841-3  
tx: 86342 LEWMAR G

#### Subsidiaries:-

Lewmar Sud Europe SARL  
Avenue Louis Lumiere  
ZI de Persigny  
17000 La Rochelle, France  
tel: (46) 44 4944  
tx: 792202 YACHTEO F

Lewmar Marine Inc. (East Coast)  
23 Broad Common Road, Bristol  
Rhode Island 02809, USA  
tel: (401) 253 5200  
tx: 7103871155 LEWMAR BROL

Lewmar Marine Inc. (West Coast)  
876 West 16th Street  
Newport Beach, California 92663  
USA  
tel: (714) 631 7255  
tx: 6836047 LMRWC

Lewmar Marin AB  
Box 5073, S-172 06 Sundbyberg  
Sweden  
tel: (08) 98 04 75  
tx: 15184 LEWMAR S

Lewmar Marine Limited  
1410 Speers Road, No. 2 Oakville  
Ontario, Canada L6L 5M1  
tel: (416) 827 8910  
tx: 06992257 LEWMAR CDA OKVL

#### Lewmar World Service

Full service care, spare parts  
and assistance are available  
worldwide. In case of any  
difficulty please contact your  
nearest Lewmar office or  
distributor.

#### Regional Distributors:

##### UK

Marinac Yacht Fittings Limited  
Glasgow G51 3TR  
tel: 041 810 4848

##### X-M Yachting

Polegate, East Sussex  
tel: 0323 870092  
tx: 878144 XMYOTS G

##### Yacht Tests Limited

Burnham on Crouch, Essex  
tel: 0621 782235  
tx: 995494 YOTEST G

##### ARGENTINA

Delta Finn Marine SRL  
Prov. de Buenos Aires  
tel: 745 3567  
tx: 26282 CAMOU AR

##### Navitronic

Buenos Aires  
tel:  
tx: 26085 NAVI AR

##### AUSTRALIA

Warwick Hoban & Associates  
Brighton Beach  
Victoria 3186  
tel: (03) 592 7077  
tx: 38077 YACHT AA

##### AUSTRIA/EASTERN EUROPE

##### Horst Welebn

A 4020 Linz  
tel: (732) 42666/7  
tx: 22276 WELEBN A

##### BRAZIL

O. Veleiro Importacao  
E Exportacao Ltda  
Rio de Janeiro  
tel: (21) 233 3275/3025  
tx: 2130126 VIEX BR

##### CANARIES ISLAND

Nordest  
Santa Cruz de Tenerife  
tel: 922284871  
tx: 92230

##### CHILE

AMF Astilleros  
Santiago  
tel: 2212571/2212116  
tx: 340976 AMFSA CK

##### CYPRUS

Mercury Divers Co. Ltd.  
Limassol  
tel: 051-55492  
tx: 4976 MERC DIVE CY

##### DENMARK

Munter Marine A/S  
Copenhagen  
tel: (01) 37 66 00  
tx: 27591 DOMION DK

##### CARIBBEAN

Hi-Tech Caribbean Ltd  
Tortola, BVI  
tel: 809-494-3811  
tx: 7969 HDSAIL VB

##### Goodwood Marine

Trinidad, West Indies  
tel: 83-24612  
tx: 276 FITWIR WG

##### Ship Shop Martinique

Martinique  
tel: 97200  
tx: 912302

##### FINLAND

Oy Vestek AB  
Espoo  
tel: (90) 460 344  
tx: 121269 VSTEK SF

##### GERMANY

Martin Hohorst  
Bremen 77  
tel: (0421) 63 00 85  
tx: 245924 MAROS D

##### GIBRALTAR

H. Sheppard and Co. Ltd.  
Waterport  
tel: (350) 77183  
tx: 2324 MARINA GX

##### GREECE

Jordan P. Pilidis  
Piraeus  
tel: (1) 4521647  
tx: 211082 TPI GR

##### HOLLAND/BELGIUM/ LUXEMBOURG

Marquip BV  
Vollenhove, Netherlands  
tel: (065274) 3500  
tx: 42937 MARQU NL

##### HONG KONG

Far East Yacht Specialists Limited  
Hong Kong  
tel: 5-229394/5-226752  
tx: 65925 KREMA HX

##### ITALY

Deck Marine  
Milano  
tel: (02) 3087226/3080631  
tx: 330569 YACHT I

##### JAPAN

Nakamura Sengu Kogyo Co. Ltd.  
Yokohama  
tel: (45) 68 10 94  
tx: 3822853 REPRO J

##### KOREA

Dong Jin Trading Corporation  
Seoul  
tel: 447 9067-8-9  
tx: K25698 BESTOH

##### MALTA

Ripard, Larvan and Ripard Ltd.  
tel: Ozira 31583  
tx: 994 YOTS MW



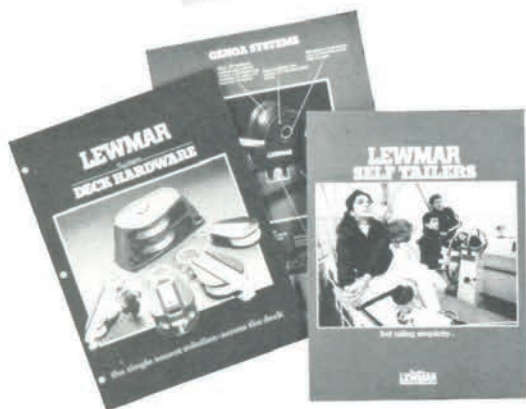

The range of catalogues available from your dealer, indicate on your guarantee card if you would like to receive your copy direct, or more information on other Lewmar products.



Distributed by:—

All rights reserved  
 Copyright Lewmar Marine Ltd., 1986  
 Printed in England  
 Produced by  
 Owen Print and Graphic Ltd., Havant  
 Code No. LHT6