



# **SERVICE MANUAL**

## **44A-44B-44C-FOUR**

## **35C-35D-35E-THREE**

### **MARINE DIESEL ENGINES**

<b>8.0KW - 60Hz</b>	<b>6.0KW - 50Hz BTDA</b>
<b>10.0KW - 60Hz</b>	<b>7.5KW - 50Hz BTDA</b>
<b>11.5KW - 60Hz</b>	<b>9.2KW - 50Hz BTD (elec)</b>
<b>12.5KW - 60Hz</b>	<b>9.4KW - 50Hz BTDB</b>
<b>12.6KW - 60Hz</b>	<b>10.4KW - 50Hz BTD (elec)</b>
<b>15.0KW - 60Hz</b>	<b>12.0KW - 50Hz BTDC</b>

### **Single and Three Phase**

## **MARINE DIESEL GENERATORS**

PUBLICATION NO.45100  
REVISION 2  
APRIL 2010



WESTERBEKE CORPORATION • 150 JOHN HANCOCK ROAD  
MYLES STANDISH INDUSTRIAL PARK • TAUNTON MA 02780  
WEBSITE: [WWW.WESTERBEKE.COM](http://WWW.WESTERBEKE.COM)

**CALIFORNIA  
PROPOSITION 65 WARNING**

Diesel engine exhaust and some of its constituents are known to the State of California to cause cancer, birth defects, and other reproductive harm.

**⚠ WARNING:**

*Exhaust gasses contain Carbon Monoxide, an odorless and colorless gas. Carbon Monoxide is poisonous and can cause unconsciousness and death. Symptoms of Carbon Monoxide exposure can include:*

- *Dizziness*
- *Throbbing in Temples*
- *Nausea*
- *Muscular Twitching*
- *Headache*
- *Vomiting*
- *Weakness and Sleepiness*
- *Inability to Think Coherently*

***IF YOU OR ANYONE ELSE EXPERIENCE ANY OF THESE SYMPTOMS, GET OUT INTO THE FRESH AIR IMMEDIATELY. If symptoms persist, seek medical attention. Shut down the unit and do not restart until it has been inspected and repaired.***

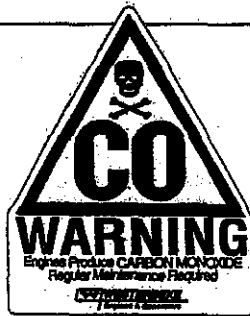

***This WARNING DECAL is provided by WESTERBEKE and should be fixed to a bulkhead near your engine or generator.***

***WESTERBEKE also recommends installing CARBON MONOXIDE DETECTORS in the living/sleeping quarters of your vessel. They are inexpensive and easily obtainable at your local marine store.***

# SAFETY INSTRUCTIONS

## INTRODUCTION

*Read this safety manual carefully. Most accidents are caused by failure to follow fundamental rules and precautions. Know when dangerous conditions exist and take the necessary precautions to protect yourself, your personnel, and your machinery.*

*The following safety instructions are in compliance with the American Boat and Yacht Council (ABYC) standards.*

## PREVENT ELECTRIC SHOCK

**⚠ WARNING: Do not touch AC electrical connections while engine is running, or when connected to shore power. Lethal voltage is present at these connections!**

- Do not operate this machinery without electrical enclosures and covers in place.
- Shut off electrical power before accessing electrical equipment.
- Use insulated mats whenever working on electrical equipment.
- Make sure your clothing and skin are dry, not damp (particularly shoes) when handling electrical equipment.
- Remove wristwatch and all jewelry when working on electrical equipment.
- Do not connect utility shore power to vessel's AC circuits, except through a ship-to-shore double throw transfer switch. Damage to vessel's AC generator may result if this procedure is not followed.
- Electrical shock results from handling a charged capacitor. Discharge capacitor by shorting terminals together.

## PREVENT BURNS — HOT ENGINE

**⚠ WARNING: Do not touch hot engine parts or exhaust system components. A running engine gets very hot!**

- Always check the engine coolant level at the coolant recovery tank.

**⚠ WARNING: Steam can cause injury or death!**

- In case of an engine overheat, allow the engine to cool before touching the engine or checking the coolant.

## PREVENT BURNS — FIRE

**⚠ WARNING: Fire can cause injury or death!**

- Prevent flash fires. Do not smoke or permit flames or sparks to occur near the carburetor, fuel line, filter, fuel pump, or other potential sources of spilled fuel or fuel vapors. Use a suitable container to catch all fuel when removing the fuel line, carburetor, or fuel filters.
- Do not operate with a Coast Guard Approved flame arrester removed. Backfire can cause severe injury or death.
- Do not operate with the air cleaner/silencer removed. Backfire can cause severe injury or death.
- Do not smoke or permit flames or sparks to occur near the fuel system. Keep the compartment and the engine/generator clean and free of debris to minimize the chances of fire. Wipe up all spilled fuel and engine oil.
- Be aware — diesel fuel will burn.

## PREVENT BURNS — EXPLOSION

**⚠ WARNING: Explosions from fuel vapors can cause injury or death!**

- Follow re-fueling safety instructions. Keep the vessel's hatches closed when fueling. Open and ventilate cabin after fueling. Check below for fumes/vapor before running the blower. Run the blower for four minutes before starting your engine.
- All fuel vapors are highly explosive. Use extreme care when handling and storing fuels. Store fuel in a well-ventilated area away from spark-producing equipment and out of the reach of children.
- Do not fill the fuel tank(s) while the engine is running.
- Shut off the fuel service valve at the engine when servicing the fuel system. Take care in catching any fuel that might spill. DO NOT allow any smoking, open flames, or other sources of fire near the fuel system or engine when servicing. Ensure proper ventilation exists when servicing the fuel system.
- Do not alter or modify the fuel system.
- Be sure all fuel supplies have a positive shutoff valve.
- Be certain fuel line fittings are adequately tightened and free of leaks.
- Make sure a fire extinguisher is installed nearby and is properly maintained. Be familiar with its proper use. Extinguishers rated ABC by the NFPA are appropriate for all applications encountered in this environment.

# SAFETY INSTRUCTIONS

## ACCIDENTAL STARTING

**⚠ WARNING: Accidental starting can cause injury or death!**

- Disconnect the battery cables before servicing the engine/generator. Remove the negative lead first and reconnect it last.
- Make certain all personnel are clear of the engine before starting.
- Make certain all covers, guards, and hatches are re-installed before starting the engine.

## BATTERY EXPLOSION

**⚠ WARNING: Battery explosion can cause injury or death!**

- Do not smoke or allow an open flame near the battery being serviced. Lead acid batteries emit hydrogen, a highly explosive gas, which can be ignited by electrical arcing or by lit tobacco products. Shut off all electrical equipment in the vicinity to prevent electrical arcing during servicing.
- Never connect the negative (-) battery cable to the positive (+) connection terminal of the starter solenoid. Do not test the battery condition by shorting the terminals together. Sparks could ignite battery gases or fuel vapors. Ventilate any compartment containing batteries to prevent accumulation of explosive gases. To avoid sparks, do not disturb the battery charger connections while the battery is being charged.
- Avoid contacting the terminals with tools, etc., to prevent burns or sparks that could cause an explosion. Remove wristwatch, rings, and any other jewelry before handling the battery.
- Always turn the battery charger off before disconnecting the battery connections. Remove the negative lead first and reconnect it last when disconnecting the battery.

## BATTERY ACID

**⚠ WARNING: Sulfuric acid in batteries can cause severe injury or death!**

- When servicing the battery or checking the electrolyte level, wear rubber gloves, a rubber apron, and eye protection. Batteries contain sulfuric acid which is destructive. If it comes in contact with your skin, wash it off at once with water. Acid may splash on the skin or into the eyes inadvertently when removing electrolyte caps.

## TOXIC EXHAUST GASES

**⚠ WARNING: Carbon monoxide (CO) is a deadly gas!**

- Ensure that the exhaust system is adequate to expel gases discharged from the engine. Check the exhaust system regularly for leaks and make sure the exhaust manifolds are securely attached and no warping exists. Pay close attention to the manifold, water injection elbow, and exhaust pipe nipple.
- Be sure the unit and its surroundings are well ventilated.
- In addition to routine inspection of the exhaust system, install a carbon monoxide detector. Consult your boat builder or dealer for installation of approved detectors.
- For additional information refer to ABYC T-22 (educational information on Carbon Monoxide).

**⚠ WARNING: Carbon monoxide (CO) is an invisible odorless gas. Inhalation produces flu-like symptoms, nausea or death!**

- Do not use copper tubing in diesel exhaust systems. Diesel fumes can rapidly destroy copper tubing in exhaust systems. Exhaust sulfur causes rapid deterioration of copper tubing resulting in exhaust/water leakage.
- Do not install exhaust outlet where exhaust can be drawn through portholes, vents, or air conditioners. If the engine exhaust discharge outlet is near the waterline, water could enter the exhaust discharge outlet and close or restrict the flow of exhaust. Avoid overloading the craft.
- Although diesel engine exhaust gases are not as toxic as exhaust fumes from gasoline engines, carbon monoxide gas is present in diesel exhaust fumes. Some of the symptoms or signs of carbon monoxide inhalation or poisoning are:
  - Vomiting
  - Dizziness
  - Throbbing in temples
  - Muscular twitching
  - Intense headache
  - Weakness and sleepiness

## AVOID MOVING PARTS

**⚠ WARNING: Rotating parts can cause injury or death!**

- Do not service the engine while it is running. If a situation arises in which it is absolutely necessary to make operating adjustments, use extreme care to avoid touching moving parts and hot exhaust system components.

# SAFETY INSTRUCTIONS

- Do not wear loose clothing or jewelry when servicing equipment; tie back long hair and avoid wearing loose jackets, shirts, sleeves, rings, necklaces or bracelets that could be caught in moving parts.
- Make sure all attaching hardware is properly tightened. Keep protective shields and guards in their respective places at all times.
- Do not check fluid levels or the drive belt's tension while the engine is operating.
- Stay clear of the drive shaft and the transmission coupling when the engine is running; hair and clothing can easily be caught in these rotating parts.

## HAZARDOUS NOISE

 **WARNING:** *High noise levels can cause hearing loss!*

- Never operate an engine without its muffler installed.
- Do not run an engine with the air intake (silencer) removed.
- Do not run engines for long periods with their enclosures open.

 **WARNING:** *Do not work on machinery when you are mentally or physically incapacitated by fatigue!*

## OPERATORS MANUAL

Many of the preceding safety tips and warnings are repeated in your Operators Manual along with other cautions and notes to highlight critical information. Read your manual carefully, maintain your equipment, and follow all safety procedures.

## ENGINE INSTALLATIONS

Preparations to install an engine should begin with a thorough examination of the American Boat and Yacht Council's (ABYC) standards. These standards are a combination of sources including the USCG and the NFPA.

Sections of the ABYC standards of particular interest are:

- H-2 Ventilation
- P-1 Exhaust systems
- P-4 Inboard engines
- E-9 DC Electrical systems

All installations must comply with the Federal Code of Regulations (FCR).

## ABYC, NFPA AND USCG PUBLICATIONS FOR INSTALLING DIESEL ENGINES

Read the following ABYC, NFPA and USCG publications for safety codes and standards. Follow their recommendations when installing your engine.

**ABYC** (American Boat and Yacht Council)  
"Safety Standards for Small Craft"

Order from:

ABYC  
3069 Solomon's Island Rd.  
Edgewater, MD 21037

**NFPA** (National Fire Protection Association)  
"Fire Protection Standard for Motor Craft"

Order from:

NFPA  
11 Tracy Drive  
Avon Industrial Park  
Avon, MA 02322

**USCG** (United States Coast Guard)  
"USCG 33CFR183"

Order from:

U.S. Government Printing Office  
Washington, D.C. 20404

# INSTALLATION

When installing WESTERBEKE engines and generators it is important that strict attention be paid to the following information:

## CODES AND REGULATIONS

Strict federal regulations, ABYC guidelines, and safety codes must be complied with when installing engines and generators in a marine environment.

## SIPHON-BREAK

For installations where the exhaust manifold/water injected exhaust elbow is close to or will be below the vessel's waterline, provisions must be made to install a siphon-break in the raw water supply hose to the exhaust elbow. This hose must be looped a minimum of 20" above the vessel's waterline. *Failure to use a siphon-break when the exhaust manifold injection port is at or below the load waterline will result in raw water damage to the engine and possible flooding of the boat.*

If you have any doubt about the position of the water-injected exhaust elbow relative to the vessel's waterline under the vessel's various operating conditions, *install a siphon-break.*

**NOTE:** *A siphon-break requires periodic inspection and cleaning to ensure proper operation. Failure to properly maintain a siphon-break can result in catastrophic engine damage. Consult the siphon-break manufacturer for proper maintenance.*

## EXHAUST SYSTEM

The exhaust hose must be certified for marine use. The system must be designed to prevent water from entering the exhaust under any sea conditions and at any angle of the vessel's hull.

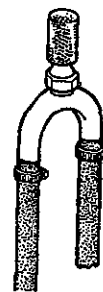

AVAILABLE FROM  
YOUR WESTERBEKE  
DEALER

**A detailed Marine Installation Manual covering gasoline and diesel engines and generators is supplied with every unit sold. This manual is also available in pdf format on our website to download**

**Website: [www.westerbeke.com](http://www.westerbeke.com)**

# TABLE OF CONTENTS

<b>Parts Identification/Engines</b> .....	2	<b>Wiring Schematic - Engines</b> .....	59
<b>Parts Identification/Generators</b> .....	3	<b>Specifications - 44-Four Models</b> .....	60
<b>Introduction</b> .....	4	<b>Specifications - 35-Three Models</b> .....	61
<b>Engine Troubleshooting</b> .....	5	<b>DC Electrical System (Alternator)</b> .....	62
<b>Testing for Overhaul</b> .....	9	<b>Mando Alternator Service</b> .....	64
<b>Engine Disassembly</b> .....	10	<b>Wiring Diagram - Generators</b> .....	71
<b>Inspection</b> .....	16	<b>Wiring Schematic - Generators</b> .....	71a
<b>Assembly</b> .....	27	<b>Remote Panel Schematic</b> .....	72
<b>Exhaust Manifold/Heat Exchanger</b> .....	35	<b>Specifications - Generators</b> .....	73
<b>Fuel Injection Pump</b> .....	36	<b>BT Generator Single/Three Phase</b> .....	76
<b>Governor</b> .....	38	12 Stud Internal Wiring Schematic.....	77
<b>Fuel Injection Timing</b> .....	39	Component Resistance Values.....	77
<b>Glow Plug Testing</b> .....	41	Internal Wiring Schematic 6 Stud.....	78
<b>Starter Motor</b> .....	42	<b>BT Generator Troubleshooting (Chart)</b> .....	79
<b>Raw Water Pumps</b>		<b>BT Generator Troubleshooting</b> .....	80
#33636.....	46	<b>BT Generator Troubleshooting (Single Phase)</b> .....	81
#48080.....	47	<b>AC Terminal Board (12 Stud)</b> .....	85
#48080 Parts List.....	48	<b>BT Internal Wiring (Three Phase)</b> .....	86
<b>Engine Adjustments</b> .....	49	<b>BT Troubleshooting (Three Phase)</b> .....	87
Valve Clearance Adjustment.....	49	<b>BT Voltage Regulator Adjustments (Three Phase)</b> .....	88
Testing Engine Compression.....	50	<b>Wiring Diagram - Generator (Electronic Governor)</b> .....	89
Generator Frequency Adjustment.....	51	<b>Wiring Schematic - Generator (Electronic Governor)</b> .....	90
Fuel Run Solenoid.....	51	<b>Electronic Governor (Optional)</b> .....	91
Oil Pressure.....	52	<b>Electronic Governor (Adjustments)</b> .....	92
Drive Belt Adjustment.....	53	<b>Linear Actuator Troubleshooting</b> .....	93
Adjusting Idle Speed.....	53	<b>Special Tools - Generator</b> .....	94
<b>Service Data-Standards and Limits</b> .....	54	<b>Standard Hardware</b> .....	95
<b>Special Tools - Engines</b> .....	56	<b>Metric Conversion Data</b> .....	96
<b>Torque Specifications</b> .....	57	<b>Index</b> .....	98
<b>Wiring Diagram - Engines</b> .....	58		

# PARTS IDENTIFICATION/PROPULSION

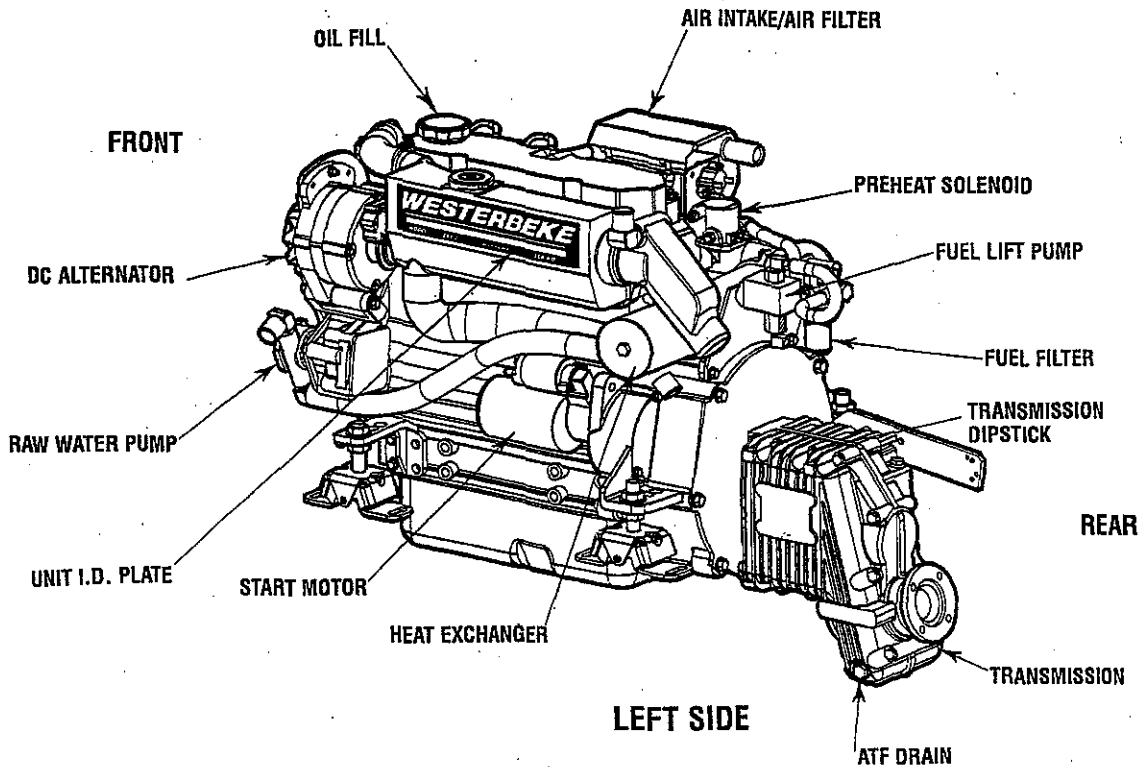
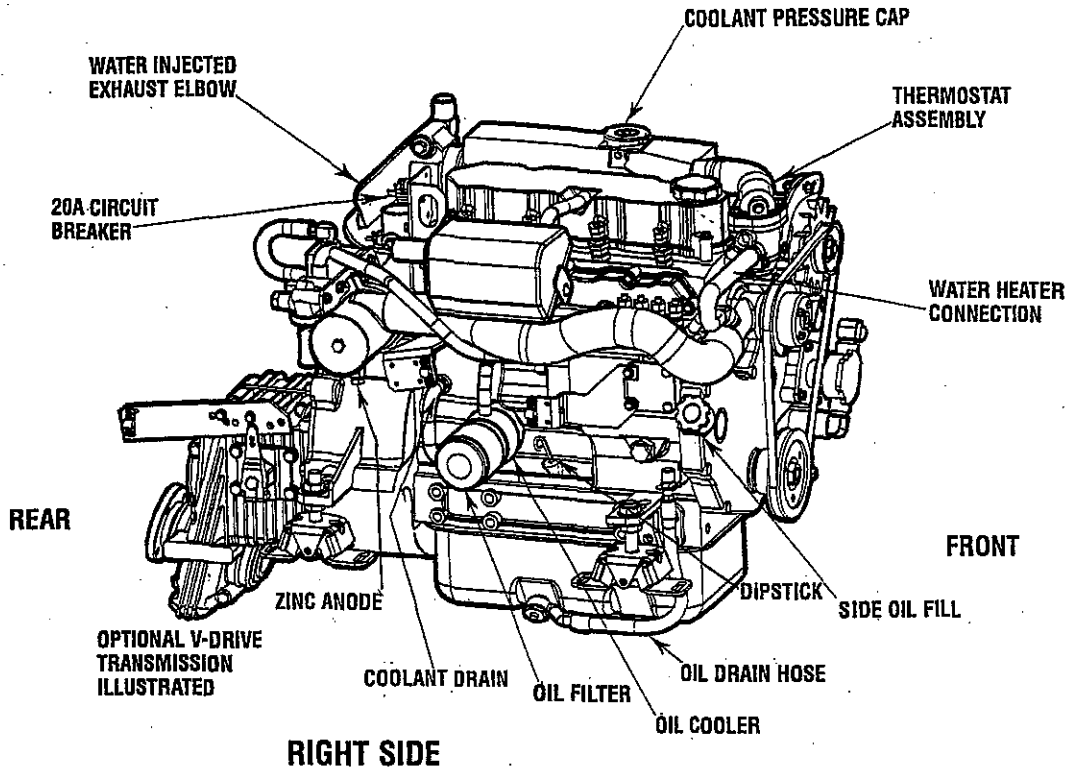



# PARTS IDENTIFICATION/GENERATORS

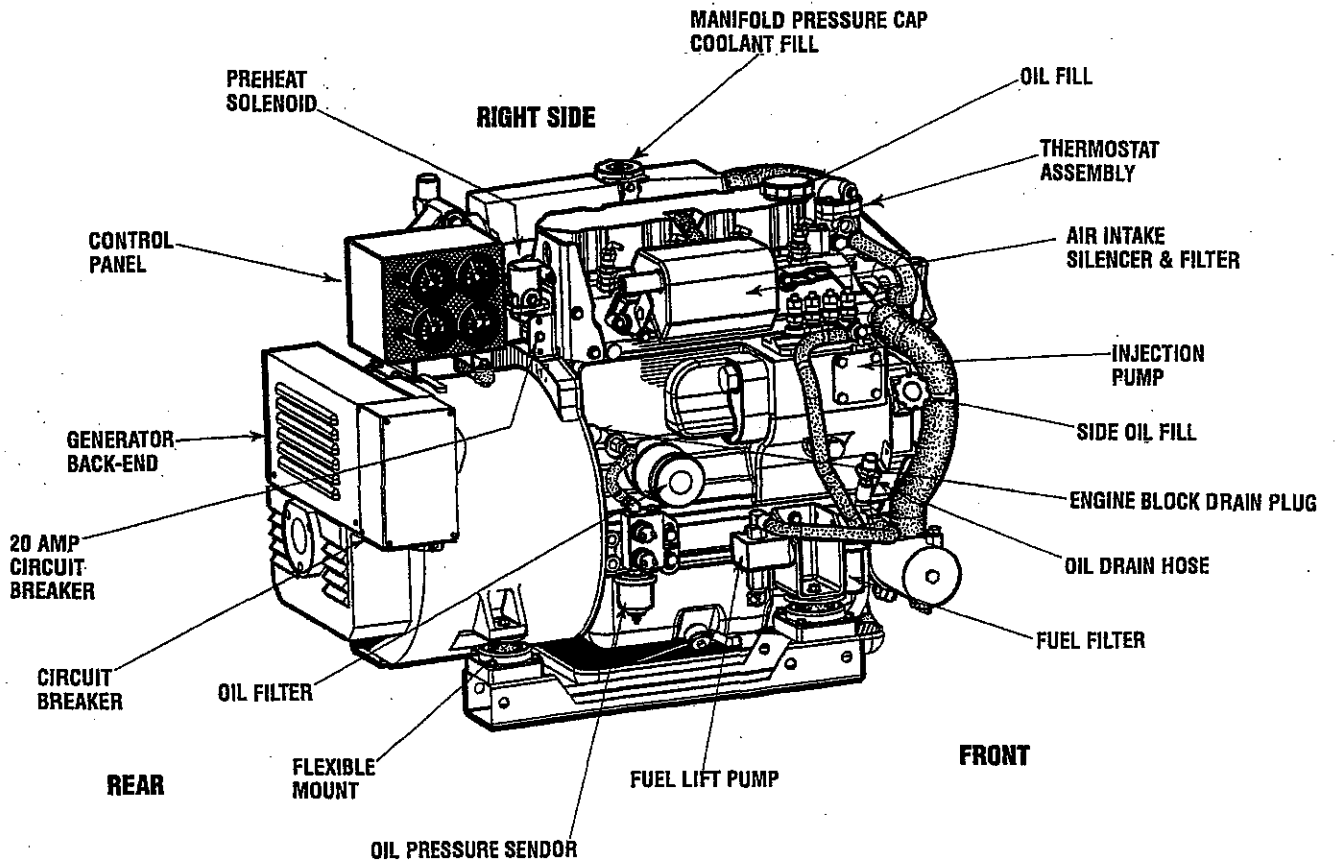
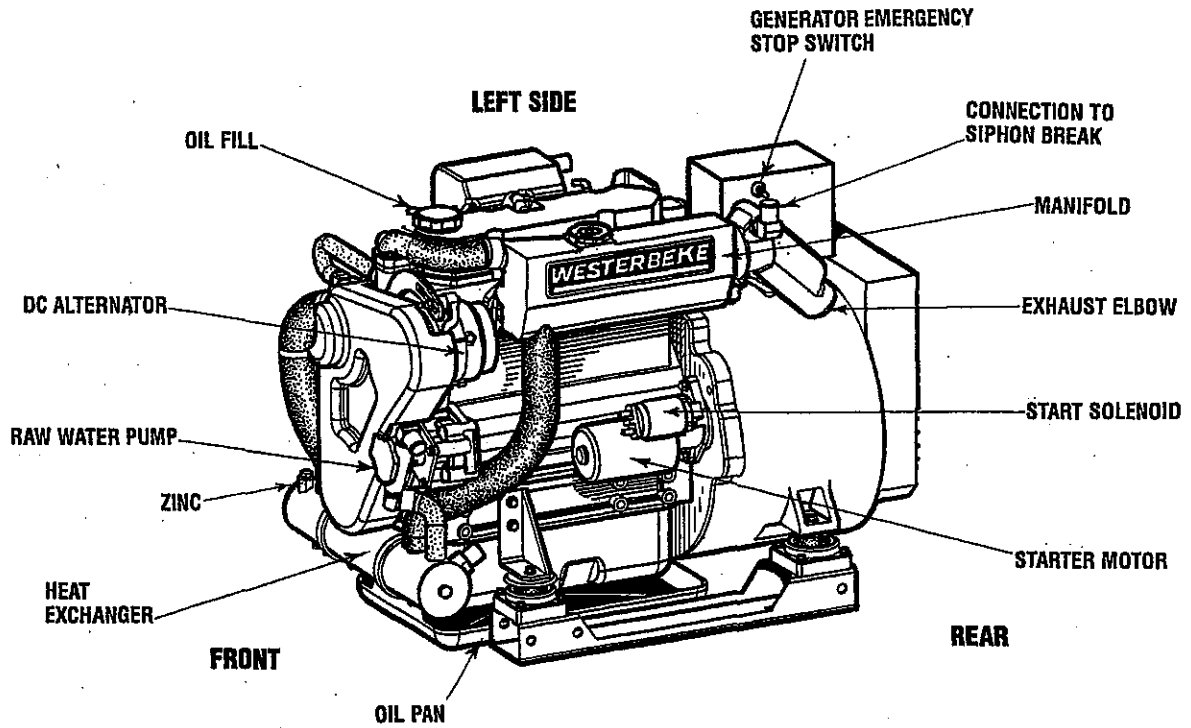

# INTRODUCTION

## PRODUCT SOFTWARE

Product software, (technical data, parts lists, manuals, brochures and catalogs), provided from sources other than WESTERBEKE are not within WESTERBEKE'S control.

**WESTERBEKE CANNOT BE RESPONSIBLE FOR THE CONTENT OF SUCH SOFTWARE, MAKES NO WARRANTIES OR REPRESENTATIONS WITH RESPECT THERETO, INCLUDING ACCURACY, TIMELINESS OR COMPLETENESS THEREOF AND WILL IN NO EVENT BE LIABLE FOR ANY TYPE OF DAMAGE OR INJURY INCURRED IN CONNECTION WITH OR ARISING OUT OF THE FURNISHING OR USE OF SUCH SOFTWARE.**

WESTERBEKE customers should keep in mind the time span between printings of WESTERBEKE product software and the unavoidable existence of earlier WESTERBEKE product software. The product software provided with WESTERBEKE products, whether from WESTERBEKE or other suppliers, must not and cannot be relied upon exclusively as the definitive authority on the respective product. It not only makes good sense but is imperative that appropriate representatives of WESTERBEKE or the supplier in question be consulted to determine the accuracy and currentness of the product software being consulted by the customer.

## NOTES, CAUTIONS AND WARNINGS

As this manual takes you through the operating procedures, maintenance schedules, and troubleshooting of your marine engine, critical information will be highlighted by NOTES, CAUTIONS, and WARNINGS. An explanation follows:

**NOTE:** *An operating procedure essential to note.*

**CAUTION:** *Procedures which, if not strictly observed, can result in the damage or destruction of your engine.*

**WARNING:** *Procedures which, if not properly followed, can result in personal injury or loss of life.*

## ORDERING PARTS

Whenever replacement parts are needed, always provide the engine model number and serial number as they appear on the silver and black nameplate located on the manifold. You must provide us with this information so we may properly identify your engine. In addition, include a complete part description and part number for each part needed (see the separately furnished Parts List). Insist upon WESTERBEKE packaged parts because *will fit* or generic parts are frequently not made to the same specifications as original equipment.

## Customer Identification Card



Customer Identification

MR. GENERATOR OWNER

MAIN STREET

HOMETOWN, USA

Model 11.5 EDT

Ser. #U0000-E811

Expires: 8/5/2013

The WESTERBEKE engine serial number was an alphanumeric number that can assist one in determining the date of manufacture. A manufacturing date code is placed at the end of the engine serial number. It consisted of a character followed by three numbers. Today it consists of two characters. Previous date code. The character indicated the decade E=2000s. The first number represented the year in the decade, and the second and third, the month of that year. Beginning in May 2008, the two characters HE. H represented 2008 and the E the month of May and so on HF 2008 July, HG 2008 July.

## SERIAL NUMBER LOCATION

The engine's serial number can be found stamped into the engine block just above the injection pump. An identification plate on the engine manifold also displays the engine model and serial number.

The generator serial number is stamped on the left side of the generator housing and on the flat surface above the rotary carrier bearings.

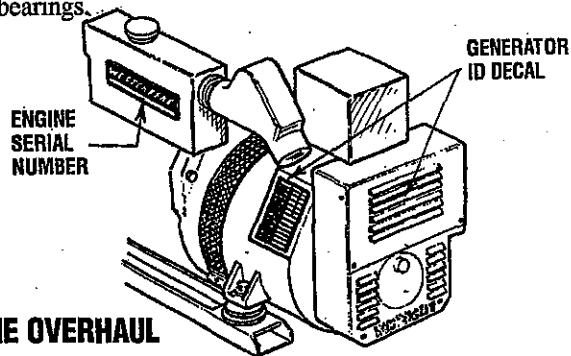

## ENGINE OVERHAUL

The following sections contain detailed information relating to the proper operation characteristics of the major components and systems of the engine. Included are disassembly, inspection and reassembly instructions for the guidance of suitable equipped and staffed marine engine service and rebuilding facilities. The necessary procedures should be taken only by such facilities.

Additional detailed information and specifications are provided in other sections of this manual, covering the generator, alternator, starter motor, engine adjustments, cooling pumps, etc.

# ENGINE TROUBLESHOOTING

The following troubleshooting chart describes certain problems relating to engine service, the probable causes of these problems, and the recommendations to overcome these problems. This chart may be of assistance in determining the need for an engine overhaul.

**NOTE:** The engine's electrical system is protected by a 20-ampere manual reset circuit breaker. The preheat solenoid is mounted on the same bracket.

PROBLEM	PROBABLE CAUSE	VERIFICATION/REMEDY
<b>HARD STARTING</b>	<b>LOW CRANKING SPEED</b> 1. Engine oil viscosity too high. 2. Run-down battery. 3. Worn battery. 4. Battery terminals loosely connected. 5. Defective starter. 6. Defective main drive section.	1. Replace engine oil with less viscous oil. 2. Recharge battery. 3. Replace battery. 4. Clean terminals and correct cables. 5. Repair or replace starter. 6. Check clutch for disengagement.
	<b>DEFECTIVE INJECTION SYSTEM</b> 1. Air trapped in fuel passage. 2. Clogged fuel filter. 3. Low injection pressure. 4. Inadequate spray. 5. Injection pump delivering insufficient fuel. 6. Injection too early.	1. Bleed air from fuel system. 2. Clean or replace filter. 3. Adjust injection pressure. 4. Clean or replace nozzle. 5. Repair or replace injection pump. 6. Adjust injection timing.
	<b>MAIN ENGINE TROUBLES</b> 1. Low compression. a. Incorrect valve clearance. b. Inadequate contact of valve seat. c. Valve stem seized. d. Broken valve spring. e. Compression leaks through cylinder head gasket. f. Piston ring seized. g. Worn piston ring and cylinder. 2. Burnt glow plug. 3. Faulty glow plug operation. 4. Incorrect governor lever position. 5. Governor spring out of POSITION	a. Adjust valve clearance. b. Lap valve. c. Replace valve and valve guide. d. Replace valve spring. e. Replace gasket. f. Replace piston and piston ring. g. Overhaul engine. 2. Replace glow plug. 3. Correct lead wire connection. 4. Set lever to starting position. 5. Correct spring
<b>LOW OUTPUT</b>	<b>LOW COMPRESSION</b>	See <b>HARD STARTING</b>
	<b>INJECTION SYSTEM OUT OF ADJUSTMENT</b> 1. Incorrect injection timing. 2. Insufficient injection. 3. Low injection pressure.	1. Adjust injection timing. 2. Repair or replace injection pump. 3. Check injection nozzle and adjust pressure.
	<b>INSUFFICIENT FUEL</b> 1. Air trapped in fuel system. 2. Clogged filter. 3. Contaminated fuel tank.	1. Check and retighten connector. 2. Clean or replace filter. 3. Clean tank.
	<b>INSUFFICIENT INTAKE AIR</b> 1. Clogged air cleaner.	1. Clean or replace air cleaner.

(continued)

# ENGINE TROUBLESHOOTING

PROBLEM	PROBABLE CAUSE	VERIFICATION/REMEDY
<b>LOW OUTPUT</b> <i>(cont.)</i>	<b>OVERHEATING</b> 1. Low coolant level. 2. Loose V-belt. 3. Incorrect injection timing. 4. Low engine oil level.	1. Add coolant. 2. Adjust or replace V-belt. 3. Adjust injection timing. 6. Add engine oil.
<b>EXCESSIVE OIL CONSUMPTION</b>	<b>OIL LEAKAGE</b> 1. Defective oil seals. 2. Broken gear case gasket. 3. Loose gear case attaching bolts. 4. Loose drain plug. 5. Loose oil pipe connector. 6. Broken rocker cover gasket. 7. Loose rocker cover attaching bolts.	1. Replace oil seals. 2. Replace gasket. 3. Retighten bolts. 4. Retighten plug. 5. Retighten oil connections. 6. Replace gasket. 7. Retighten attaching bolts.
	<b>OIL LEVEL RISING</b> 1. Worn piston ring. 2. Worn piston or cylinder. 3. Incorrectly positioned piston ring gaps. 4. Displaced or twisted connecting rod.	1. Replace ring. 2. Replace piston and rebore cylinder. 3. Correct ring gap positions. 4. Replace connecting rod.
	<b>OIL LEVEL FALLING</b> 1. Defective stem seal. 2. Worn valve and valve guide.	1. Replace stem seal. 4. Replace a valve and valve guide.
<b>EXCESSIVE FUEL CONSUMPTION</b>	<b>ENGINE BODY TROUBLES</b> 1. Noisy knocking. 2. Smoky exhaust. 3. Moving parts nearly seized or excessively worn. 4. Poor compression. 5. Improper valve timing. 6. Improper valve clearance.	1. See <i>KNOCKING</i> . 2. See <i>SMOKY EXHAUST</i> . 3. Repair or replace. 4. See <i>LOW COMPRESSION; HARD STARTING</i> . 5. Adjust. 6. Adjust.
	<b>INSUFFICIENT INTAKE AIR</b> 1. Air intake obstructed.	1. Remove obstruction.
	<b>NOZZLE TROUBLES</b> 1. Seized nozzle. 2. Worn nozzle.	1. Replace. 2. Replace.
	<b>IMPROPER FUEL</b>	Replace with proper fuel.
	<b>FUEL LEAKS</b>	Find fuel leaks.
<b>SMOKY EXHAUST</b>	<b>WHITISH OR PURPLISH</b> 1. Excessive engine oil. 2. Excessive rise of oil into combustion chamber. a. Poor piston contact. b. Seized piston ring. c. Excessive piston-to-cylinder clearance.	1. Correct oil level.  a. Check. b. Replace or clean. c. Replace or correct.

*(continued)*

# ENGINE TROUBLESHOOTING

PROBLEM	PROBABLE CAUSE	VERIFICATION/REMEDY
<b>SMOKY EXHAUST (cont.)</b>	<b>WHITISH OR PURPLISH (cont.)</b> d. Worn valve stem and valve guide. e. Low engine oil viscosity. f. Excessive oil pressure. 3. Injection timing is too late. 4. Insufficient compression.	d. Replace. e. Replace. f. Correct. 3. Adjust. 4. See <i>LOW COMPRESSION; HARD STARTING</i> .
	<b>BLACKISH OR DARK GRAYISH</b> 1. Engine body troubles. a. Poor compression. b. Improper valve clearance. 2. Insufficient intake air (air cleaner clogged). 3. Improper fuel.	a. See <i>LOW COMPRESSION; HARD STARTING</i> . b. Adjust. 2. Clean air cleaner. 3. Replace with proper fuel.
<b>ABNORMAL SOUND OR NOISE</b>	<b>CRANKSHAFT AND MAIN BEARING</b> 1. Badly worn bearing. 2. Badly worn crankshaft. 3. Melted bearing.	1. Replace bearing and grind crankshaft. 2. Grind crankshaft. 3. Replace bearing and check lubrication system.
	<b>CONNECTING ROD AND CONNECTING ROD BEARING</b> 1. Worn connecting rod big end bearing. 2. Worn crankpin. 3. Bent connecting rod.	1. Replace bearing. 2. Grind crankshaft. 3. Correct bend or replace.
	<b>PISTON, PISTON PIN, AND PISTON RING</b> 1. Worn cylinder. 2. Worn piston pin. 3. Piston seized. 4. Piston seized and ring worn or damaged.	1. Rebore cylinder to oversize and replace piston. 2. Replace piston. 3. Replace piston and rebore cylinder. 4. Replace piston and rings.
	<b>VALVE MECHANISM</b> 1. Worn camshaft. 2. Excessive valve clearance. 3. Worn timing gear. 4. Worn fan pulley bearing.	1. Replace. 2. Adjust. 3. Replace. 4. Replace.
<b>ROUGH OPERATION</b>	<b>INJECTION PUMP SYSTEM</b> 1. Uneven injection. 2. Control rack malfunctioning. 3. Worn delivery valve. 4. Inadequate injection nozzle spray.	1. Adjust injection or replace parts. 2. Disassemble, check and correct injection pump. 3. Replace. 4. Replace injection nozzle.
	<b>GOVERNING SYSTEM</b> 1. Governor lever malfunctioning. 2. Fatigued governor spring.	1. Check governor shaft and correct operation. 2. Replace.

*(continued)*

# ENGINE TROUBLESHOOTING

PROBLEM	PROBABLE CAUSE	VERIFICATION/REMEDY
<b>KNOCKING</b>	<b>ENGINE KNOCKS WITHOUT MUCH SMOKE</b> 1. Main engine troubles. a. Overheated cylinder. b. Carbon deposits in cylinder. 2. Too early injection timing. 3. Too high injection pressure. 4. Improper fuel.	a. See <i>OVERHEATING; LOW OUTPUT</i> . b. Clean. 2. Correct. 3. Correct. 4. Replace with proper fuel.
	<b>KNOCKING WITH DARK SMOKE</b> 1. Poor compression. 2. Injection pump malfunctioning. 3. Improper nozzle. a. Poor spray. b. Poor chattering. c. After-injection drip. d. Nozzle needle valve seized.	1. See <i>LOW COMPRESSION; HARD STARTING</i> . 2. Adjust/Repair  a. Clean or replace nozzle. b. Repair or replace nozzle. c. Repair or replace nozzle. d. Replace.
<b>INTERMITTENT EXHAUST SOUND</b>	1. Fuel filter clogged. 2. Fuel pipe sucks air. 3. Water mixed in fuel	1. Clean or replace. 2. Retighten pipe joints or replace pipe. 3. Replace fuel.
<b>OVERHEATING</b>	1. V-belt slacking or slippery with oil. 2. Damaged water pump. 3. Lack of coolant. 4. Low oil level or poor oil quality. 5. Knocking. 6. Moving parts seized or damaged. 7. Defective thermostat.	1. Adjust, replace or clean. 2. Replace. 3. Add. 4. Add or change. 5. See <i>KNOCKING</i> . 6. Replace. 7. Replace.
<b>LOW OIL PRESSURE</b>	1. Worn Bearings. 2. Relief valve malfunction. 3. Clogged oil cooler. 4. Diesel dilution of the oil.	1. Engine overhaul replace bearings. 2. Overhaul oil pump. 3. Repair. 4. Injection pump repair.

# TESTING FOR OVERHAUL

## HOW TO DETERMINE ENGINE OVERHAUL PERIOD

### Cause of Low Compression

Generally, the time at which an engine should be overhauled is determined by various conditions such as lowered engine power output, decreased compression pressure, and increased fuel and oil consumption. The lowered engine power output is not necessarily due to trouble with the engine itself, but is sometimes caused by injector nozzle wear or injection pump wear. The decrease in compression pressure is caused by many factors. It is, therefore, necessary to determine a cause or causes on the basis of data produced by periodic inspection and maintenance. Oil analysis on a seasonal basis is a good means of monitoring engine internal wear. When caused by worn cylinders or piston rings, the following symptoms will occur:

- 1 Low engine power output
- 2 Increased fuel consumption
- 3 Increased oil consumption
- 4 Hard engine starting
- 5 Noisy engine operation

These symptoms often appear together. Symptoms 2 and 4 can result also from excessive fuel injection, improper injection timing, and wear of the injectors. They are caused also by defective electrical devices such as the battery, alternator, starter and glow plugs. Therefore it is desirable to judge the optimum engine overhaul time by the lowered compression pressure caused by worn cylinders and pistons plus increased oil consumption. Satisfactory combustion is obtained only under sufficient compression pressure. If an engine lacks compression pressure, incomplete combustion of fuel will take place even if other parts of the engine are operating properly. To determine the period of engine overhaul, it is important to measure the engine compression pressure regularly. At the same time, the engine speed at which the measurement of compression pressure is made should be checked because the compression pressure varies with engine rpm. The engine rpm can be measured at the front end of the crankshaft.

**NOTE:** To test engine compression see the *ENGINE ADJUSTMENT* section of this manual.

### ASSEMBLY

1. Wash all parts, except for oil seals, O-rings, rubber sheets, etc., with cleaning solvent and dry them with pressure air.
2. Always use tools that are in good condition and be sure you understand how to use them before performing any job.
3. Use only good quality lubricants. Be sure to apply a coat of oil, grease or sealant to parts as specified..
4. Be sure to use a torque wrench to tighten parts for which torques are specified.
5. Ant time the engine is assembled, new gaskets and O-rings must be installed.

## OVERHAUL CONDITIONS

Compression pressure tends to increase a little in a new engine until piston rings and valve seats have been broken in. Thereafter, it decreases gradually with the progress of wear of these parts.

When decrease of compression pressure reaches the repair limit, the engine must be overhauled.

The engine requires overhaul when oil consumption is high, blowby evident, and compression values are at minimum or below. *Engine compression should be 30 kg/cm<sup>2</sup>, 427 psi at 290 rpm. The maximum difference between cylinders must not exceed 10%.*

## DISASSEMBLY

1. Before disassembly and cleaning, carefully check for defects which cannot be found after disassembly and cleaning.
2. Drain water, fuel and oil before disassembly.
3. Clean or wash the engine exterior.
4. Do not remove or disassemble the parts that require no disassembly.
5. Perform disassembly in a proper order using proper tools. Keep disassembled parts in order. Apply oil when necessary. Take special care to keep the fuel system parts from intrusion of dust and dirt.
6. Parts must be restored to their respective components from which they were removed at disassembly. This means that all parts must be set aside separately in groups, each marked for its component, so that the same combination or set can be reproduced at assembly.
7. Pay attention to marks on assemblies, components and parts for their positions or directions. Put on marks, if necessary, to aid assembly..
8. Carefully check each part or component fore any sign of faulty condition during removal or cleaning. The part will tell you how it acted or what was abnormal about it more accurately during removal or cleaning.

## ALTERNATOR INSPECTION

When rebuilding the engine, the alternator should be cleaned and inspected. The housing can be wiped off with a solvent and the alternator terminal studs should be cleaned with a wire brush. Make certain the studs are tight and clean the wiring connections that connect to the wiring harness.

Turn the rotor pulley by hand. It should turn smoothly.

Depending on when the alternator was last serviced, the brushes may need replacing. If the alternator is at all suspect, send it to a service shop for testing and overhaul.

For additional information on alternators refer to the *ALTERNATOR TROUBLESHOOTING* and *MANDO SERVICE* in this manual.

# ENGINE DISASSEMBLY

## GENERATOR

Disconnect the AC wiring and unplug the engine's DC wiring harness at the generator control panel. Remove the battery cables from the engine and tape over the terminals.

**NOTE:** Label any lines, hoses or cables as you separate them.

Separate the exhaust hose at the water injected elbow and disconnect the fuel supply and return lines.

Drain the engine oil and the coolant from the engine.

Carefully support and then unbolt the generator backend from the engine. See *SPECIAL TOOLS* in this manual.

Additional generator information will be found in the *GENERATOR* section of this manual.

## PROPULSION ENGINE

Switch off the batteries and disconnect the battery cables from the engine and tape over the terminals.

Drain or pump out all the engine oil and drain the coolant from the engine and engine hoses.

Unplug the instrument panel wiring harness. Drain the transmission fluid and the transmission oil cooler hoses, Detach the oil cooler hoses and unbolt the transmission from the engine.

**NOTE:** Label any lines, hoses or cables as you separate them.

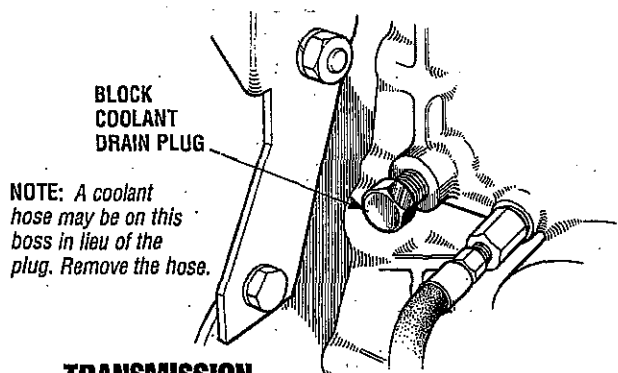

## TRANSMISSION

If the transmission is not being rebuilt it should be visually inspected. Flush out and pressure test the oil cooler and replace the coolant hoses. Inspect and lubricate the gear shift linkage and the propeller shaft coupling. Clean and repaint the transmission and change the transmission fluid.

For transmission service and maintenance refer to your transmission manual. To rebuild a transmission contact your WESTERBEKE dealer or an authorized transmission service center.

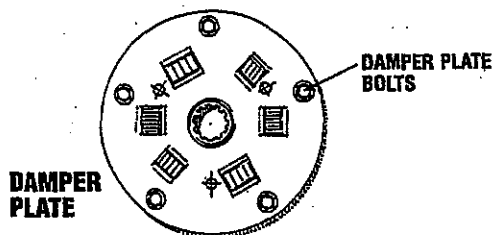

## ENGINE DISASSEMBLY

Take the following precautions:

- Clean the exterior of the engine of any deposits of dirt and oil.
- Be careful not to damage the disassembled parts.
- Arrange parts in the order of disassembly. Mark or label parts as needed to insure proper mating and reassembly. Keep parts clean.
- Mount the engine on a suitable engine stand for disassembly.

With the transmission separated from the engine, begin the following step by step procedure to disassemble the engine.

1. Remove the transmission damper plate from the engine flywheel.
2. Remove the engine oil cooler and oil hoses. Note oil hose connections from the oil cooler to the engine.
3. Remove the engine heat exchanger. If possible, leave one end of each hose connected to the part being removed.
4. Remove the bell housing and the circuit breaker/preheat solenoid mounting bracket.
5. Remove the engine back plate.
6. Remove the start motor, drive belt and the alternator. Label the wires and cables.
7. Remove the engine mounted raw water pump, complete with its adapter mounting plate. See *RAW WATER PUMP* for parts breakdown.
8. With the hoses disconnected, remove the thermostat housing and housing gasket, leaving the temperature sender in place.
9. Remove the coolant circulating pump. Refer to *COOLANT CIRCULATING PUMP ASSEMBLY*.
10. Remove the air intake silencer and the intake manifold.
11. Remove the oil filter and the mounting bracket from the engine block.
12. Unbolt the elbows and remove the exhaust manifold in its entirety.
13. Remove the fuel injection pump. Disconnect the fuel injection pipes and fuel leak-off pipe from the fuel injection pump and nozzles.

**NOTE:** Put plugs or caps on the openings of the injection pump and nozzle connectors. Golf tees work well as plugs.

14. Remove the fuel injection nozzle. Loosen the fuel injection nozzles with a wrench. Remove the nozzles and gaskets from the cylinder head.

**NOTE:** Remove the gaskets from the cylinder head with a gasket scraper. Discard the gaskets.



# ENGINE DISASSEMBLY

## 15. Remove governor assembly.

- Remove the tie rod cover.
- Remove the spring from the tie rod with pliers to disconnect the tie rod from the fuel injection pump.
- Remove the governor assembly.

## 16. Remove governor weight.

- Remove the sliding sleeve.
- Remove the sliding sleeve shaft and governor weights.

## 17. Fuel injection pump removal.

- Remove the tie rod cover.
- Remove the spring from the tie rod with pliers to disconnect the tie rod from the fuel injection pump.

## 18. Remove the fuel injection pump.

**NOTE:** Keep a record of the thickness of the shims for installation.

## 19. Remove the pressure relief valve from the cylinder block.

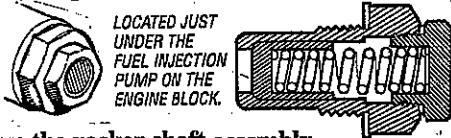

## 20. Remove the rocker shaft assembly.

- Remove the bolts that hold the rocker stays in position and remove the rocker shaft assembly.
- Remove the valve caps.

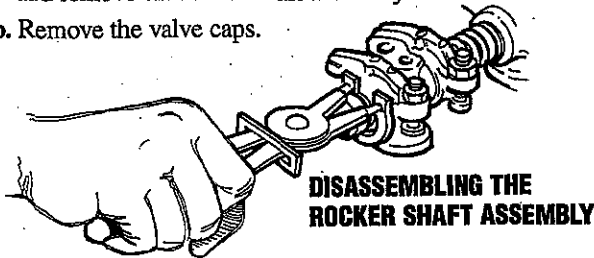

## 21. Disassemble the rocker shaft assembly. Put identification on each rocker arm as to its location on the rocker shaft.

## 22. Remove the cylinder head bolt. Loosen the cylinder head bolts in two or three steps in the sequence shown.

**NOTE:** If any parts on the cylinder head are faulty, check the cylinder head bolts for tightness with a torque wrench before loosening them.

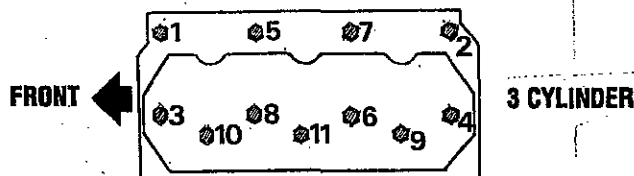
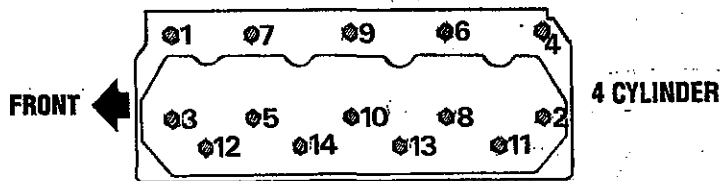

**CYLINDER HEAD BOLT LOOSENING SEQUENCE**

## 23. Remove the cylinder head assembly. Lift the cylinder head straight up with a hoist.

**NOTE:** If the gasket is seized and the cylinder head cannot be separated from the cylinder block, tap around the thick side portion of the cylinder head with a plastic hammer.

### ORDER OF DISASSEMBLY

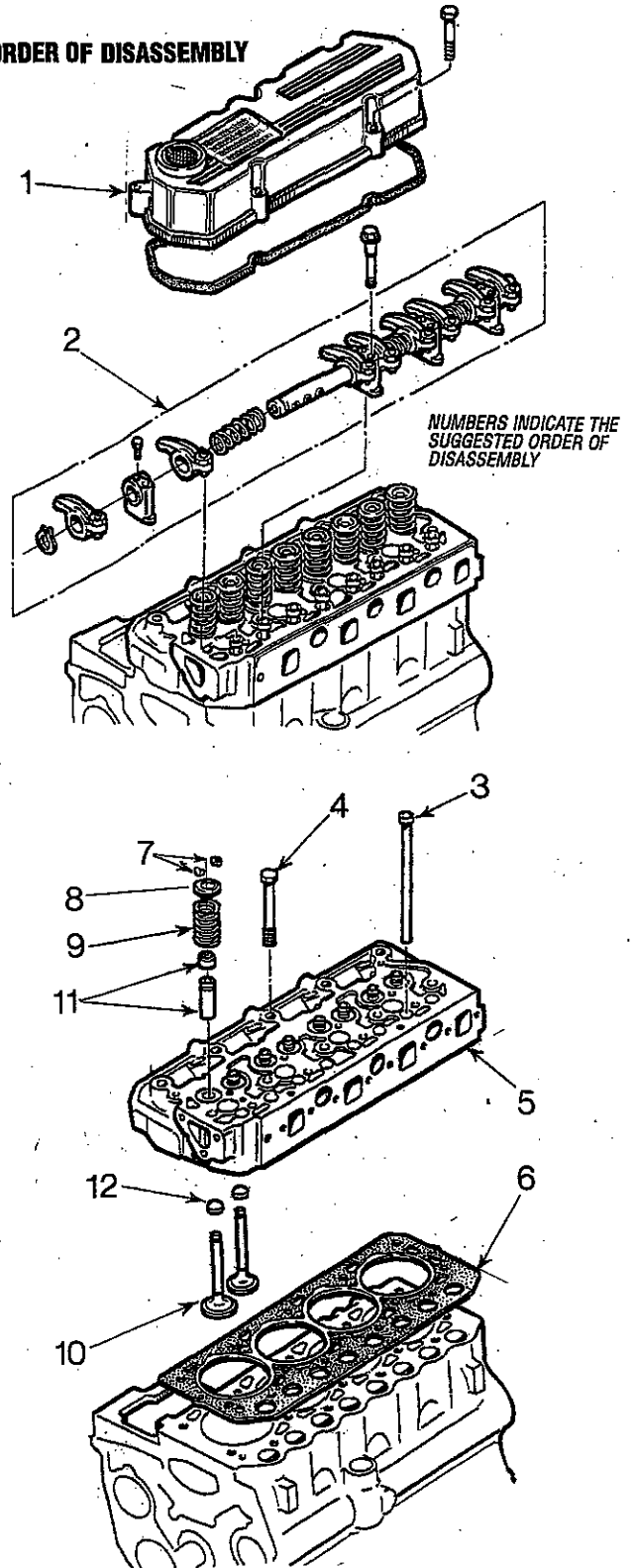

# ENGINE DISASSEMBLY

## VALVE SPRING REMOVAL

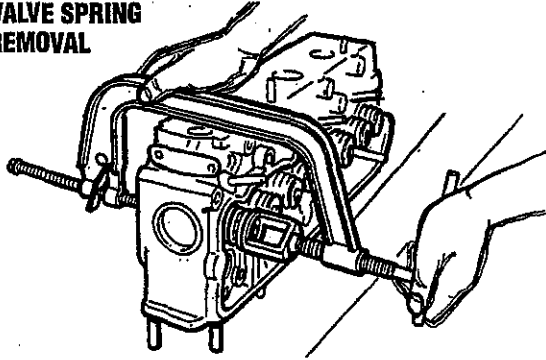

### 24. Remove the valve and valve spring.

- Compress the valve spring with a valve lifter and remove the valve lock.
- Remove the retainer, spring and valve.

**NOTE:** The valves, retainers, springs and valve locks must be set aside separately in groups, each tagged for cylinder number, for correct installation.

### 25. Remove the valve stem seals with pliers.

**NOTE:** Do not reuse the valve stem seals.

### 26. Remove the flywheel.

- Have someone hold the crankshaft pulley with a wrench to prevent the flywheel from rotating.
- Remove one of the bolts that hold the flywheel in position.
- Install a safety bar (M12 x 1.25) into the threaded hole in the flywheel from which the bolt was removed. Remove the remaining bolts.
- Hold the flywheel by hand and withdraw it from the crankshaft. Joggling the flywheel back and forth will facilitate removal.

## ORDER OF DISASSEMBLY

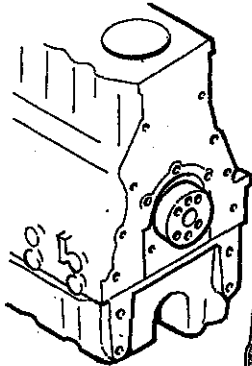

NUMBERS INDICATE THE SUGGESTED ORDER OF DISASSEMBLY

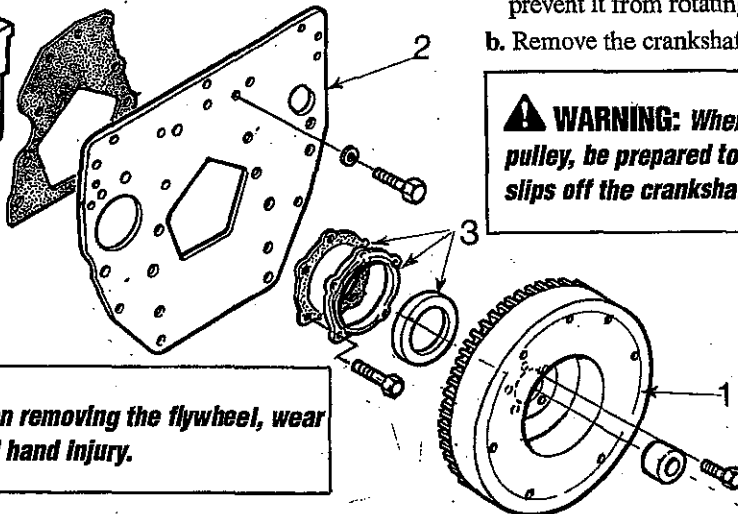

**WARNING:** When removing the flywheel, wear heavy gloves to avoid hand injury.

27. Remove the rear plate. The rear plate is doweled in position. Pull the plate as straight as possible when removing it.

28. Remove the oil seal case. Remove the bolts that hold the oil seal case in position. Remove the case from the cylinder block with a screwdriver.

**CAUTION:** Do not cause damage to the oil seal.

29. Remove the tappet. Remove the tappets from the cylinder block with a valve push rod.

**NOTE:** The tappets will fall into the oil pan if the camshaft is removed before the tappets are removed.

## REMOVING THE CRANKSHAFT PULLEY

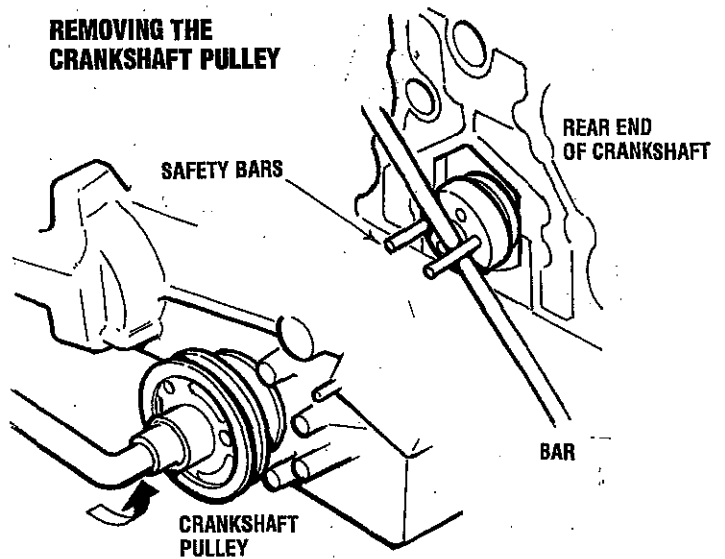

### 30. Remove the crankshaft pulley.

- Install two safety bars (M12 x 1.25) into the threaded holes in the rear end of the crankshaft. Put a bar between the safety bars to hold the crankshaft to prevent it from rotating.
- Remove the crankshaft pulley.

**WARNING:** When removing the crankshaft pulley, be prepared to stop the job in case the bar slips off the crankshaft to prevent injury.

# ENGINE DISASSEMBLY

## TIMING GEARS

### ORDER OF DISASSEMBLY

NUMBERS INDICATE THE SUGGESTED ORDER OF DISASSEMBLY

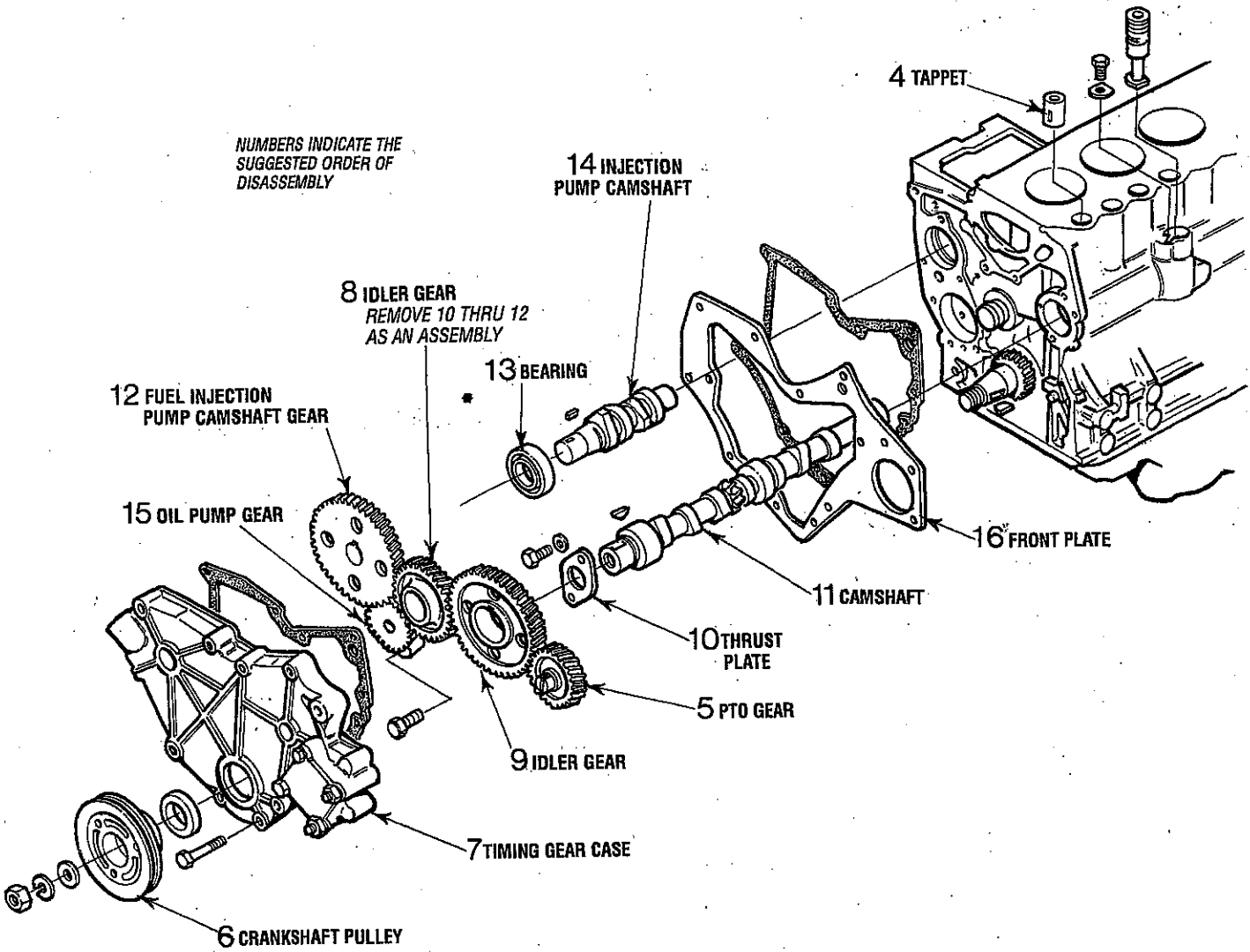

# ENGINE DISASSEMBLY

31. Remove the timing gear case. Remove the bolts that hold the timing gear case in position and remove the case.

**WARNING:** The front plate is bolted inside the timing gear case. Do not attempt to remove this plate along with the timing gear case by tapping.

32. Timing gear backlash measurement. Measure the backlash of each gear and keep a record for correct measurement. Replace the gears if the backlash exceeds the limit.

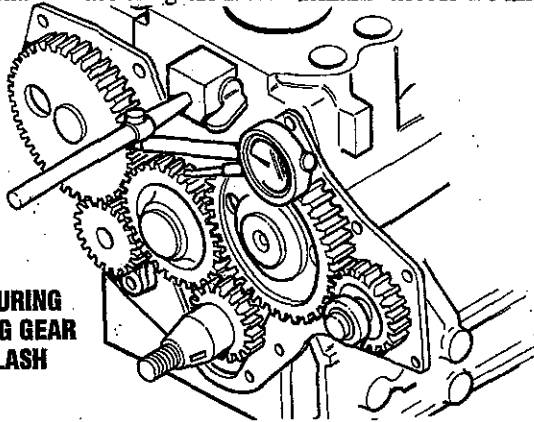

MEASURING TIMING GEAR BACKLASH

TIMING GEAR BACKLASH	STANDARD	LIMIT
CRANKSHAFT GEAR AND IDLER GEAR - IDLER GEAR AND CAMSHAFT GEAR - IDLER GEAR AND FUEL INJECTION PUMP CAMSHAFT GEAR	0.0016 - 0.0047 in (0.04 - 0.12mm)	0.0118 in (0.30mm)
CAMSHAFT GEAR/P.T.O. GEAR	0.0031 - 0.0075 in (0.08 - 0.19mm)	0.0118 in (0.30mm)
FUEL INJECTION PUMP CAMSHAFT GEAR AND OIL PUMP GEAR	0.0028 - 0.0079 in (0.07 - 0.20mm)	0.0118 in (0.30mm)

33. Remove the idler gear. To remove the idler gear, rotate the gear in a direction of the helix of the teeth to pull it out of mesh.

34. Remove the camshaft.

- Remove the bolts that hold the thrust plate.
- Pull the camshaft out of the cylinder block.

**CAUTION:** Do not cause damage to the lobes or bearing journals when removing the camshaft

35. Remove the fuel injection pump camshaft.

- Remove the stopper bolt.
- Tap the rear end of the camshaft with a copper bar to push it out of the front side of the cylinder block.

36. Remove the gear (when required). To remove the gears from the camshaft and fuel injection pump camshaft, use an arbor press.

37. Remove the oil pump. Remove the bolts that hold the oil pump to the cylinder block and remove the pump.

38. Remove the front plate. Remove four bolts that hold the front plate in position. Tap the plate lightly with a plastic hammer to separate the gasket.

39. Remove the oil pan.

- Turn the engine upside down.
- Tap the bottom corners of the oil pan with a plastic hammer to remove the oil pan.

**CAUTION:** Do not attempt to pry off the oil pan by inserting a screwdriver or a chisel between the oil pan and the cylinder block. Damage to the oil pan can be the result.

40. Remove the oil screen. Loosen the nut that holds the oil screen in position and remove the screen.

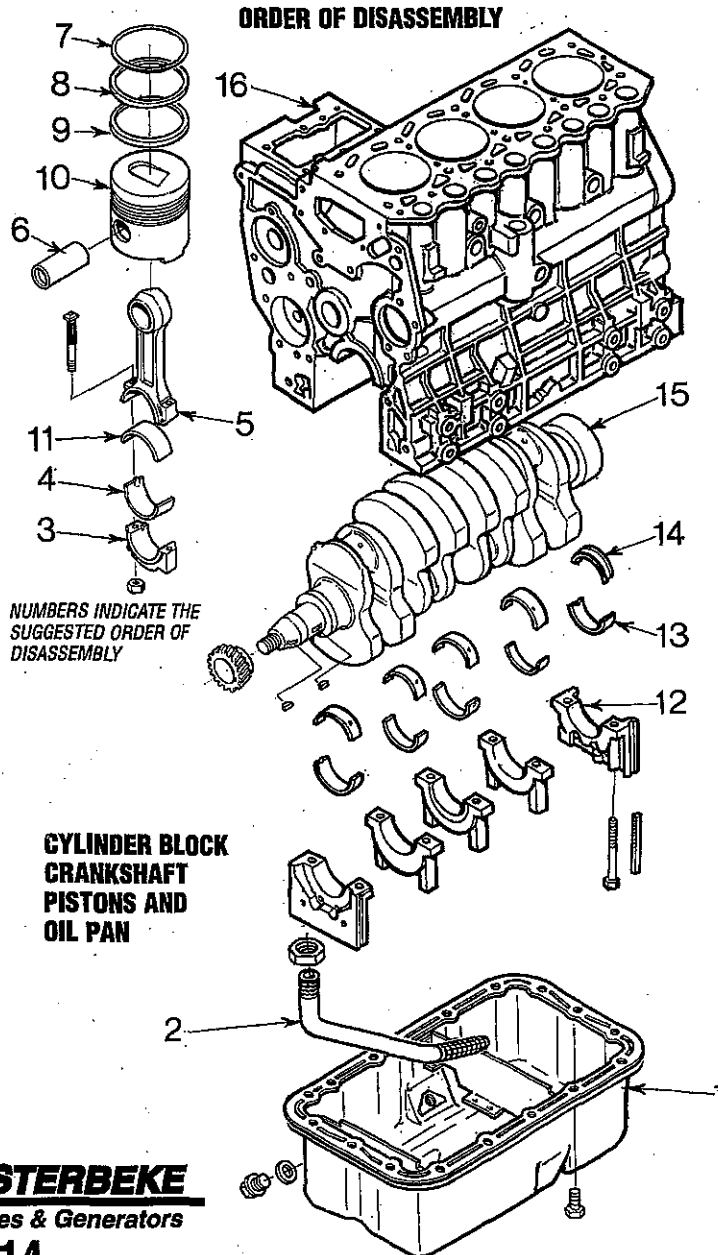

# ENGINE DISASSEMBLY

41. Thrust clearance measurement for connecting rod big end. Install the connecting rod to its crankpin and tighten the cap nuts to the specified torque. Measure the thrust clearance with a feeler gauge. If the clearance exceeds the limit, replace the connecting rod.

## THRUST CLEARANCE

STANDARD: 0.0039 - 0.0138 in (0.10 - 0.35mm)

LIMIT: 0.0197 in (0.50mm)

**MEASURING THRUST CLEARANCE FOR CONNECTING ROD BIG END**

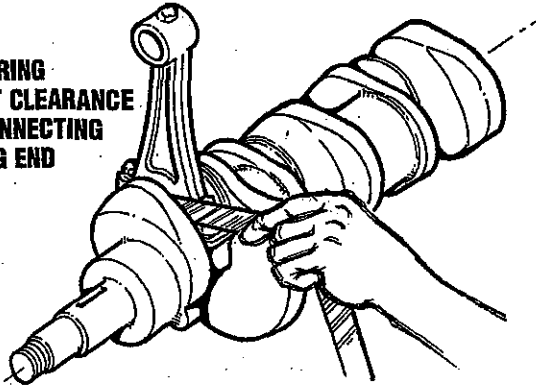

42. Remove the connecting rod cap.
- Lay the cylinder block on its side.
  - Put identification on each connecting rod and cap combination as to its location in the engine.
  - Remove the caps.
43. Remove the piston.
- Turn the crankshaft until the piston is at top center.
  - Push the piston and connecting rod away from the crankshaft with the handle of a hammer until the piston rings are above the cylinder. Remove the piston and connecting rod. Repeat steps a and b for the removal of the other pistons.

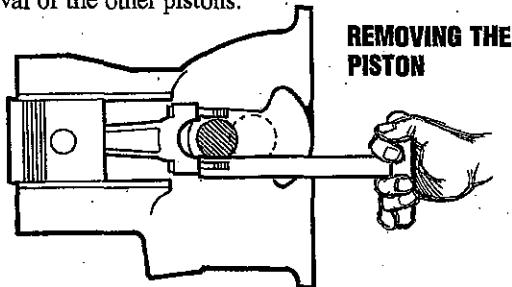

**REMOVING THE PISTON**

44. Measuring the crankshaft end play. Set a dial indicator so that it will touch the end of the crankshaft and measure the end play. If the end play exceeds the limit, replace the flanged bearing.

## CRANKSHAFT END PLAY

STANDARD: 0.00197 - 0.00689 in (0.050 - 0.175mm)

LIMIT: 0.01969 in (0.500 mm)

45. Remove the main bearing cap.
- Lay the cylinder block with its bottom (oil pan) side up.
  - Remove the bolts that hold the main bearing caps in position. Remove the caps.
  - Remove the front and rear bearing caps with a sliding hammer.

46. Remove the crankshaft.

**CAUTION:** Do not cause damage to the bearings.

**NOTE:** Put identification on each main bearing as to its location in the engine.

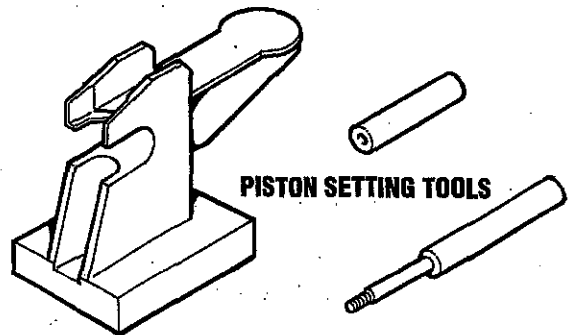

**PISTON SETTING TOOLS**

47. Separate the piston from the connecting rod.
- Use Piston Pin Setting Tool to separate the piston from the connecting rod.
  - Insert the push rod of the tool into the bore in the piston for the piston pin and, using an arbor press, remove the piston pin.
  - Also use the Piston Pin Setting Tool to install the connecting rod to the piston.

**CAUTION:** Do not attempt to remove the piston pin by tapping. Replace any piston pin which requires a greater force for removal.

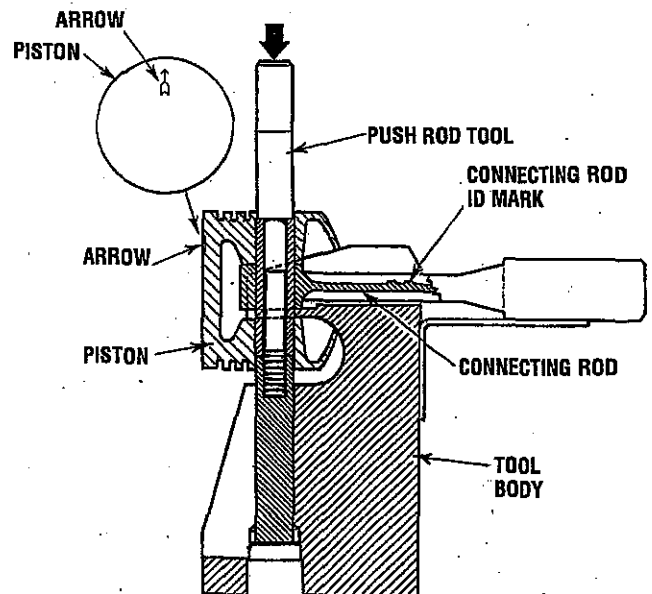

# INSPECTION

## CYLINDER HEAD AND VALVE MECHANISM

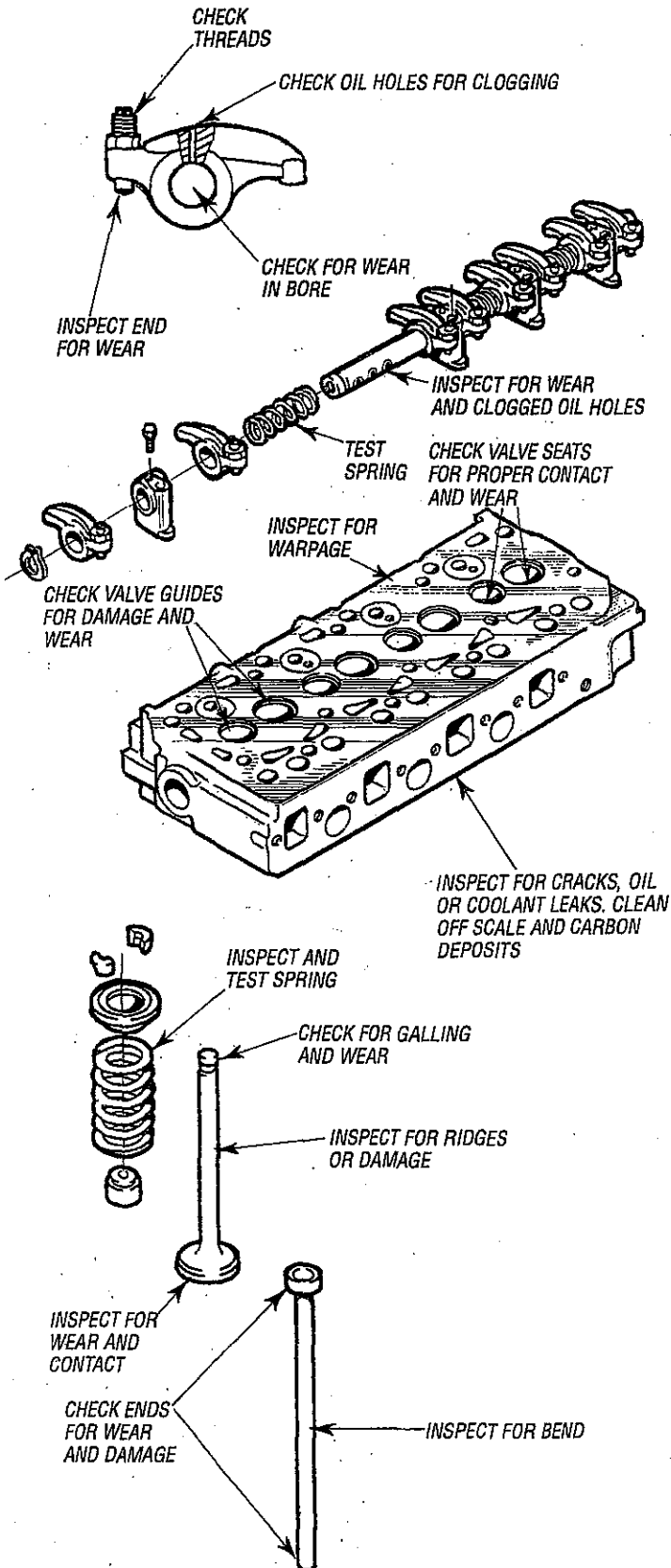

- 1. Cylinder head.** Using a heavy accurate straight edge and a feeler gauge, check the bottom face for warpage in three positions, lengthwise, two crosswise and two widthwise as shown in the illustration. If warpage exceeds the limit, reface the bottom face with a surface grinder.

**WARPAGE - CYLINDER HEAD BOTTOM FACE**

STANDARD	0.0020 in (0.05mm)	MAXIMUM
LIMIT	0.0039in ((0.10mm)	

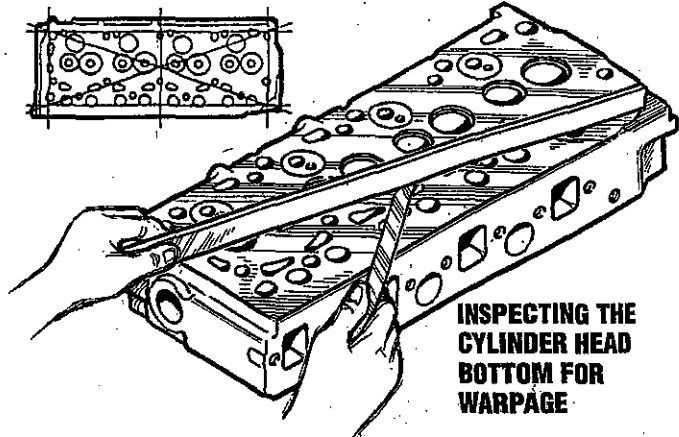

- 2. Rocker arms and rocker shaft.** Measure the bore in the rocker arm for the rocker shaft and the diameter of the rocker shaft to find the clearance between the arm and the shaft. If the clearance has reached the limit, replace the rocker arm. If it exceeds the limit, replace both arm and shaft.

**BORE IN ROCKER ARM FOR SHAFT**

STANDARD	0.74449 - 0.74527 in (18.910 - 18.930mm)
----------	--

**DIAMETER OF SHAFT FOR ARM**

STANDARD	0.74331 - 0.74401 in (18.880 - 18.898mm)
----------	--

**CLEARANCE BETWEEN ROCKER ARM AND SHAFT**

STANDARD	0.00047 - 0.00197 in (0.012 - 0.050mm)
LIMIT	0.00787 (0.200mm)

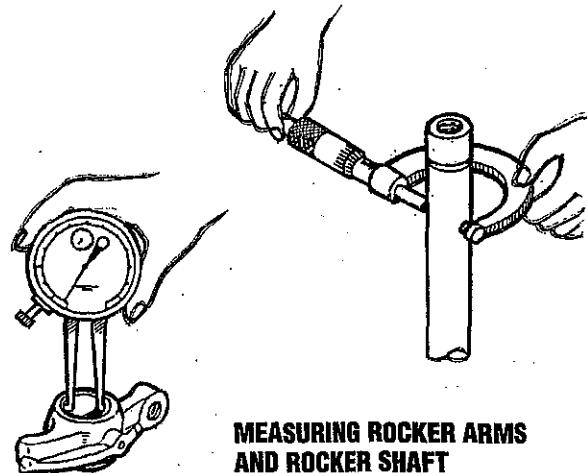

# INSPECTION

3. **Valve springs.** Check the squareness and free length. If the squareness and/or free length exceeds the limit, replace the spring.

**VALVE SPRING FREE LENGTH**  
**STANDARD** 1.85 in (47mm)  
**LIMIT** 1.81 in (46mm)

**SPRING SQUARENESS**  
**STANDARD** 1.5° MAXIMUM

**SPRING TEST FORCE - LENGTH UNDER TEST FORCE**  
 (1.54 in (39.1mm))

**STANDARD** 30.6 ± 1.5 lb-ft  
 13.9 ± 0.7 Kg -f  
**LIMIT** -15%

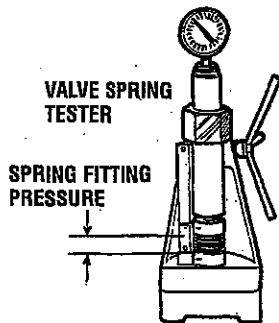
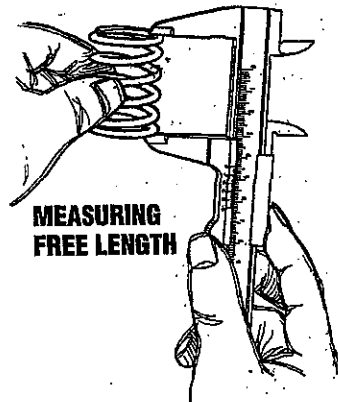
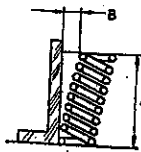
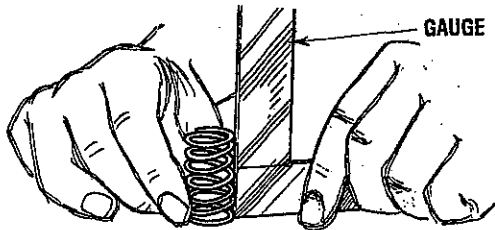

4. **Valve push rods.** Using V-blocks and a dial indicator, check for bend. If the bend exceeds the limit, replace the push rod.

**BEND (DIAL INDICATOR READING) OF VALVE PUSH ROD**  
**LIMIT** 0.012 in (0.3mm) MAXIMUM

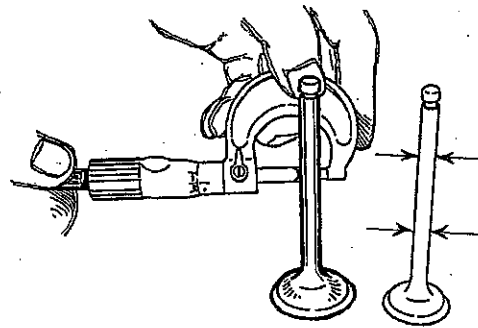
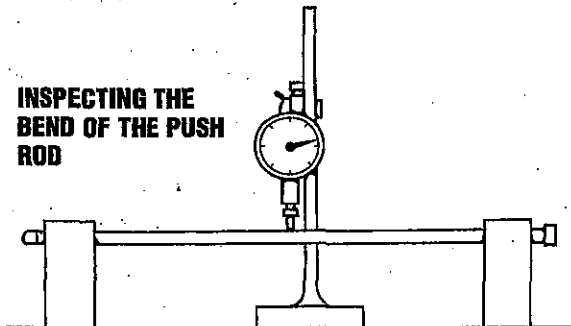

## CHECKING VALVE STEM WEAR

5. **Valves, valve guides and valve seats.**

a. Measure the diameter of the valve stem as shown in the illustration. If the stem is worn beyond the limit, or it is abnormally worn, replace the valve.

**VALVE STEM DIAMETER (NORMAL SIZE 0.260 in (6.6mm) INLET AND EXHAUST)**

<b>INLET VALVE: STANDARD</b>	0.25846 - 0.25905 in (6.565 - 6.580mm)
<b>LIMIT</b>	0.25591 in (6.500mm)
<b>EXHAUST: STANDARD</b>	0.25709 - 0.25787 in (6.530 - 6.550mm)
<b>LIMIT</b>	0.25591 in (6.500mm)

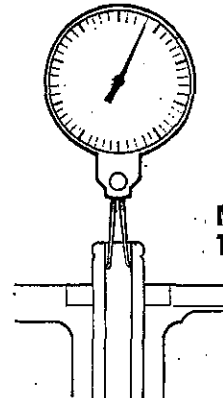

b. The valve guide wears more rapidly at its both ends than any other parts. Measure the bore in the guide for the stem at its ends with an inside micrometer caliper to find the clearance between the stem and guide. If the clearance exceeds the limit, replace the guide or valve whichever is badly worn.

**CLEARANCE BETWEEN THE VALVE STEM AND VALVE GUIDE**

<b>INLET VALVE: STANDARD</b>	0.008 - 0.0020 in (0.02 - 0.05mm)
<b>LIMIT</b>	0.0039 in (0.10mm)
<b>EXHAUST VALVE: STANDARD</b>	0.0020 - 0.00335 in (0.05 - 0.085mm)
<b>LIMIT</b>	0.0059 in (0.15mm)

# INSPECTION

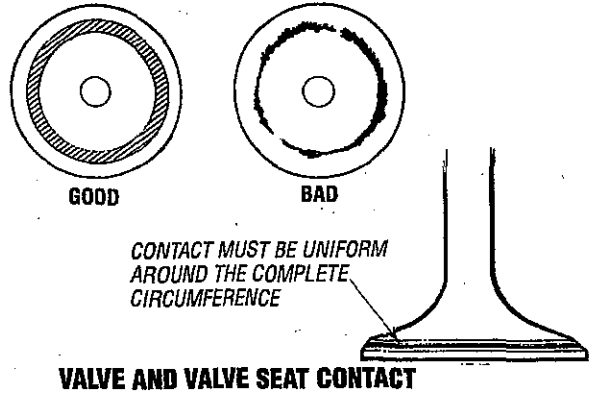
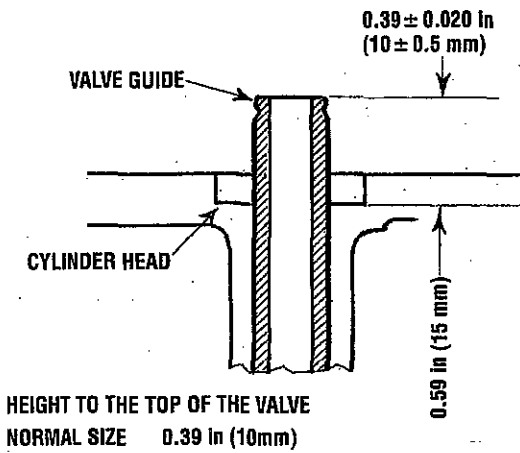

## c. Valve guide replacement.

- (1) Remove the guide from the cylinder head by pushing it with a tool and an arbor press from the bottom side of the head.
- (2) Install a new guide into the cylinder head by pushing it with an arbor press from the upper side of the head until the specified height to the top of the guide is obtained.
- (3) Insert a new valve into the guide and make sure the valve slides in the guide freely.
- (4) After the valve guide has been replaced, check the valve contact with its seat.
- (5) Put a small amount of Prussian blue or read lead on the valve face. Hold the valve with a valve lapping tool (commercially available) and press it against the seat to check its contact.

## 6. Valve refacing.

- a. Set the valve refacer at an angle of 45° and grind the valve.
- b. The valve margin must not be less than the limit. If the margin seems to be less than the limit when the valve is refaced, replace the valve.

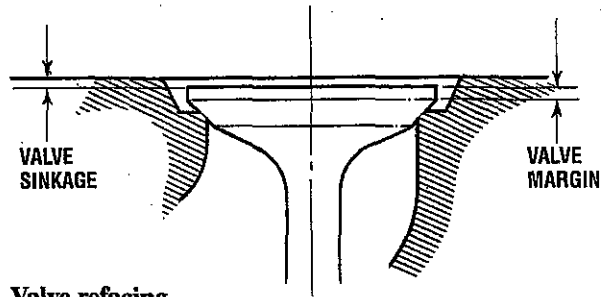

## LAPPING THE VALVE IN THE SEAT

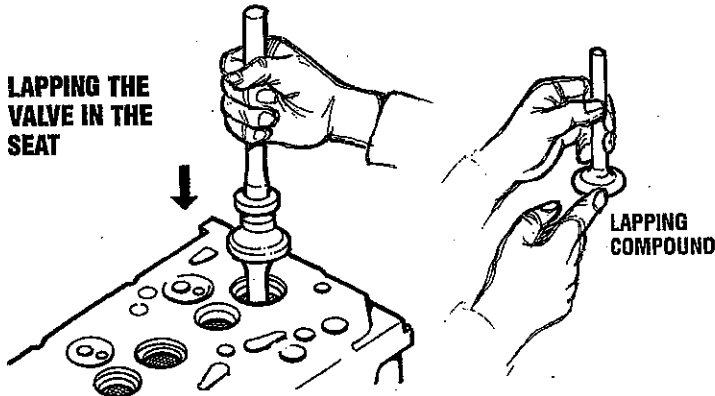

- (6) The width of contact must be uniform all the way around both seat and valve. If the contact is bad, reface the valve and seat.
- (7) If the valve margin (valve lip thickness) exceeds the limit, replace the valve.

## VALVE MARGIN (LIP) THICKNESS

STANDARD	0.039 in (1.0mm)
LIMIT	0.020 in (0.5mm)

- (8) If the valve sinkage (the dimension from the top of a closed valve to the face of cylinder head) exceeds the limit, recondition the valve seat or replace the cylinder head assembly.

## VALVE SINKAGE

STANDARD	0.020 ± 0.0098 in (0.5 ± 0.25mm)
LIMIT	0.059 in (1.5mm)

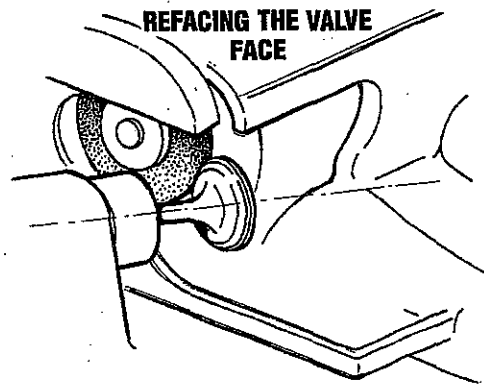

## 7. Valve seat refacing.

- a. Before refacing the valve seat, check the clearance between the valve and guide, and replace the guide if necessary.
- b. Cut the valve seat with a valve seat cutter (commercially available), or grind it with a valve seat grinder, and finish the width of valve seat and the angle of seat face to the correct values.

ANGLE OF SEAT FACE: STANDARD 45°

## WIDTH OF VALVE SEAT

STANDARD	0.051 - 0.071 in (1.3 - 1.8mm)
LIMIT	0.098 in (2.5mm)



# INSPECTION

## REFACING THE VALVE SEATS

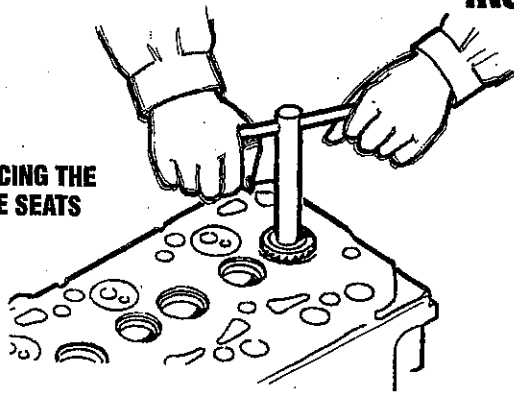

c. After refacing the valve seat, put lapping compound on the valve face and lap the valve in the valve seat.

## 8. Valve lapping. Be sure to lap the valves in the seats after refacing or replacing the valves or valve seats.

a. Put a small amount of lapping compound on the valve seat.

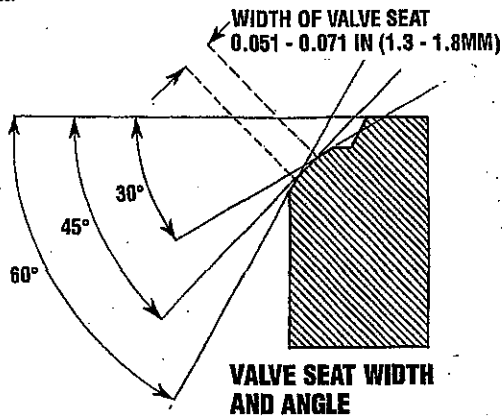

**NOTE:** Do not put lapping compound on the valve stem. Use a lapping compound of 120 to 150 mesh for initial lapping and a compound of finer than 200 mesh for finish lapping.

Mixing the compound with a small amount of engine oil will help put the compound on the valve face uniformly.

- Using a lapping tool, hold the valve against the seat and rotate it only a part of a turn, then raise the valve off its seat, rotating it to a new position. Press the valve against the seal for another part of a turn. Repeat this operation until the compound wears and loses its cutting property.
- Wash the valve and valve seat with dry cleaning solvent.
- Apply engine oil to the valve and lap it in the seat.
- Check the valve face for contact.

LAPPING VALVE IN SEAT

APPLYING LAPPING COMPOUND

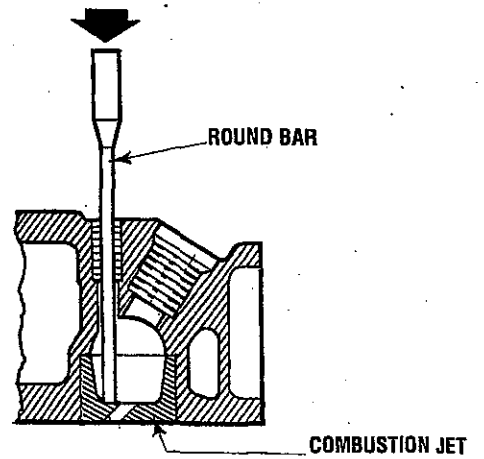
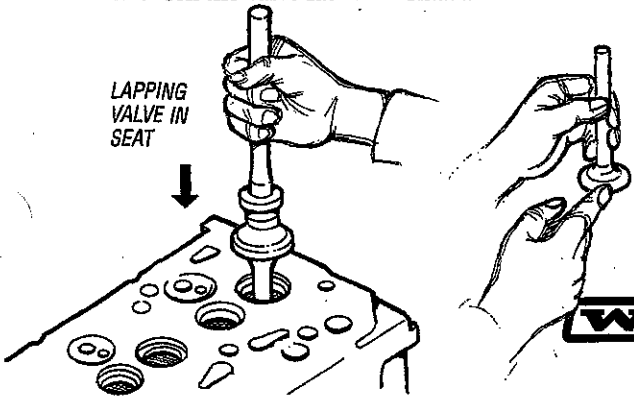

## 9. Combustion jet replacement. Replace the combustion jets only when they are cracked or defective.

a. To remove the jet, insert a 6mm (0.25in) diameter round bar through the bore in the cylinder head for the glow plug and tap around the jet.

b. To install a new jet, put the jet in position in the head with its tangential orifice in alignment with the center of the main chamber and tap it with a plastic hammer.

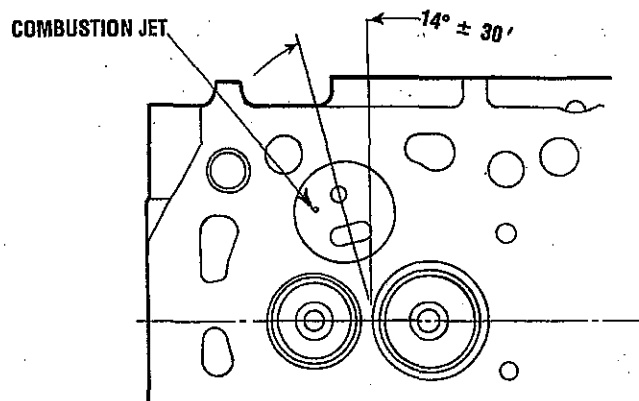

# ENGINE INSPECTION

## TIMING GEARS AND FLYWHEEL - INSPECTION POINTS

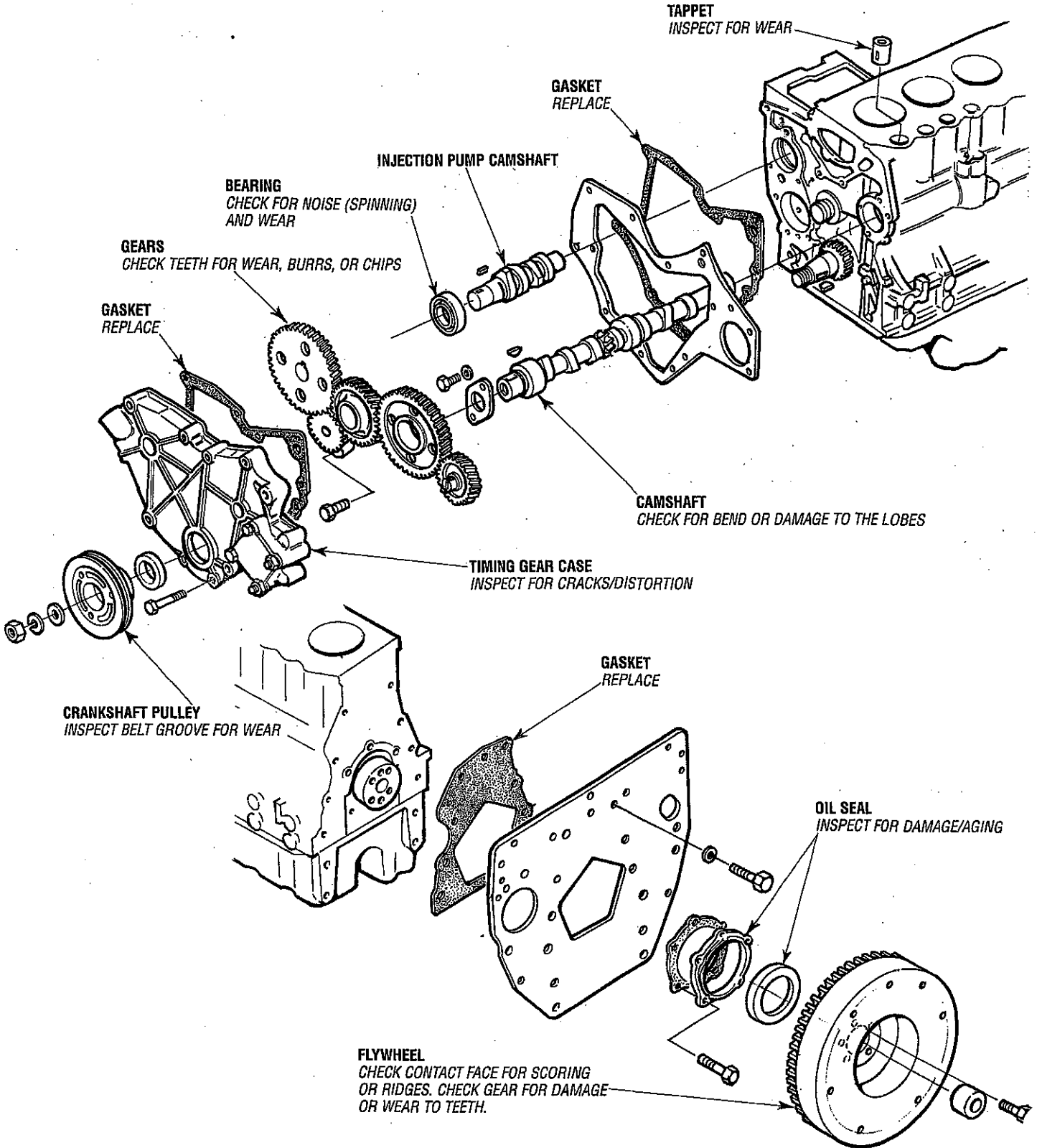

# INSPECTION

## 10. Camshaft

- a. Measure the diameter of the journal and the bore in the bushing for the shaft to find the clearance as shown in the illustration. If the clearance exceeds the limit, replace the bushing.

**CLEARANCE BETWEEN THE CAMSHAFT JOURNAL AND BUSHING**  
**STANDARD 0.0059 in (0.15mm)**

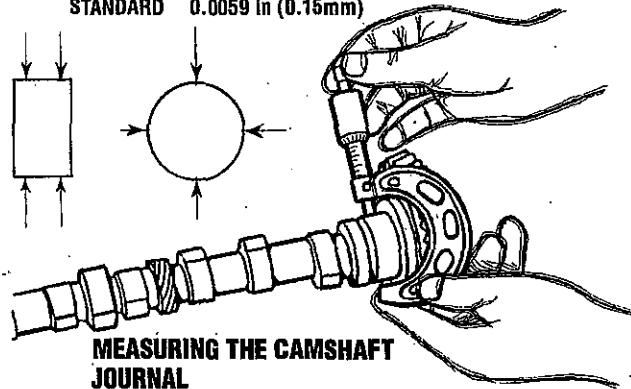

- b. Use Camshaft Bushing Installer (special tool) for camshaft bushing replacement.

- (1) Remove the oil pan. Using a "remover" end of the cylinder, push out the bushing into the cylinder block. Crush and take out the bushing from the block.

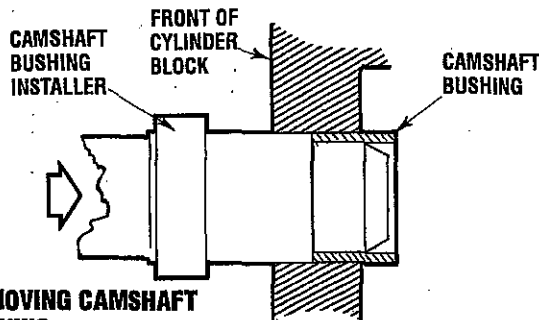

- (2) Install a new bushing in position with its oil holes in alignment with those of the oil gallery.

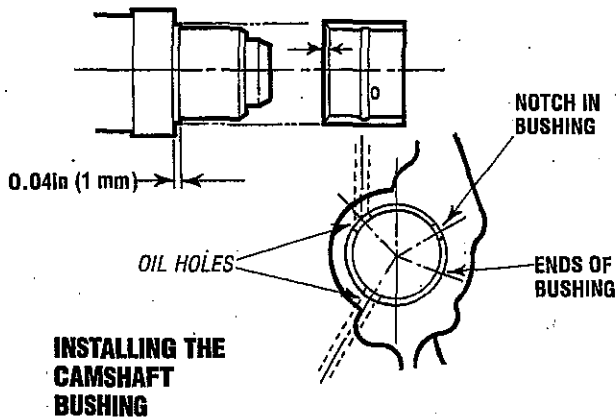

- (3) Measure the lobe height and base circle as shown in the illustration. Subtract the base circle from the lobe height to find the lobe lift. If the lobe lift exceeds the limit, replace the camshaft.

### LOBE HEIGHT OF CAMSHAFT

**STANDARD 1.4063 in (35.72mm)**  
**LIMIT 1.3669 in (34.72mm)**

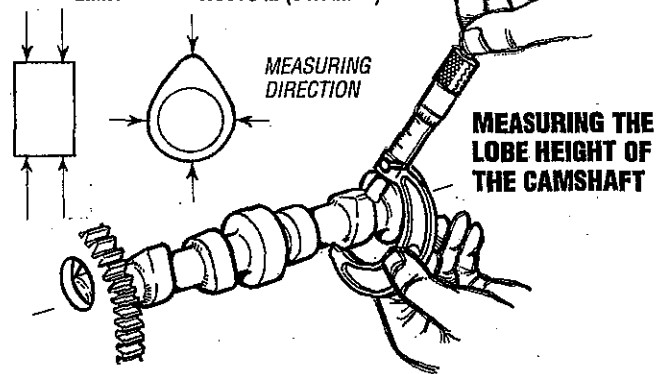

11. **Fuel injection pump camshaft.** Measure the lobe height and base circle as shown in the illustration. Subtract the base circle from the lobe height to find the lobe lift. If the lobe lift exceeds the limit, replace the camshaft.

### LOBE HEIGHT OF FUEL INJECTION PUMP CAMSHAFT

**STANDARD 1.73 in (44mm)**  
**LIMIT 1.69 in (43mm)**

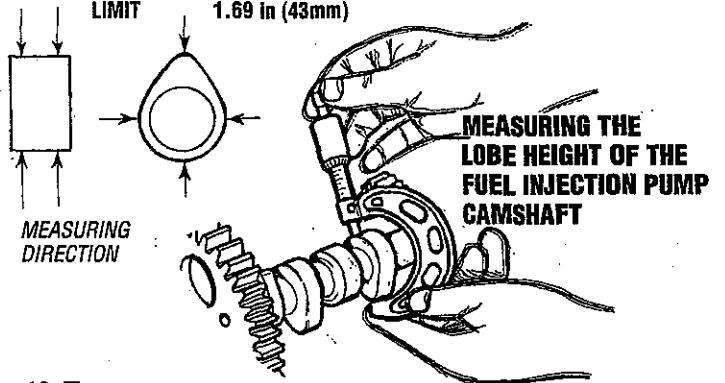

## 12. Tappets.

- a. Check the cam contact face of each tappet for abnormal wear. Replace the tappet if the face is defective.
- b. Measure the diameter of the tappet and the bore in the cylinder block for the tappet to find the clearance. If the clearance exceeds the limit, replace the tappet.

**CLEARANCE BETWEEN THE TAPPET AND THE CYLINDER BLOCK**  
**STANDARD 0.0059 in (0.15mm)**

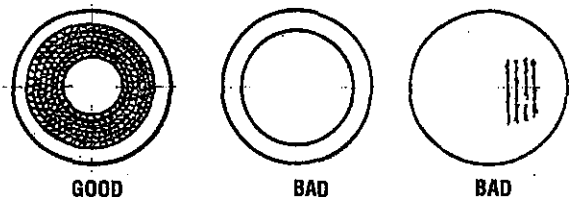

**CAM CONTACT FACE OF THE TAPPET**

# INSPECTION

## 13. Idler gear:

- a. Measure the bore in the idler gear for the shaft and the diameter of the shaft to find the clearance. If the clearance exceeds the limit, replace the gear or shaft whichever is badly worn.

**CLEARANCE BETWEEN THE IDLER GEAR AND THE SHAFT**  
**STANDARD** 0.0012 - 0.0028 in (0.03 - 0.07mm)  
**LIMIT** 0.0079 in (0.20mm)

- b. Install a new idler shaft to the cylinder block so that its dimension from the face of the block is  $1.043 \pm 0.020$  in ( $26.5 \pm 0.5$ mm).

**DIMENSION OF THE IDLER SHAFT FROM THE BLOCK FACE**

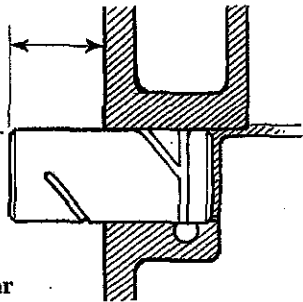

## 14. Flywheel and ring gear

- a. Put the flywheel on the surface plate. Set a dial indicator at one side of the friction (clutch contact) face and move it over to the opposite side of the face as shown in the illustration to find flatness. If flatness exceeds the limit, grind the face.

**FLATNESS OF THE FLYWHEEL**  
**STANDARD** 0.0059 in (0.15mm) MAXIMUM  
**LIMIT** 0.0197 in (0.50mm)

**MEASURING FLYWHEEL FLATNESS**

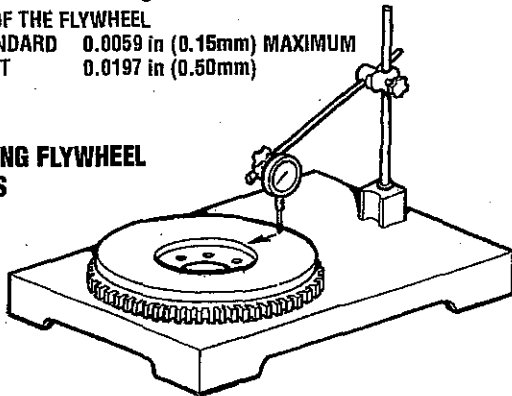

- b. Check the ring gear and replace it if its teeth are abnormally worn or chipped.

### (1) Removal

Heat the ring gear evenly with an acetylene torch. Tap the ring gear all the way around with a bar and a hammer as shown in the illustration to remove it from the flywheel.

### (2) Installation

Heat a new ring up to a temperature of 302°F (150°C) with a piston heater and install it to the flywheel with its unchamfered side foremost.

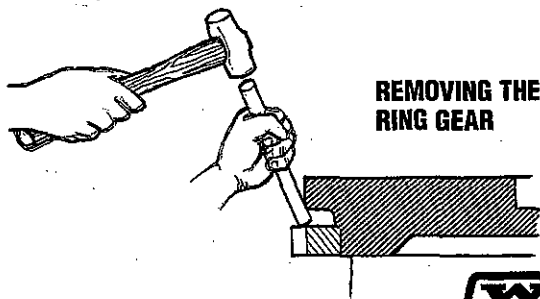

**REMOVING THE RING GEAR**

## 15. Pistons, piston rings and piston pins.

- a. Measure the diameter of the piston at its skirt in a direction transverse to the piston pin with a micrometer as shown in the illustration. If the diameter exceeds the limit, replace the piston. Select a new piston so that the difference between average weight of all pistons in one engine does not exceed the standard.

DIAMETER OF PISTON	STANDARD	LIMIT
STANDARD (NOMINAL SIZE 3.0709 in (78.00mm))	3.0681 - 3.0689 in (77.93 - 77.95mm)	3.063 in (77.80mm)
OVERSIZE 0.0098 in (0.25mm) (NOMINAL SIZE 3.0807 in 78.25mm)	3.0779 - 3.0787 in (78.18 - 78.20mm)	3.0728 in (78.05mm)
OVERSIZE 0.0197 in (0.50mm) (NOMINAL SIZE 3.0905 in 78.50mm)	3.0878 - 3.0886 in (78.43 - 78.45mm)	3.0827 in (78.30mm)

**MAXIMUM PERMISSIBLE DIFFERENCE BETWEEN AVERAGE WEIGHT OF ALL PISTONS IN ONE ENGINE, g(oz)**  
**STANDARD** 0.18 in (5mm)

**MEASURING DIRECTION**

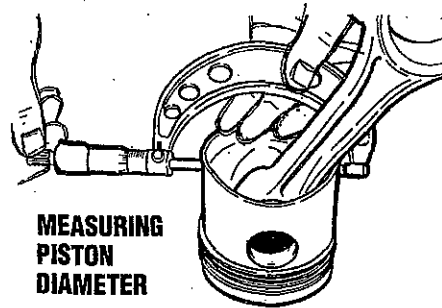

**MEASURING PISTON DIAMETER**

- b. Measure the clearance between the groove and piston with a straight edge and a feeler gauge. If the clearance exceeds the limit, replace the ring.

COMPRESSION RING CLEARANCE	STANDARD	LIMIT
NO.1 COMPRESSION RING	0.0024 - 0.0039 in (0.06 - 0.10mm)	0.0118 in (0.30mm)
NO.2 COMPRESSION RING	0.0020 - 0.0035 in (0.05 - 0.9mm)	0.0079 in (0.20mm)
OIL RING	0.0012 - 0.0028 in (0.03 - 0.07mm)	0.0079 in (0.20mm)

- c. If the clearance still exceeds the limit after new piston rings have been installed, replace the piston.

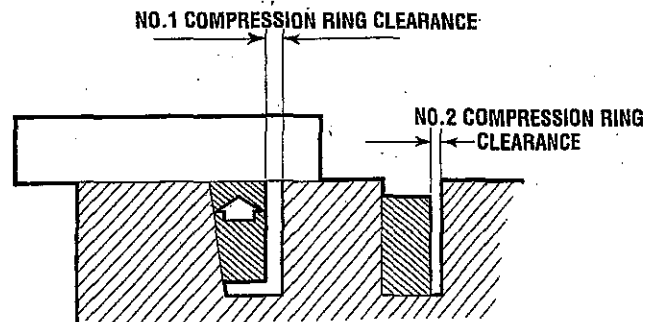

**MEASURING THE CLEARANCE BETWEEN THE PISTON RING AND GROOVE**

# ENGINE INSPECTION

## CYLINDER BLOCK, CRANKSHAFT, PISTONS AND OIL PAN - INSPECTION POINTS

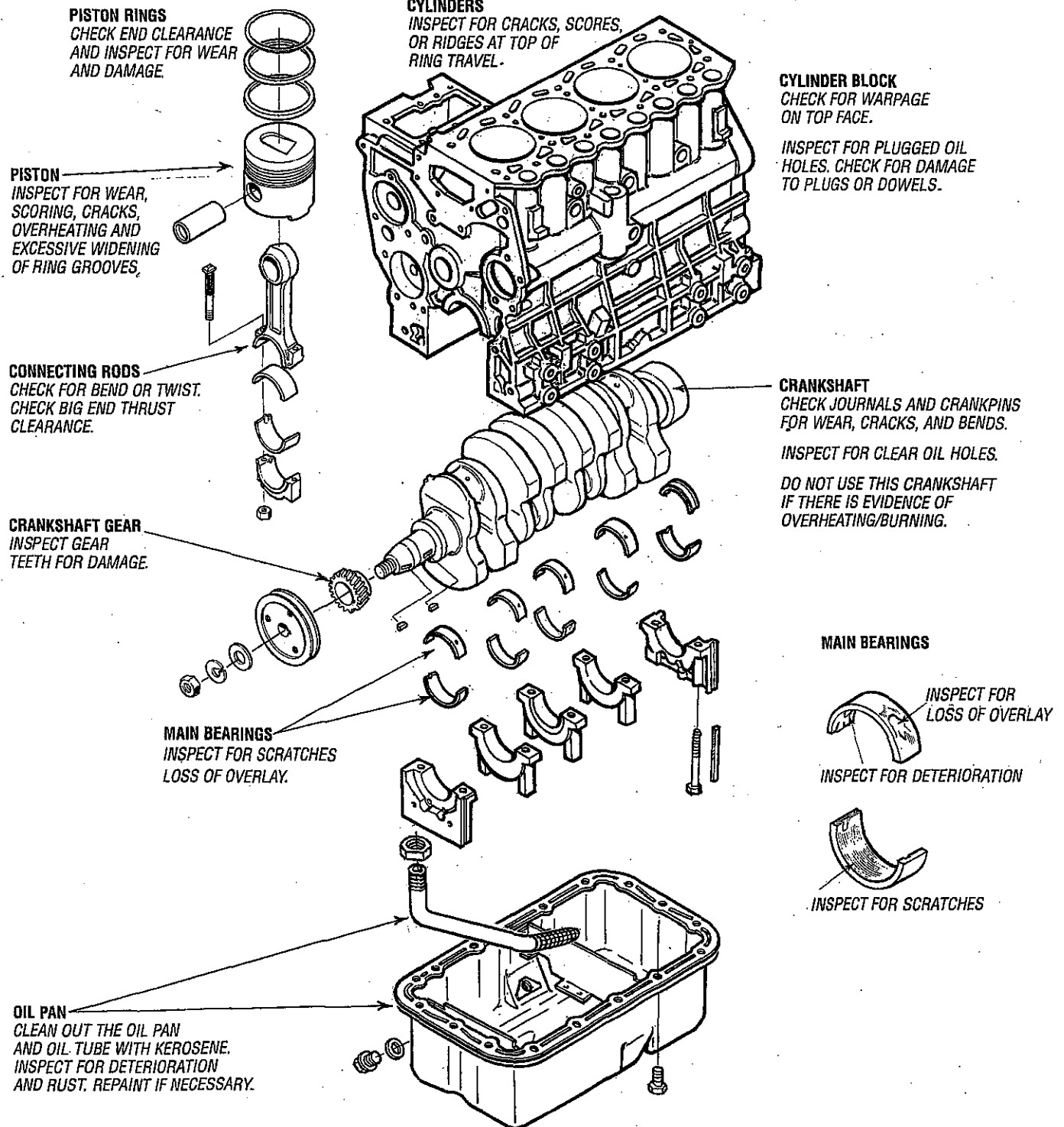

# INSPECTION

d. Put the piston ring in a gauge or in the bore in a new cylinder block and measure the clearance between the ends of the ring with a feeler gauge as shown. If the clearance exceeds the limit, replace all the rings.

## INSIDE DIAMETER OF GAUGE

STANDARD	3.07 <sup>+0.0012</sup> in (78 <sup>+0.03</sup> mm)
OVERSIZE	3.08 <sup>+0.0012</sup> in (78.25 <sup>+0.03</sup> mm) (0.0098 in (0.25mm))
OVERSIZE	3.09 <sup>+0.0012</sup> in (78.50 <sup>+0.03</sup> mm) 0.0197 in (0.50mm)

**NOTE:** Put the piston ring in the gauge or cylinder squarely with the piston.

## MEASURING PISTON RING GAP



## CLEARANCE BETWEEN THE ENDS OF THE PISTON RINGS

	STANDARD	LIMIT
NO.1 RING	0.0059 - 0.0118 in (0.15 - 0.30mm)	0.0591 in (1.50mm)
NO.2 RING	0.0059 - 0.0138 in (0.15 - 0.35mm)	0.0591 in (1.50mm)
OIL RING	0.0079 - 0.0157 in (0.20 - 0.40mm)	0.0591 in (1.50mm)

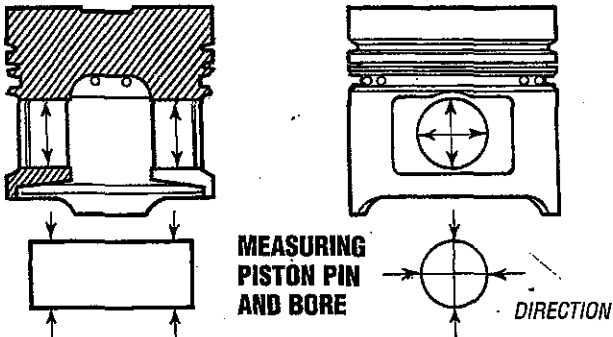

e. Measure the diameter of the piston pin and the bore in the piston for the pin to find the clearance. If the clearance exceeds the limit, replace the piston or pin, whichever is badly worn.

**DIAMETER OF THE PISTON PIN (NOMINAL SIZE 0.91 in (23mm))**  
STANDARD 0.90527 - 0.90551 in (22.994 - 23.000mm)

**CLEARANCE BETWEEN THE PISTON PIN AND PISTON**  
STANDARD 0.00024 - 0.0071 in (0.006 - 0.018mm)  
LIMIT 0.00197 in (0.050mm)

f. Check the connecting rod for bend or twist as follows:

(1) Measure "C" and "ℓ". If "C" exceed 0.0020 in (0.05mm) per 3.94 in (100mm) of "ℓ", straighten the connecting rod with a press.

## BENDING OR TWIST OF CONNECTING ROD

STANDARD 0.0020 in /3.94 maximum (0.05/100mm)  
LIMIT 0.0059 in /3.94 maximum (0.15/100mm)

(2) Generally, a connecting rod aligner is used to check the connecting rod for bend or twist.

**NOTE:** To check the rod for bend, install the cap to the connecting rod and tighten the cap nuts to the specified torque.

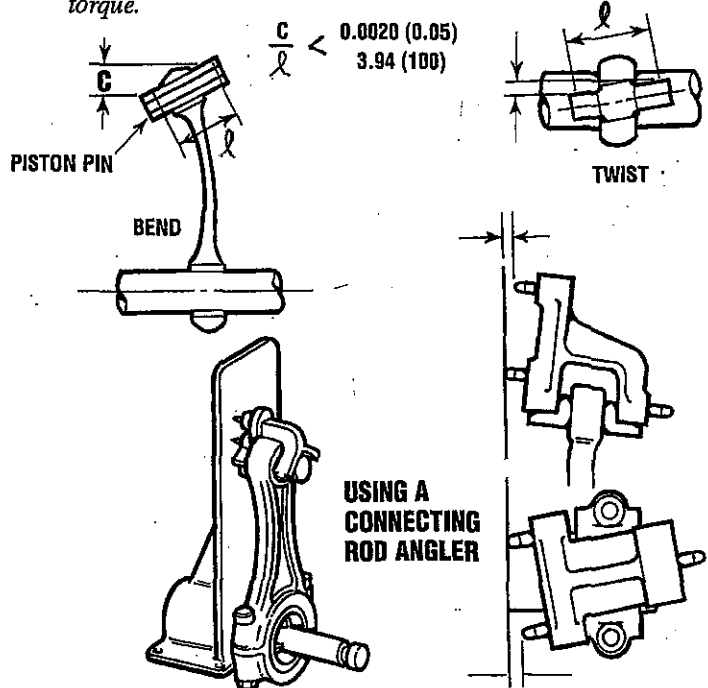

(3) To check the connecting rod fitted to the piston for bend, put the connecting rod and piston on the surface plate as shown, insert a round bar having a diameter equal to that of the crankpin into the bore in the big end of the rod and measure "A" and "B" with a dial indicator. Subtract "A" from "B" to find the bend ("C").

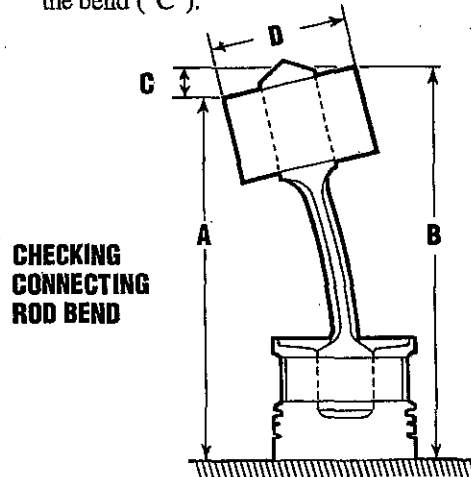

# INSPECTION

## 16. Crankshaft

- a. Clearance between crankpin and connecting rod bearing.

(1) Install the bearing (upper and lower halves) and cap to the big end of the connecting rod and tighten the cap nuts to the specified torque. Measure the bore in the bearing for crankpin as shown.

### TIGHTENING TORQUE

25.7 ± 1.8 lb-ft  
3.55 ± 0.25 Kg-f  
34.8 ± 2.5 Nm

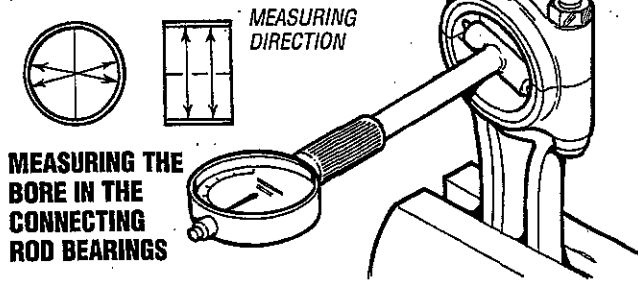

(2) Measure the diameter of the crankpin to find the clearance between the crankpin and connecting rod bearing.

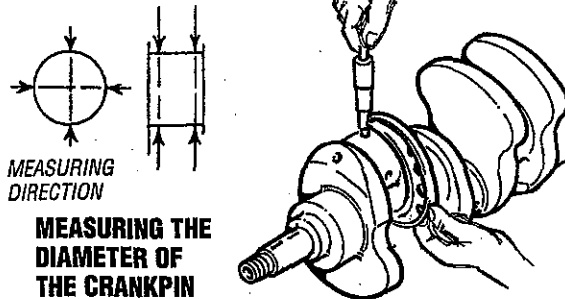

**DIAMETER OF CRANKPIN (NORMAL SIZE 1.89 in (48mm))**

STANDARD 1.88779 - 1.88838 in (47.950 - 47.965mm)

**CLEARANCE BETWEEN THE CRANKPIN AND THE CONNECTING ROD BEARING**

STANDARD 0.00098 - 0.00283 in (0.025 - 0.072mm)  
LIMIT 0.00591 in (0.150mm)

- (3) If the clearance exceeds the limit, install a new bearing and check the clearance again.
- (4) If the clearance still exceeds the limit, grind the crankpin to 0.25mm (0.0098 in), 0.50mm (0.0197 in) or 0.75mm (0.0295 in) undersize and use a undersize connecting rod bearing.

### CRANKPIN UNDERSIZES

0.25mm (0.0098 in)  
FINISH 47.75<sup>-0.050</sup> mm (1.8799<sup>-0.00197</sup> in)

0.50mm (0.0197 in)  
FINISH 47.50<sup>-0.050</sup> mm (1.8701<sup>-0.00197</sup> in)

0.75mm (0.0295 in)  
FINISH 47.25<sup>-0.050</sup> mm (1.8602<sup>-0.00197</sup> in)

**CAUTION: Grind all the crankpins of one crankshaft to the same undersize. Finish the crankpin fillets to a radius of 0.098 in (2.5mm).**

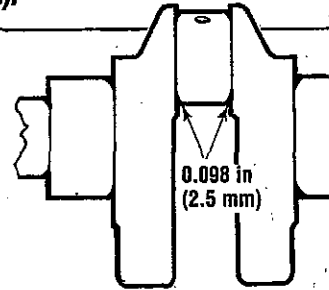

- a. Inspect the clearance between the journal and the main bearing.

(1) Install the main bearing (upper and lower halves) and the cap to the cylinder block and tighten the cap bolts to the specified torque. Measure the bore in the bearing for the journal.

TIGHTENING TORQUE : 38 ± 1.8 lb-ft (5.25 ± 0.25 kg-m)

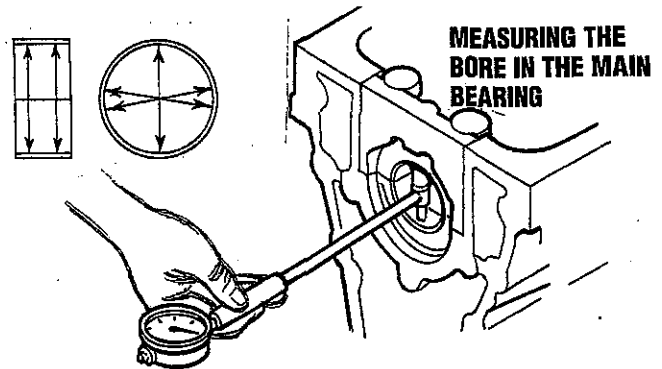

(2) Measure the diameter of the journal as shown to find the clearance between the journal and main bearing.

**DIAMETER OF JOURNAL (STANDARD)**

NOMINAL SIZE 2.05 in (52mm)

STANDARD 2.04665 - 2.04724 in (51.985 - 52.000mm)

**CLEARANCE BETWEEN JOURNAL AND MAIN BEARING**

STANDARD 0.00118 - 0.00303 in (0.030 - 0.077mm)

LIMIT 0.00394 in (0.100mm)

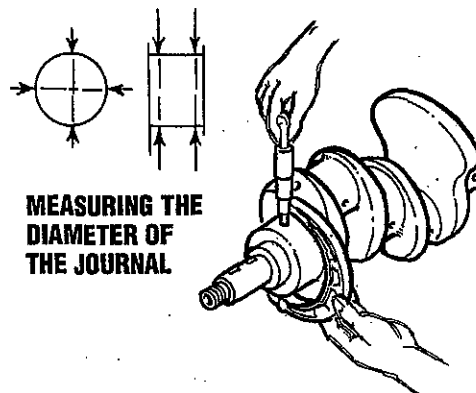

# INSPECTION

- (3) If the clearance exceeds the limit, install a new bearing and check the clearance again.
- (4) If the clearance still exceeds the limit, grind the journal to 0.25mm (0.0098 in), 0.50mm (0.0197 in) or 0.75mm (0.0295 in) undersize and use undersize main bearing.

## JOURNAL UNDERSIZES

0.25mm (0.0098 in)	
FINISH	51.75 <sup>-0.015</sup> mm (2.0374 <sup>-0.00059</sup> in)
0.50mm (0.0197 in)	
FINISH	51.50 <sup>-0.015</sup> mm (2.0276 <sup>-0.00059</sup> in)
0.75mm (0.0295 in)	
FINISH	51.25 <sup>-0.015</sup> mm (2.0177 <sup>-0.00059</sup> in)

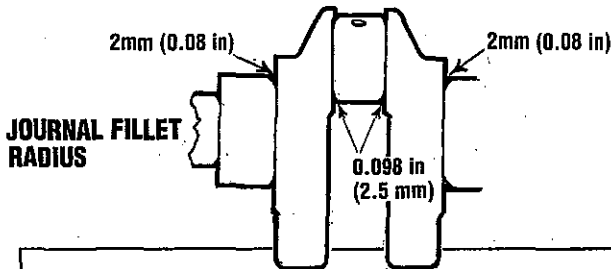

**CAUTION:** Grind all the crankpins of one crankshaft to the same undersize. Finish the crankpin fillets to a radius of 0.08 in (2.0mm).

- (5) Support the crankshaft on its front and rear journals in V-blocks or in a lathe and check the runout at the center journal with a dial indicator. Depending on the amount of runout, repair the crankshaft by grinding or by straightening with a press. If runout exceeds the limit, replace the crankshaft.

## CRANKSHAFT RUNOUT

STANDARD	0.00098 in (0.025mm)
LIMIT	0.0020 in (0.05mm)

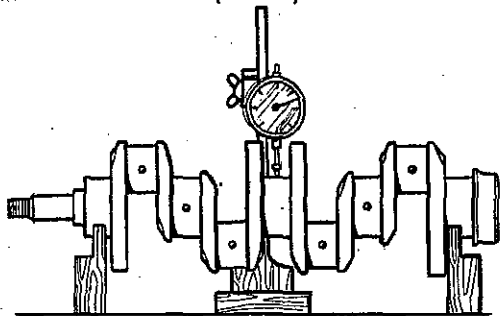

- (6) Use a gear puller to remove the gear from the crankshaft.

**NOTE:** Do not remove the gear unless the gear or crankshaft is defective.

- (7) Installation of the crankshaft gear. Install the key in position on the crankshaft. Install the gear in position with its keyway in alignment with the key.

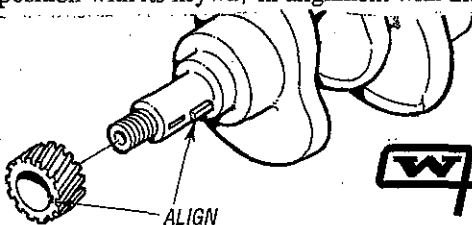

## 17. Cylinder Block

- a. Measure the bore at the top, middle and bottom points on axes A and B with a cylinder bore gauge. If any one of the cylinders exceeds the limit, hone out all the bores for oversize pistons.

PISTON AND PISTON RING	BORE	LIMIT
STANDARD	3.07 in <sup>+0.0012</sup>	+0.0008 in
CODE: STD	(78mm <sup>+0.03</sup> )	(+0.2mm)
OVERSIZE	3.0807 in <sup>+0.0012</sup>	+0.0008 in
0.0098 in (0.25mm)	(78.25mm <sup>+0.03</sup> )	(+0.2mm)
CODE: 25		
OVERSIZE	3.0905 in <sup>+0.0012</sup>	+0.0008 in
0.0197 in (0.50mm)	(78.50mm <sup>+0.03</sup> )	(+0.2mm)
CODE: 50		

TAPER AND OUT OF ROUND 0.0004 in (0.01mm)

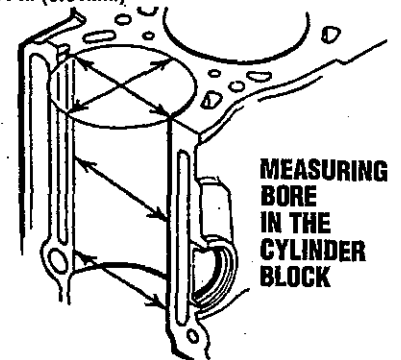
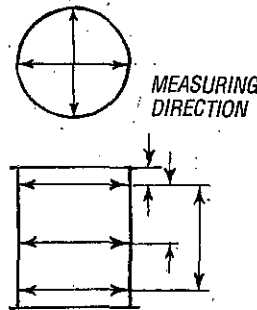

- b. Using a heavy accurate straight edge and a feeler gauge, check the top face for warp in two positions lengthwise, two crosswise and two widthwise. If warpage exceeds the limit, reface the top face with a surface grinder.

WARPAGE OF CYLINDER BLOCK TOP FACE	
STANDARD	0.0020 in (0.05mm)
LIMIT	0.0039 in (0.10mm)

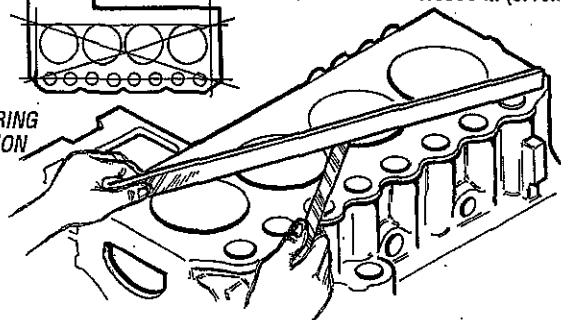
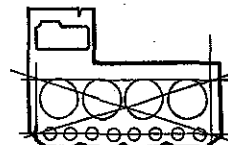

18. Manifold inspection. Using a straight edge and a feeler gauge, check the flange faces of the manifold for warpage. If warpage exceeds the limit, recondition or replace the manifold.

WARPAGE OF THE FLANGE: 0.0059 in (0.15mm)



# ASSEMBLY

## CYLINDER BLOCK, CRANKSHAFT, PISTONS AND OIL PAN

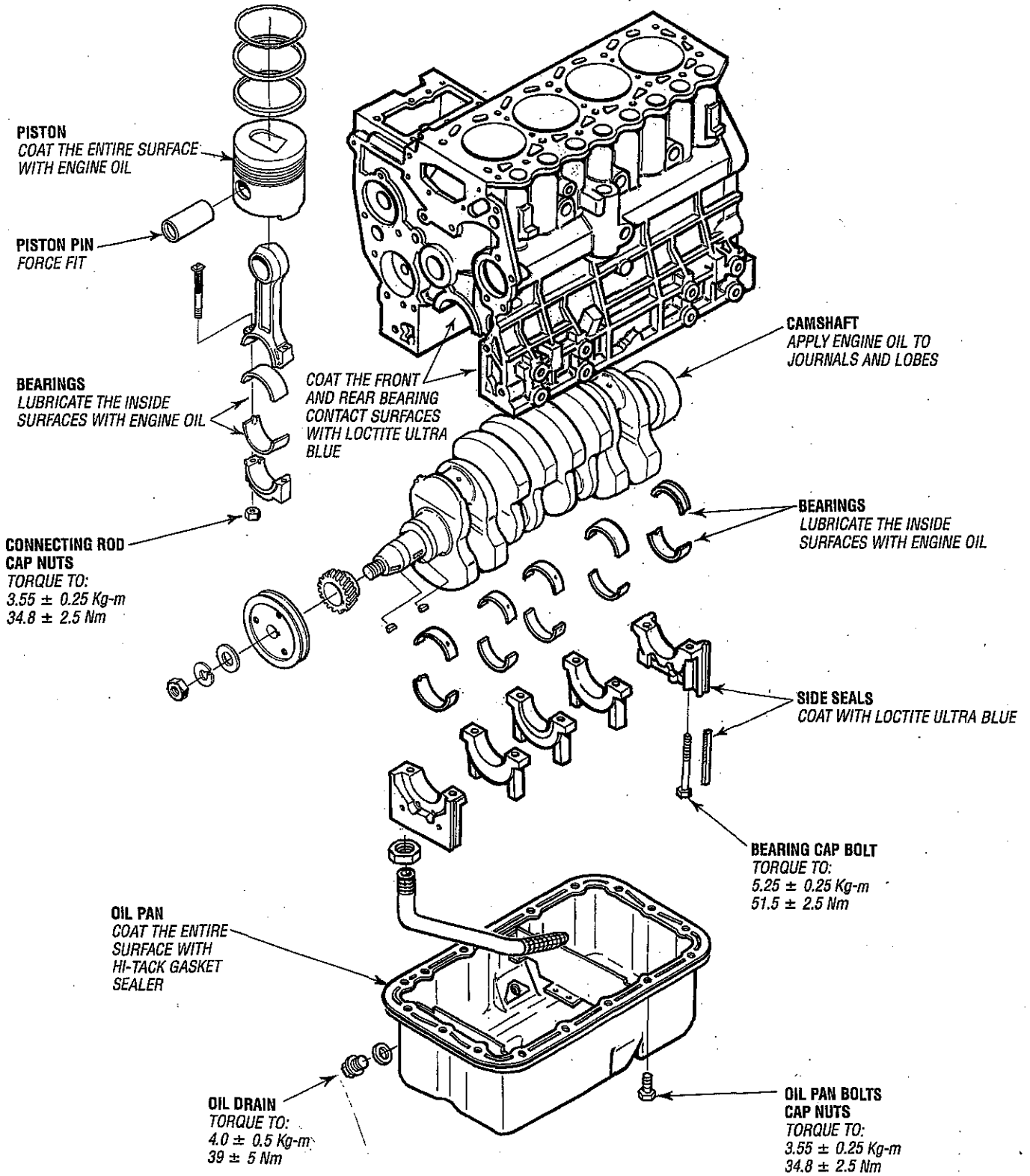

# ASSEMBLY

## 1. Main bearing installation.

- Install the upper halves of the main bearings in the cylinder block and the lower halves in the main bearing caps so their tabs fit into the notches in the cylinder block and the main bearing caps..
- Install the flanged bearing in the No.3 journal.
- Lightly lubricate the inside surfaces of the bearings with engine oil.

**INSTALLING THE MAIN BEARINGS**

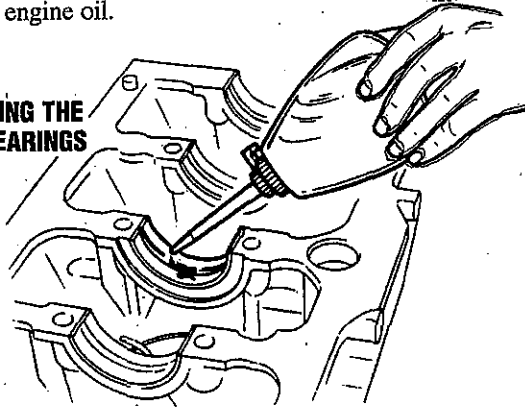

## 2. Crankshaft installation.

- Clean the crankshaft with cleaning solvent and blow dry with compressed air.
- Fasten a hoist to the crankshaft and hold it in horizontal position. Carefully put the crankshaft in position in the cylinder block.
- Lightly lubricate the crankshaft journals with engine oil.

## 3. Main bearing cap installation.

- Coat the mating surfaces of the rear bearing cap and cylinder block with Loctite Ultra Blue.
- Install the main bearing caps in position. Make sure the number (arrow head) on the main bearing cap is toward the front of the engine.
- Tighten the main bearing cap bolts finger tight only.

**CAUTION:** Install the front and rear bearing caps in position so their end faces are even with the end faces of the cylinder block.

- Tighten the bolts holding the main bearing caps in steps to the specified torque.

**TORQUE:** 38 ± 2 lb-ft (5.25 ± 0.25 Kgf-m)

- Make sure the crankshaft rotates freely without binding or catching.
- Measure the end play for the crankshaft. Make reference to *End play measurement* for crankshaft. If the end play is incorrect, loosen the bolts holding the main bearing caps once and tighten them again.

## 4. Side seal installation.

- Coat the side seals with Loctite Ultra Blue.
- Insert the side seals between the cylinder block and the front and rear caps and push them in by hand as far as possible, with their rounded side toward the outside of the cylinder block.
- Using a flat plate, push the seals into position, taking care not to bend them.

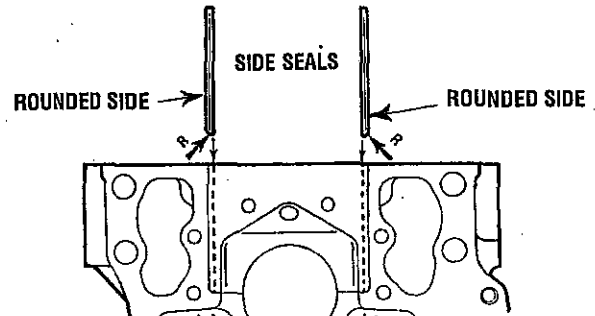

## 5. Piston assembling to connecting rod.

- Set Piston Setting Tool (special tool) in a hydraulic (l) in press.
- Put the connecting rod on the Tool and lubricate the bore in the rod for the piston pin with engine oil.
- Put the piston in position on the connecting rod, making sure the model identification on the rod is on the same side as the arrow head on the top of the piston. Put the piston pin in position.
- Insert the push rod of the Tool into the bore in the piston for the piston pin and press the pin with the press.

**CAUTION:** Observe the indicator of the press when pressing the piston pin. If the force of the press is ready to exceed 50kgf (110 lbf) [490N], stop pressing the pin and check the bores in the piston and connecting rod for alignment.

- After assembling the piston and connecting rod, make sure the connecting rod moves freely.

## 6. Using a piston ring pliers, install the piston rings on the piston.

**NOTE:** The piston rings must be installed with the side that has the mark "T" toward the top of the piston. The oil ring must be installed with the coil ring end gap 180° apart from the coil spring joint.

**INSTALLING THE PISTON RINGS**

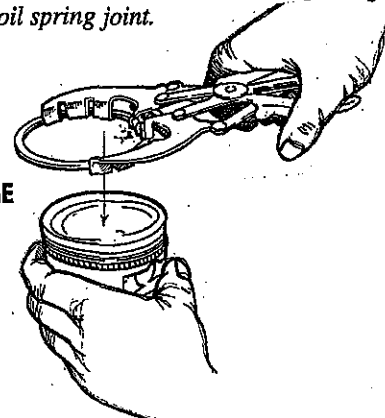

# ASSEMBLY

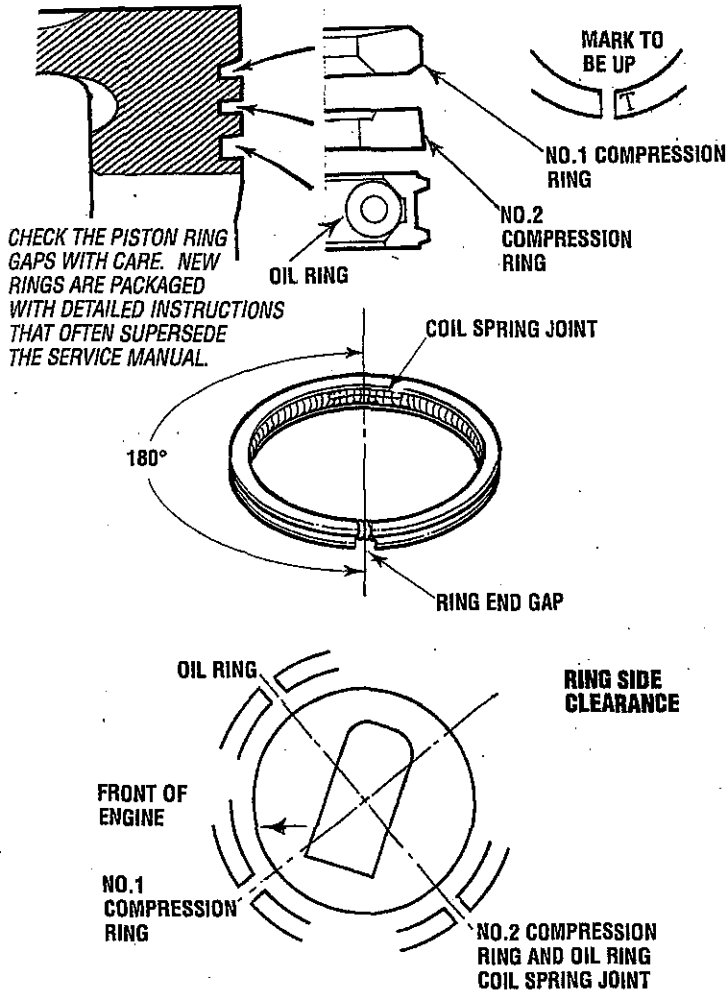

## 7. Piston and connecting rod installation.

- Lubricate the piston and piston rings with engine oil.
- Move the piston rings on the piston so that the end gaps are apart from a direction parallel to, or traverse to, the piston pin.
- Install the connecting rod bearing (upper half) to the rod, making sure the tab in the back of the bearing is in the notch of the connecting rod.
- Turn the crankshaft until the crankpin for the piston and connecting rod to be installed is at the top center.
- Hold the piston and connecting rod with "FRONT" mark (arrow head) on the top of the piston toward the front (timing gear case side) of the engine.
- Using a piston guide (commercially available), put the piston and connecting rod into the cylinder from the top of the cylinder block.

**CAUTION:** Do not use a hammer when installing the piston and connecting rod as this will damage the piston rings and crankpin.

## 8. Connecting rod cap installation.

- Push the piston into position until the big end of the connecting rod is put into position over the crankpin. Then turn the crankshaft 180° while pushing on the top of the piston.
- Install the lower half of the connecting rod bearing in the connecting rod cap, making sure the tab in the back of the bearing is in the notch of the cap.
- Install the bearing cap to the connecting rod.

**NOTE:** Make sure the number on the cap is the same as the number on the connecting rod. In case of a new connecting rod having no cylinder number, install the cap to the rod with the notches on the same side.

- Tighten the connecting rod cap nuts in steps to the specified torque.

**TORQUE:** 25.7 ± 2 lb-ft (3.55 ± 0.25 Kgf-m)

- Check the thrust clearance for the connecting rod big end.

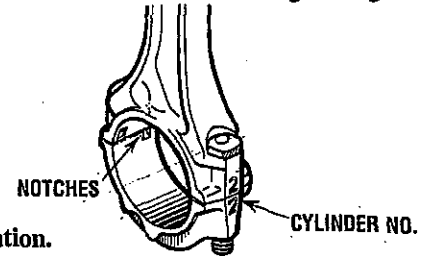

## 9. Oil screen installation.

- Lay the cylinder block with the bottom (oil pan side) up.
- Install the oil screen in position.

**NOTE:** The oil screen must be installed in position so that it is below the oil level line and away from the oil pan.

**10. Oil pan installation.** Clean the mating surfaces of the oil pan and cylinder block and coat them with Hi-Tack Gasket Sealer. Tighten the bolts that hold the oil pan to the cylinder block in a crisscross pattern to the specified torque.

**TORQUE:** 8.3 ± 1.1 lb-ft (1.15 ± 0.15 Kgf-m)

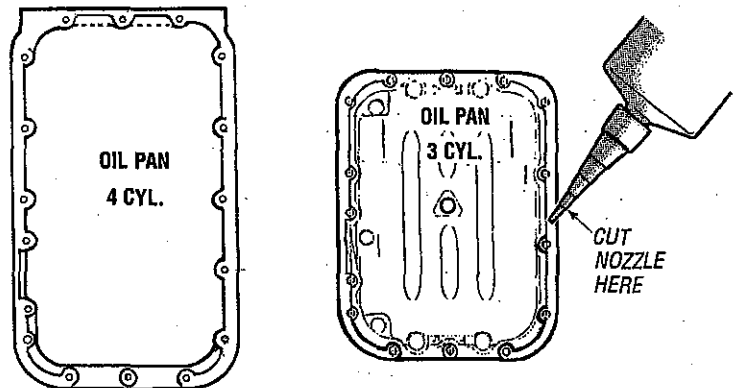

**NOTE:** Squeeze out a 4mm (0.2 in) thick bar of sealing compound Hi-Tack Gasket sealer from the tube and put it on the flange of the oil pan as shown. To squeeze out a 4mm (0.2 in) thick bar, cut the nozzle of the tube as shown.

# ASSEMBLY

## TIMING GEARS AND FLYWHEEL

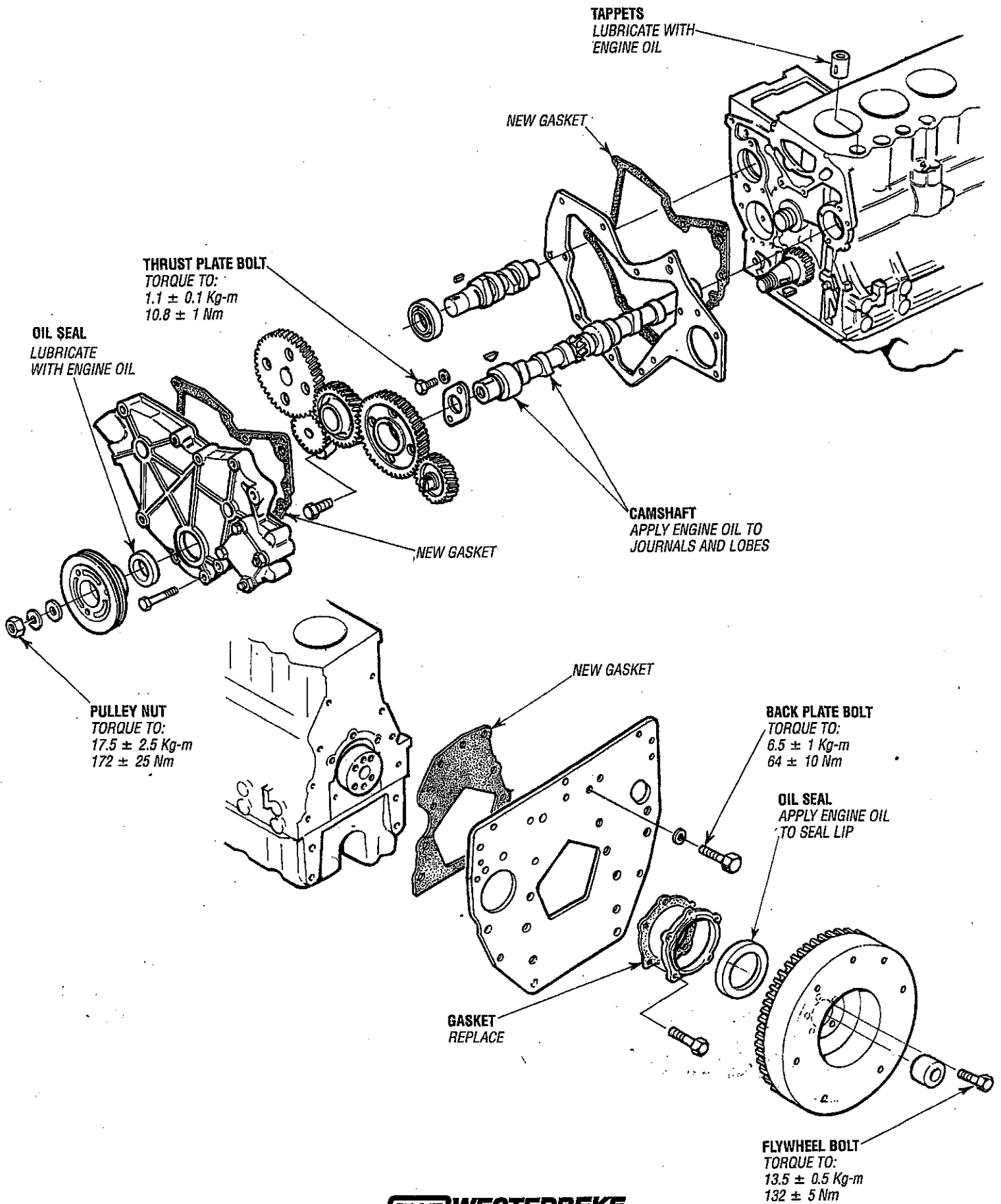

# ASSEMBLY

## 11. Front plate installation.

- Scrape the gasket from the cylinder block and front plate.
- Coat the gasket contact surface of the cylinder block with adhesive and put a new gasket in position, making sure the holes in the gasket are all in alignment with the holes in the cylinder block.
- Put the front plate in position. Install four bolts and tighten them.

## 12. Oil pump installation.

- Make sure the packing has been put in position on the oil pump.
- Put the oil pump in position on the cylinder block. Install the bolts and tighten them evenly.
- Make sure the oil pump gear rotates freely.

## 13. Engine turning.

- Install two bolts (M12 x 1.25) in the flywheel bolts holes in the crankshaft.
- Put a bar between the bolts and turn the crankshaft to bring No.1 piston to the top center as shown in the illustration.

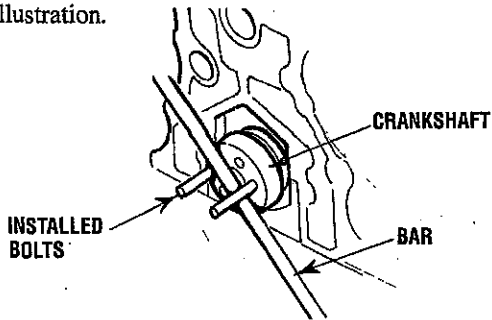

## 14. Fuel injection pump camshaft installation.

- Put the camshaft (with bearing and gear) in position in the cylinder block.
- Hit the gear with a plastic hammer to fit the bearing in position.
- Make sure the camshaft rotates freely.
- Tighten the stopper bolt.

## 15. Camshaft installation.

- Lubricate the lobes and journals with engine oil.
- Put the camshaft (with gear) in position in the cylinder block.

**CAUTION:** Do not cause damage to the lobes and journals when the camshaft is installed.

- Tighten the bolts that hold the thrust plate to the specified torque.

**TORQUE:**  $8 \pm 0.7$  lb-ft ( $1.1 \pm 0.1$  Kgf-m)

- Make sure the camshaft rotates freely. Check the end play for the camshaft.

## IDLER GEAR INSTALLATION

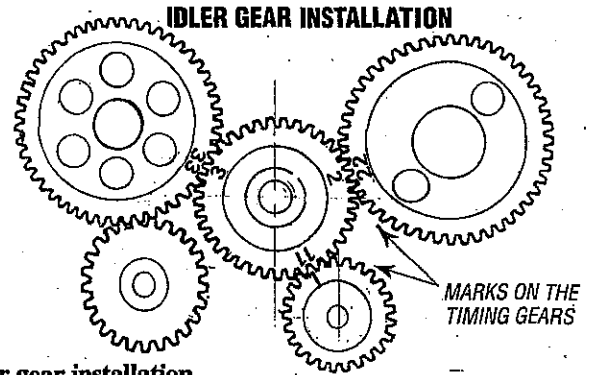

## 16. Idler gear installation.

- Lubricate the idler gear with engine oil.
- Install the idler gear in position with its "3", "2" and "11" marks in alignment with the the "33" mark on the fuel injection pump camshaft gear, the "22" mark on the camshaft gear and the "1" mark on the crankshaft gear respectively.
- Check the backlash of the gears. Make reference to *Timing gear backlash measurement*.

## 17. Timing gear case installation.

- Coat the gasket with adhesive and put it in position on the front plate.
- Lubricate the oil seal with engine oil.
- Tighten the bolts that hold the timing gear case.

## 18. Crankshaft pulley nut tightening.

- Install two bolts (M12 x 1.25) in the flywheel bolt holes in the crankshaft and hold the crankshaft.
- Tighten the crankshaft pulley nut to the specified torque.

**TORQUE:**  $127 \pm 18$  lb-ft ( $17.5 \pm 2.5$  Kgf-m)

**WARNING:** Check the strength of the bolts and bar used for holding the crankshaft.

- P.T.O. gear installation.** Install the P.T.O. gear in position in the timing gear case with the side that has no oil hole toward the rear of the engine.

- Tappet installation.** Lubricate the tappets with engine oil and put them in position in the cylinder block.

## 21. Oil seal case installation.

- Put a new gasket in position on the oil seal case.
- Lubricate the oil seal with engine oil and install the oil seal in position in the cylinder block.

## 22. Rear plate installation.

- Put a new gasket in position on the rear plate.
- Put the rear plate in position on the cylinder block with its dowel holes in alignment with the dowels. Tighten the bolts that hold the rear plate to the specified torque.

**TORQUE:**  $47 \pm 7$  lb-ft ( $6.5 \pm 1$  Kgf-m)

**NOTE:** Install the starter to the rear plate before installing the plate to the cylinder block for convenience of rear plate installation.

# ASSEMBLY

## 23. Flywheel installation.

- Install a safety bar (M12x 1.25) in the rear end of the crankshaft.
- Put the flywheel in position in alignment with the safety bar.
- Install three of four bolts in the flywheel and tighten them finger tight only.
- Remove the safety bar. Install the last bolt in the fly wheel and tighten it finger tight only.
- Have someone hold the crankshaft pulley with a wrench to prevent the flywheel from rotating.
- Tighten the four bolts that hold the flywheel to the specified torque.

TORQUE:  $98 \pm 4$  lb-ft ( $13.5 \pm 0.5$  Kgf-m)

**WARNING:** Always signal to each other to prevent possible personal injury.

## CYLINDER HEAD AND VALVE MECHANISM

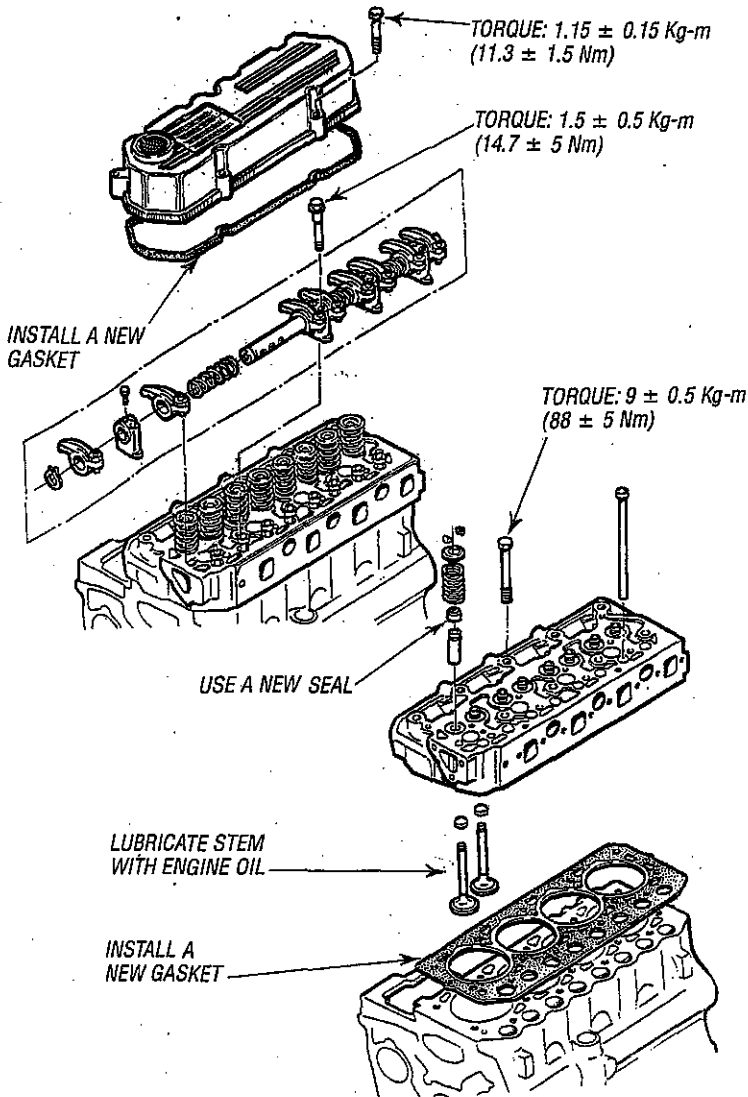

## 24. Cylinder head bottom face cleaning. Scrape the gasket from the bottom face of the cylinder head.

**NOTE:** After scraping the gasket, rub off gasket remnants from the face with an oilstone smeared with engine oil and thoroughly clean the face.

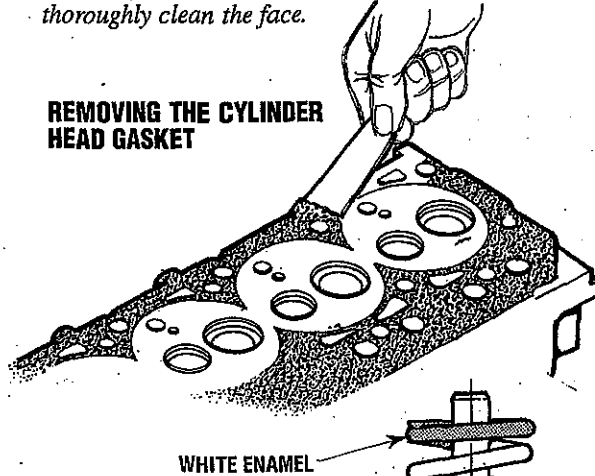

## INSTALLING THE VALVE SPRING

## 25. Valve stem seal installation. Install the valve stem seal in position in the valve guide. After installation, make sure the seal is in its correct position.

**NOTE:** Improper stem seal installation can cause a failure to seal against downward flow of oil along the stem.

## 26. Install the valve spring with the white enameled end up.

## 27. Valve block installation. Put compression on the valve spring with a valve lifter and install the block in position on the valve top.

**CAUTION:** Do not put excessive compression on the valve spring. This can cause the retainer to hit and damage the stem seal.

## 28. Cylinder head gasket installation.

- Thoroughly clean the top faces of the cylinder block and pistons,
- Install two guide bolts (M10 x 1.25) in the bolt holes in the cylinder block.
- Put a new cylinder head gasket in position on the cylinder block, making sure the guide bolts are all in alignment with their respective holes in the gasket..

**CAUTION:** Do not use any gasket adhesive or other substances on the top face of the cylinder block.

# ASSEMBLY

**29. Installation of the cylinder head.** Place the cylinder head in position on the cylinder block, making sure the guide bolts are all in alignment with their respective bolt holes in the head.

**30. Cylinder head bolt tightening**

- Remove the guide bolts and install the bolts that hold the cylinder head to the cylinder block.
- Tighten the bolts in number sequence in two or three steps to the specified torque.

TORQUE:  $65 \pm 4$  lb-ft ( $9 \pm 0.5$  Kgf-m)

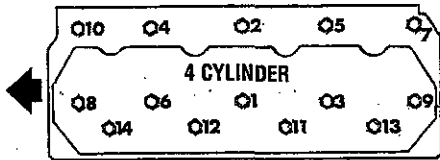

FRONT

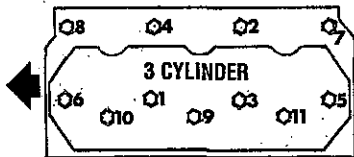

**31. Valve push rod installation.**

- Put the valve push rod into position through the bore in the cylinder head.
- Make sure the ball end of the push rod has been put into position over the top of the tappet.

**32. Rocker shaft assembly.**

- Install the rocker arms, brackets and springs on the rocker shaft. Secure the brackets to the shaft by tightening the bolts.
- Make sure the rocker arms move freely.

**33. Rocker shaft assembly installation.**

- Install the valve caps in position on the top of the valves.
- Put the rocker shaft assembly in position on the cylinder head. Tighten the bolts that hold the rocker shaft assembly to the specified torque.

TORQUE:  $11 \pm 4$  lb-ft ( $1.5 \pm 0.5$  Kgf-m)

- Adjust the valve clearance, see *VALVE CLEARANCE* in this manual.

**34. Rocker cover installation.**

- Make sure the gasket is assembled to the rocker cover,
- Tighten the bolts that hold the rocker cover to the specified torque.

TORQUE:  $8.3 \pm 1.1$  lb-ft ( $11.5 \pm 0.15$  Kgf-m)

**35. Tighten the bolts that hold the air intake to the specified torque.**

TORQUE:  $13.4 \pm 2.5$  lb-ft ( $1.85 \pm 0.35$  Kgf-m)

**36. Tighten the bolts that hold the exhaust manifold to the specified torque.**

TORQUE:  $13.4 \pm 2.5$  lb-ft ( $1.85 \pm 0.35$  Kgf-m)

**37. Fuel injection nozzle installation.**

- Put the gasket on the nozzle.
- Put the nozzle assembly in position in the cylinder head and tighten it to the specified torque.

TORQUE:  $40 \pm 4$  lb-ft ( $5.5 \pm 0.5$  Kgf-m)

**38. Put the fuel injection pump in position on the cylinder block and tighten the bolts that hold the pump to the specified torque.**

**39. Put the flywheel assembly in position on the rear end of the fuel injection pump camshaft and tighten the sliding sleeve shaft to the specified torque.**

TORQUE:  $26 \pm 4.3$  lb-ft ( $3.6 \pm 0.6$  Kgf-m)

**40. Install the sliding sleeve on the sliding sleeve shaft and make sure the sleeve moves freely.**

**41. Fuel injection nozzle installation.**

- Install the governor assembly in position while putting the tie rod and spring into position in the injection pump.
- Install the tie rod to the pin of the control rack and secure it with the tie rod spring.
- Install the tie rod cover in position.

**42. Fuel injection line installation.**

- Put the fuel leak-off in position and connect it to the fuel injection nozzles.
- Put the fuel injection lines in position and connect them to the fuel injection pump. Install the clamps.

**43. Pressure relief valve installation.** Put the relief valve in position on the cylinder block and tighten it to the specified torque.

TORQUE:  $36 \pm 4$  lb-ft ( $5 \pm 0.5$  Kgf-m)

**44. Install the oil filter.** Lightly lubricate the gasket with engine oil and install the new filter element by hand. When the gasket contacts the base, tighten one more turn.

**45. Coolant pump.** Check the impeller and shaft for rotation. If they do not rotate freely or have noise, replace the coolant pump assembly.

**46. Put a new gasket in position on the water pump flange.** Install the water pump onto the cylinder block.

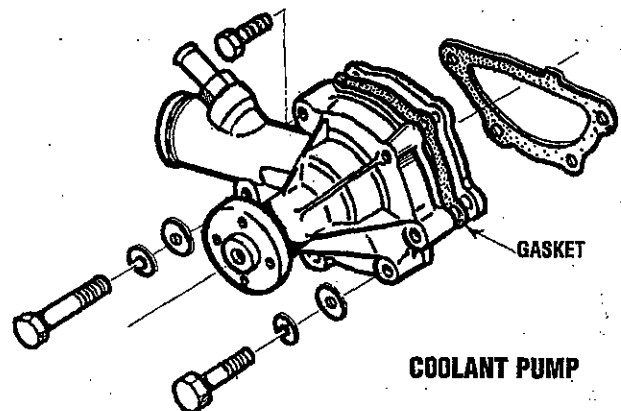

# ASSEMBLY

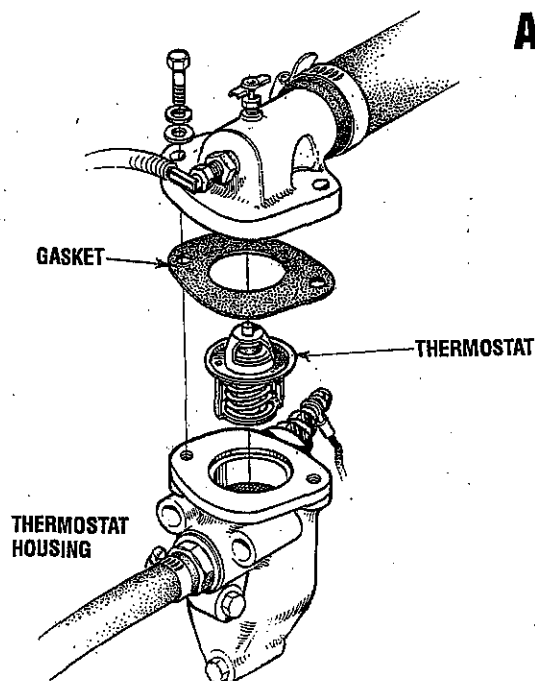

47. **Install the thermostat.** Put the thermostat in the thermostat housing with a new gasket and install the thermostat housing in position on the cylinder head.

48. **Oil pump.** Visually check the pump for rough rotation or other defects. Replace the pump assembly if defective.

49. **Oil pressure relief valve.** Check the valve seat for contact and check the spring for damage. Measure the oil pressure at which the relief valve opens (the oil pressure with the engine running at the rated rpm). If the pressure is not correct, remove the cap nut and increase or decrease the amount of shims. The engine oil pressure tap is located on the right side of the engine.

RELIEF VALVE OPENING PRESSURE:  $50 \pm 7$  psi ( $3.5 \pm 0.5$  Kgf-m)

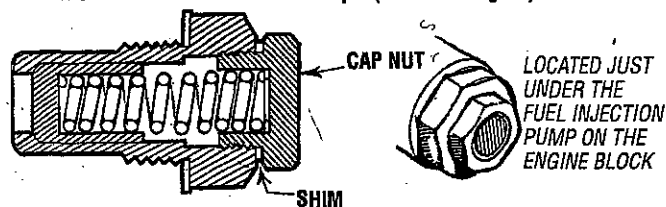

50. **Install the glow plugs in position in the precombustion chamber and tighten them to the specified torque. For testing, refer to GLOW PLUGS in this manual.**

TORQUE:  $12.7 \pm 1.8$  psi ( $1.75 \pm 0.25$  Kgf-m)

51. **Alternator installation.**

- Put the alternator in position. Install the adjusting bolt in position to hold the alternator in position.
- Put the belt in position on the pulley. Move the alternator away from the engine to make an adjustment to the belt.
- Tighten the bolts.
- Make sure the tension of the belt is correct, about 1/2" deflection at the center with pressure.

52. **Fuel run solenoid installation [if applicable].**

- Remove the tie rod cover.
- Coat the threads of the stop solenoid with thread sealant (Three Bond 1212). Coat the length of the threads to be turned in the governor case.
- Temporarily install the shutoff solenoid and nut in the governor case.
- Move the injection pump control rack all the way to the non-injection (shutoff) position.
- Turn the shutoff solenoid in the governor case while pushing the plunger toward the control rack until the shaft is in touch with the tie rod. At this time, clearance C must be 0 mm. (Under this condition, the plunger will be rotated by the shutoff solenoid being turned in).
- Back off the shutoff solenoid  $30^\circ$  to  $45^\circ$  turn (the clearance between the control rack and plunger will be 0.15 to 0.20 mm (0.0059 to 0.0079in) and tighten the nut to the specified torque.
- Start the engine and make sure the engine stops when the plunger is pushed all the way.
- Stop the engine and make certain the engine stops when the start key is turned to the off position.

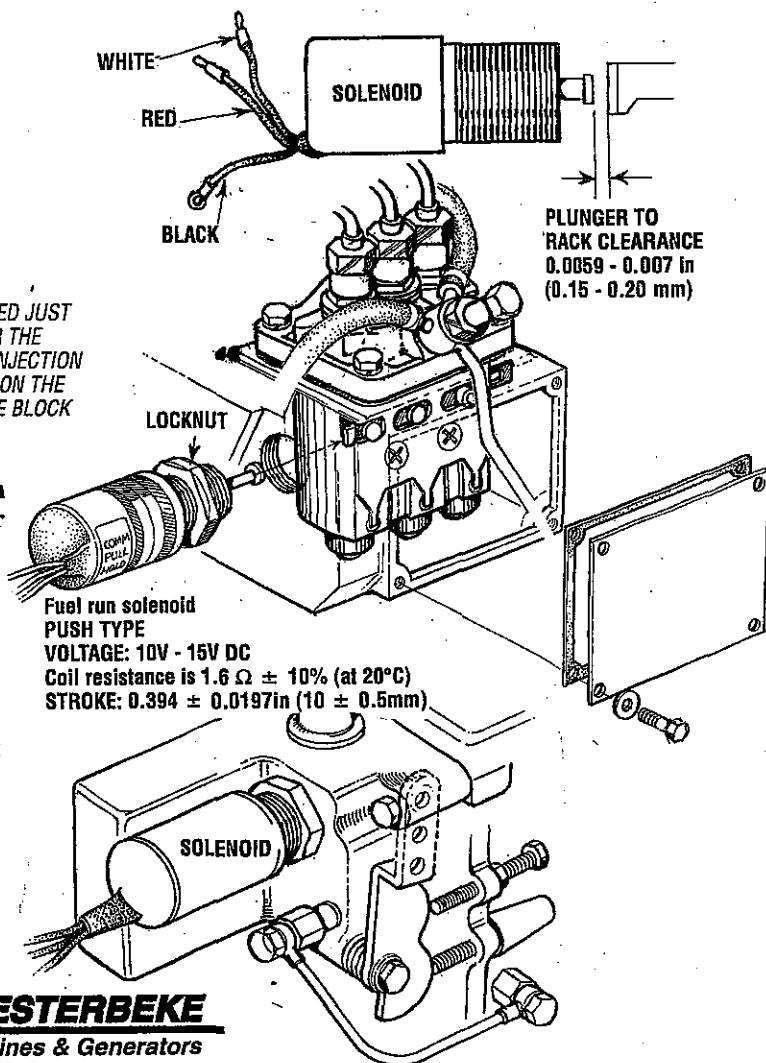



# EXHAUST MANIFOLD / HEAT EXCHANGER

## EXHAUST MANIFOLD

The exhaust manifold, which was disassembled from the cylinder head, should be inspected before reassembly.

1. Remove the exhaust elbows from the lower surface of the manifold. Clean and inspect for cracks and defects. Replace as needed.
2. Remove the exhaust nipples, elbows and plugs from the manifold.
3. Remove water connectors from the ends of the manifold. Be sure to note the proper location and arrangement of each for proper alignment.
4. Examine all parts for defects, corrosion and wear and replace as needed.
5. Flush out the manifolds interior with a liquid cleaner and rinse thoroughly with fresh water.
6. Use a pipe cleaner to clear the passage that connects the coolant recovery tank tubing.
7. Flush out the coolant recovery tank and it's connecting tube.

## ASSEMBLY

1. If the manifold was removed as an assembly and left intact, it can be replaced on the cylinder head in the reverse order of removal. Do not reuse the gaskets; install new ones.

Manifold Mounting  
Bolts Torque Values 20 - 24 ft-lb (2.7 - 3.3 m-kg)

2. If the manifold has been disassembled, follow the steps below.
  - a. Loosely attach the elbows to the cylinder head and the manifold using new gaskets. Do not use any gasket sealant.
  - b. Gradually tighten each fitting to make sure of proper alignment of all the parts. This should be done in three steps.

Manifold Mounting  
Bolts Torque Values 20 - 24 ft-lb (2.7 - 3.3 m-kg)

- c. Reinstall the exhaust connections and plugs into the manifold using Loctite-Anti-Seize on the threads.

Check the manifold pressure cap. Open the valve by pulling it and make sure it closes when released. Make certain the upper and lower seals are in good condition. If any doubt, replace the cap.

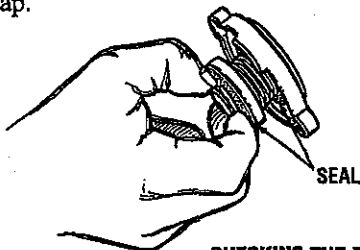

CHECKING THE PRESSURE CAP

## HEAT EXCHANGER

The heat exchanger should be inspected and serviced during an engine overhaul.

1. Disconnect the hoses and remove the hose fittings, petcock, drain plugs and zinc anode. Also, remove the end fittings and gaskets.
2. Inspect the tube (casing) for wear and dents, if at all suspect replace the heat exchanger.
3. Clean out any zinc debris and pressure test the coolant and raw water passages.
4. When reassembling, install new gaskets and O-rings. Apply some lubricant to the new gaskets and to the petcocks and fittings as you install them.
5. Install a new zinc anode.

**NOTE:** All of the above can be accomplished by sending the heat exchanger to a heat exchanger service shop. They will also service transmission and engine oil coolers.

6. Repaint the assembled heat exchanger with Westerbeke heat resistant spray enamel.

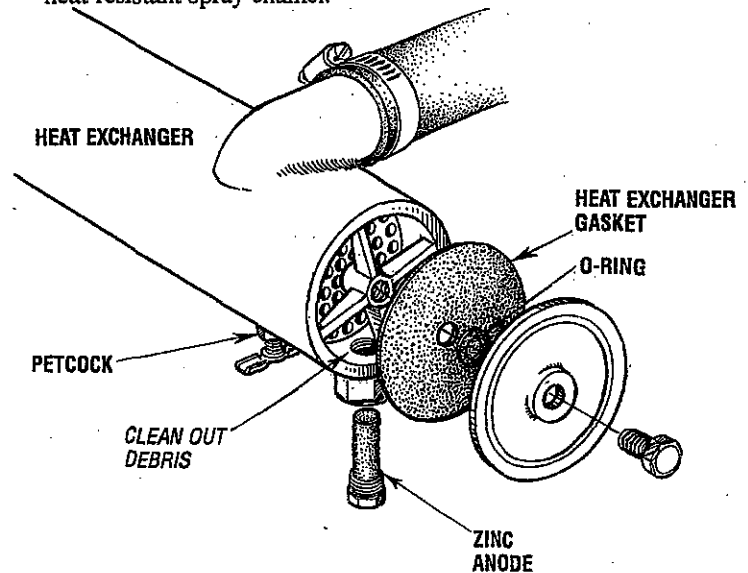

## AFTER COMPLETED ENGINE ASSEMBLY

7. Reconnect all hoses, replacing them as needed.
8. Refill the system with coolant as detailed above.
9. Pressure test system and check for leaks.

# FUEL INJECTION PUMP

**NOTE:** Injector pump servicing should be performed by a qualified injector shop.

## Disassembly Procedure

### 1. Tappet removal.

- Hold the injection pump in a vise with the side that has the tappets up.
- Straighten the lock plate away from the tappet guide pin with a screwdriver.
- Rotate the tappet guide pin 180° to unlock it from the housing.
- Remove the tappet guide pin with a needle-nose pliers while pushing down on the tappet. Remove the tappet.
- Do Steps (b) through (d) again for the remainder of the tappets.

**CAUTION:** The tappet can be thrown from the housing when the tappet guide pin is removed. Hold the tappet to prevent it from falling.

### 2. Plunger removal.

- Remove the tappet adjusting shim.
- Remove the lower spring seat and plunger with a tweezers.
- Remove the plunger spring.
- Remove the upper spring seat and control sleeve.
- Do Steps (b) through (d) again for the remainder of the plungers.
- Remove the control rack.

### 3. Delivery valve removal.

- Turn the injection pump upside down and hold it in a vise.
- Remove the delivery valve holder.
- Remove the delivery valve spring.
- Remove the delivery valve gasket.
- Remove the delivery valve with a tweezers.
- Do Steps (b) through (e) again for the remainder of the delivery valves.
- Remove the barrels from the housing.

**NOTE:** When replacing the plungers and barrels or delivery valves, do not loosen the adjusting plates between the pumping elements.

After these parts have been replaced, the injection quantity must be measured. A Pump Tester Cam Box is needed for the measurement of the injection quantity. Keep the disassembled injection pump parts in clean diesel fuel.

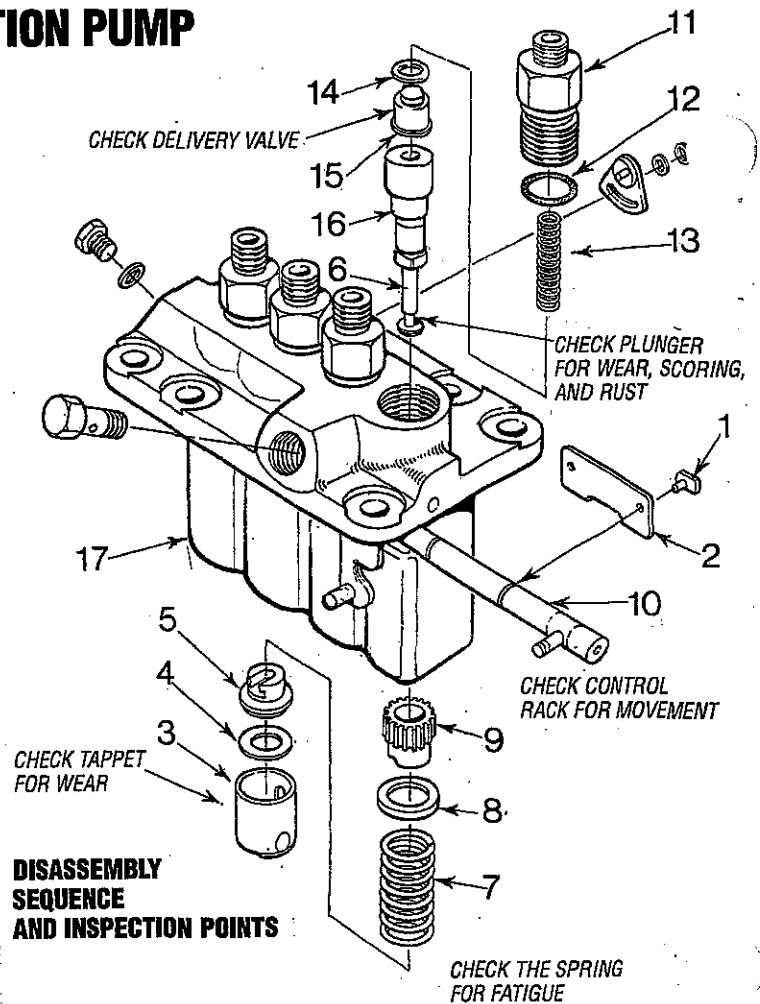

## DISASSEMBLY SEQUENCE AND INSPECTION POINTS

**CAUTION:** The delivery valves, plungers and barrels are finely finished parts. Keep them as clean as possible.

Keep the plungers with their respective barrels for installation. Do not use plungers or barrels with other barrels or plungers.

## Assembly procedure

- Put each barrel in position in the housing with its slot in alignment with the dowel of the housing and put it straight down into the bore.

**NOTE:** If the slot in the barrel is not aligned with the dowel of the housing, the O-ring will not seat correctly (still visible) after the delivery valve holder has been installed.

- Install the delivery valve, gasket, spring and O-ring on the barrel and tighten the delivery valve holder finger tight. Do this step for the remainder of the delivery valves.

**CAUTION:** Anytime the injection pump is disassembled, a new O-ring must be installed. Make sure the threads of the delivery valve holder do not cause damage to the O-rings.

# FUEL INJECTION PUMP

3. Install each control sleeve with the center tooth in alignment with the line mark of the control rack. Put the plungers in position in the barrels.

**CAUTION:** *Make sure the notch in the plunger is toward the adjusting plate*

4. **Tappet installation.** Move the control rack back and forth while pushing down on each tappet to align the slot in the tappet with the hole in the housing for the tappet guide pin. Install the lock plates and tappet guide pins in position.

**CAUTION:** *Anytime the injection pump is disassembled, new lock plates must be used.*

5. Put the delivery valve holders in position and tighten them to the specified torque.

**CAUTION:** *Do not overtighten the delivery valve holders. This can put end force on the barrels, resulting in a failure of the plungers to move freely. If the holders are not tightened to the specified torque, engine oil would leak in the injection pump.*

DELIVERY VALVE HOLDER TORQUE  $4.5 \pm 0.5$  Kg-m ( $44 \pm 5$  Nm)

## 6. Inspection after assembly.

- a. After the injection pump has been assembled, check to see if the control rack moves freely without any binding or catching.
- b. If the control rack fails to move freely, the possible causes are:
- Pumping element(s) sticking.
  - Foreign particles lodged between control rack and sleeves.
  - Overtightening of delivery valve holder(s).  
Disassemble and check the injection pump to locate the cause of the trouble.
- c. After the injection pump has been finally assembled, check the injection timing.

# GOVERNOR

## DISASSEMBLY SEQUENCE AND INSPECTION

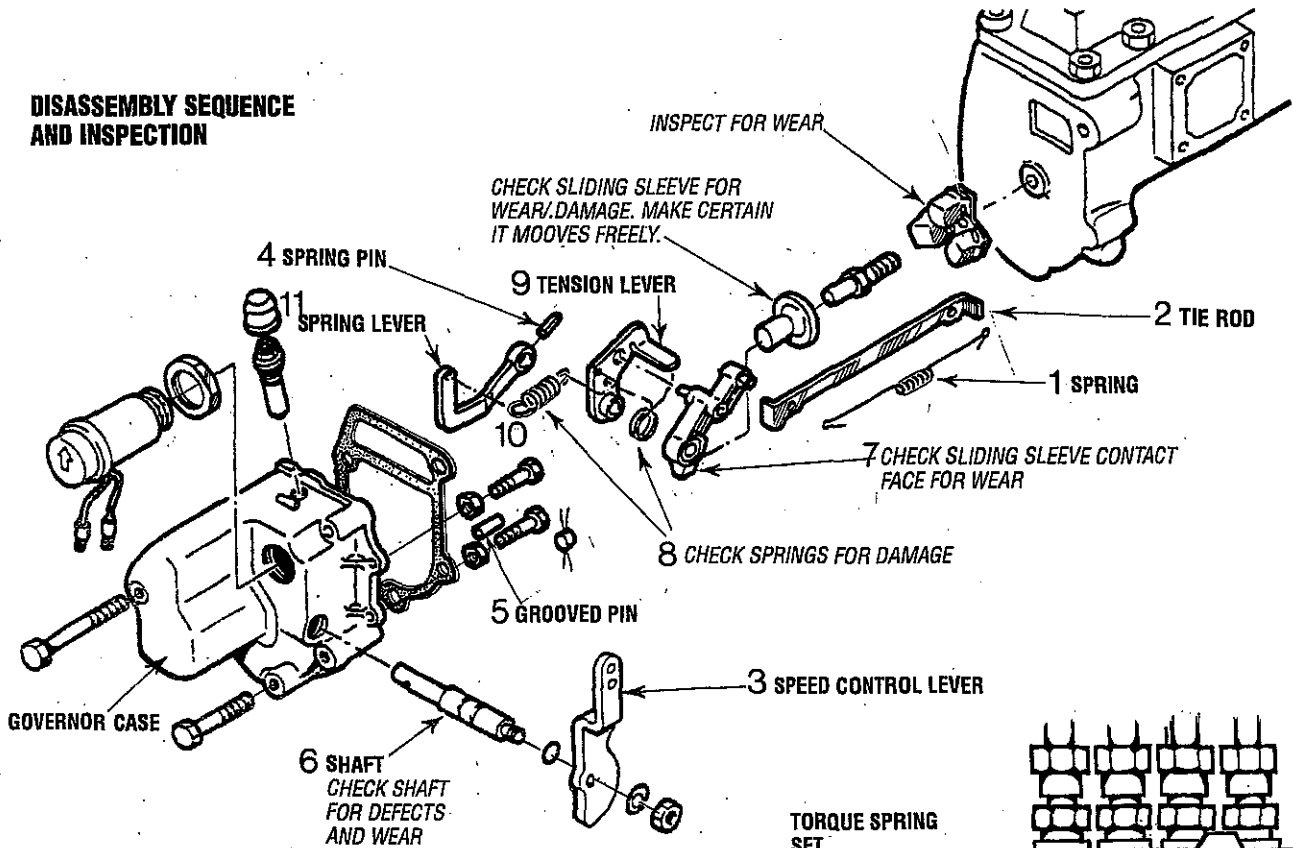

### 1. Assembly.

- a. Install the levers in position.
- b. Put the O-ring on the governor shaft.
- c. Put the governor shaft in position in the governor case and put the levers on the governor shaft.
- d. Install the grooved pin and spring pin in position with a hammer.
- e. Install the tie rod and tie rod spring in position.

### 2. Torque spring set installation.

The torque spring set is to be installed and adjusted after an adjustment is made to the low idle speed and high idle speed, with the engine at a standstill.

- a. Remove the tie rod cover.
- b. Move the speed control lever to the high idle position and hold it there.
- c. Pull the tie rod in the direction of arrow head to the point where a slight resistance is encountered. In this position, the tie rod does not pull on the governor spring.
- d. Turn in the torque spring set while lightly pulling the tie rod until the line mark on the control rack is aligned with the line mark on the pump body.
- e. With these line marks aligned, lock the torque spring set in position by tightening the special nut.
- f. Install the sealing cap over the torque spring set and stake the cap in position.

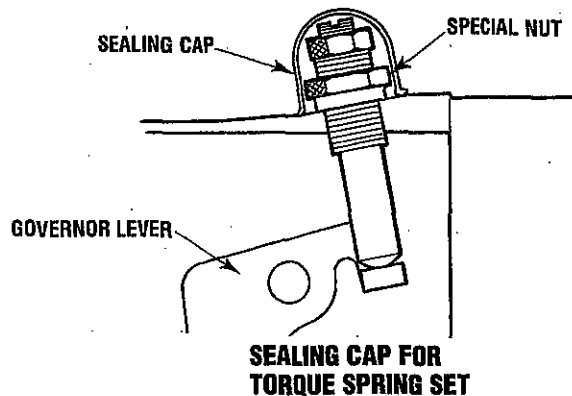
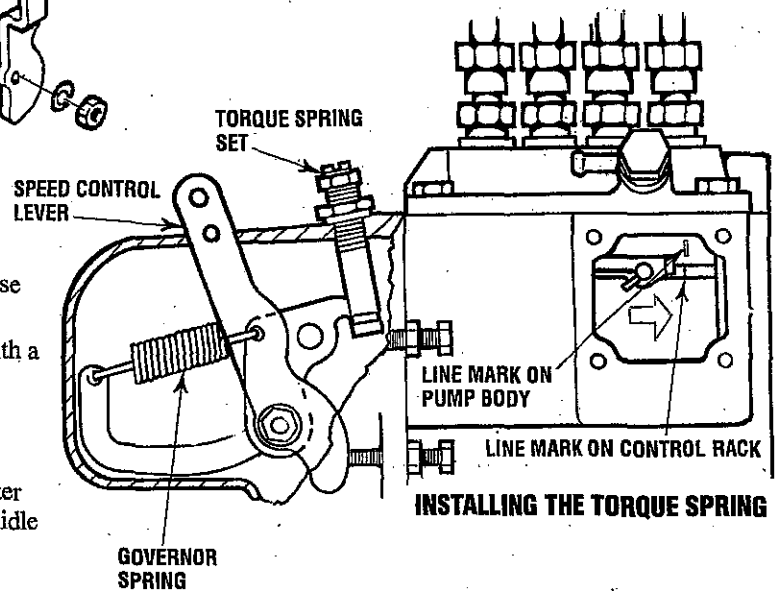

# FUEL INJECTION TIMING

## Preparation

- Close the fuel shut-off valve.
- Disconnect the No.1 fuel injection pipe from the cylinder head and injection pump.
- Remove No.1 delivery valve holder from the injection pump. Remove the delivery valve and spring from the holder. Restore the delivery valve holder only to the injection pump.
- Connect the fuel injection pipe to the injection pump.
- Hold the speed control lever in the low speed position. (Generator) remove the fuel shut-off solenoid.

## Inspection [fuel flow method]

- Open the fuel shut-off valve. Turn the key switch to the ON position and press preheat.

**NOTE:** Fuel will come from the injection pipe with high pressure when the starter switch key is turned to ON position if the engine is equipped with an electric fuel pump. Direct fuel flow into the container.

- Slowly turn the crankshaft clockwise, looking at the open end of the injection pipe. The instant fuel stops coming out is the fuel injection timing.

**NOTE:** Turn the crankshaft in reverse direction just a little and do step b again to verify the injection timing.

- The fuel injection timing is correct if the IT mark on the crankshaft pulley is aligned with the mark on the timing gear case when fuel stops from the injection pipe.

FUEL INJECTION TIMING: BTDC 17° (STANDARD)

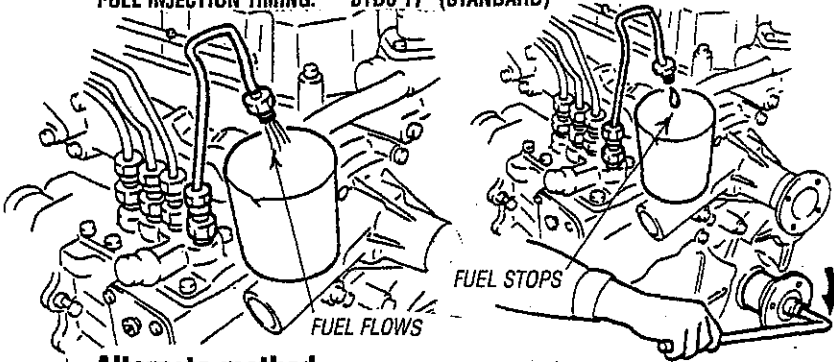

## Alternate method

In the fuel flow method, the delivery valve has to be removed. As a result, there is a good chance for dirt particles to get inside the fuel injection pump. In this alternate method, however, it is not necessary to remove the delivery valve.

- Disconnect No.1 fuel injection pipe at the fuel injection nozzle (cylinder head).
- Prime the fuel system.
- Slowly turn the crankshaft clockwise until fuel just swells at the free end of the injection pipe and, at that instant, check the position of the IT mark with respect to the mark on the gear case. This timing is approximately 1° retarded. Take this 1° retardation into account when making a shim adjustment.

## Adjustment

- If the fuel injection timing is incorrect, change the thickness of shims under the fuel injection pump. An increase or decrease of the shims by 0.1mm (0.004 in) will vary the timing by 1°.
- Increase the thickness of the shims to retard the timing or decrease it to advance the timing.

ADJUSTMENT RANGE: STANDARD  $\pm 1.5^\circ$

Four kinds of shims are available in thicknesses 0.2mm (0.0079 in), 0.3mm (0.0118 in), 0.4mm (0.0157 in) and 0.8mm (0.0315 in). These shims have no identification, measure the thickness of each shim with calipers before using it.

**CAUTION:** Apply sealant to both faces of each shim to prevent oil leaks.

- After the timing has been adjusted, make sure it is correct.
- Close the fuel filter valve and restore the delivery valve and injection pipe to the original state.

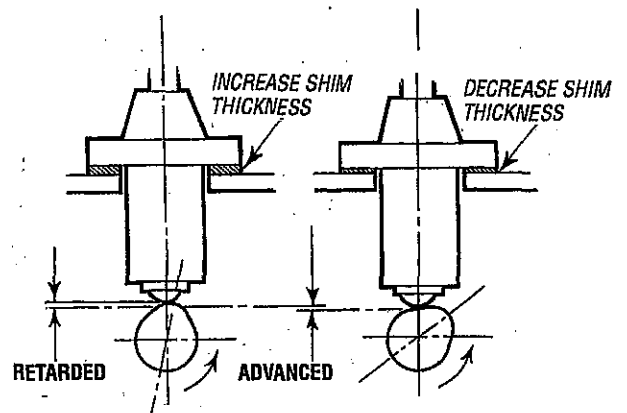
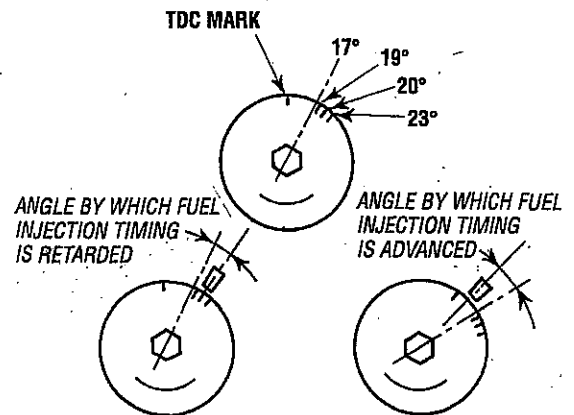

# FUEL INJECTORS

## REMOVING THE INJECTORS

**NOTE:** Injector must be serviced in a "clean room" environment.

1. Disconnect the high pressure lines from the injectors and loosen the lines at their attachment to the injection pump and move them out of the way of the injectors. Avoid bending the lines.
2. Remove the fuel return line in its entirety from the top of the injectors. Take care not to lose the sealing washers and banjo bolt that attaches the fuel return line to each injector.
3. Unscrew the injector from the cylinder head using a suitable deep socket.

**NOTE:** Clean the area around the base of the injector prior to lifting it out of the cylinder head to help prevent any rust or debris from falling down into the injector hole. If the injector will not lift out easily and is held in by carbon build up or the like, work the injector side to side with the aid of the socket wrench to free it and then lift it out.

4. The injector seats in the cylinder head on a copper sealing washer. This washer should be removed with the injector and replaced with a new washer when the injector is reinstalled.

**NOTE:** Greatest possible care should be taken in handling the nozzles as they are precisely machined. The nozzle and the needle valve are matched parts. Do not mix their original combinations. Disassemble and wash each nozzle assembly separately.

Carbon deposits on the nozzle body must be removed with a piece of hard wood. However, it would be advisable not to clean the surrounding area of the nozzle orifice to avoid possible damage to the orifice.

## INJECTION TESTING/ADJUSTMENT

1. Using the nozzle tester, check the spray pattern and injection starting pressure of nozzle and, if it exceeds the limit, adjust or replace the nozzle. When using nozzle tester, take the following precautions:

**CAUTION:** The spray injected from the nozzle is of such velocity that it may penetrate deeply into the skin of fingers and hands, destroying tissue. If it enters the bloodstream, it may cause blood poisoning.

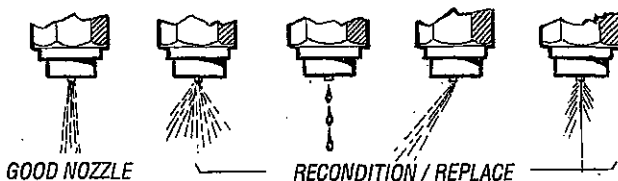

- a. If the diesel fuel of the nozzle tester is discolored, replace it. At the same time, clean or replace the fuel filter.
- b. Mount the nozzle and nozzle holder on the nozzle tester.
- c. Operate the hand lever of nozzle tester several times to bleed the air in the nozzle line, then move the hand lever at intervals of one stroke per second while reading the injection starting pressure.

**INJECTOR STARTING PRESSURE** 1991<sup>±</sup> psi (140<sup>±</sup> kgf-cm)

- d. If the fuel injection starting pressure is not within the specification, it can be adjusted by removing or adding shims in the injector body to achieve proper pressure.

**NOTE:** An increase or decrease of shim thickness by 0.004 in (0.1mm) will vary the injection pressure by 142 psi (10 kgf-cm). Ten shims are available in thickness from 1.25 mm to 170 mm (0.0492 in to 0.0669 in) in increments of 0.0020 in (0.05 mm).

- e. When replacing the shim, grip the retaining nut in a vise and remove the body with a wrench. Tighten the retaining nut to the specified torque.

**NOZZLE BODY TORQUE** 27 ± 1.8 lb-ft (3.75 ± 0.25 kgf-m)

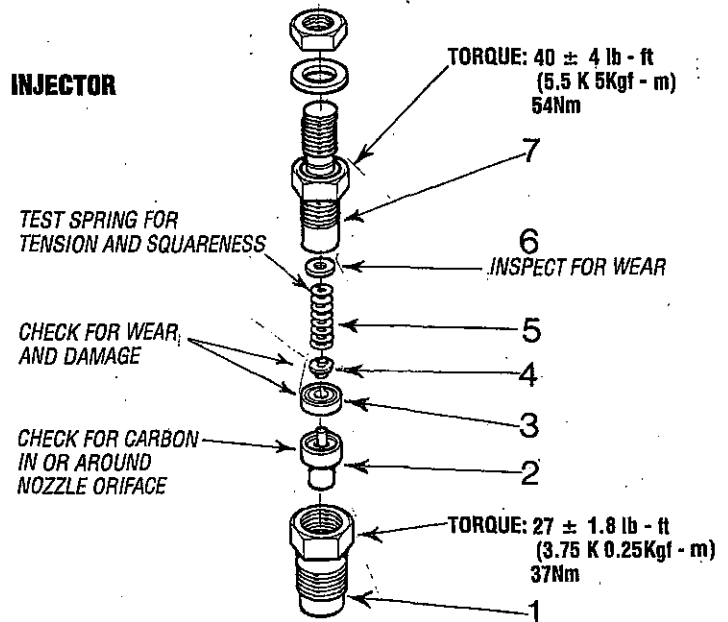

## DISASSEMBLY AND INSPECTION

1. Clamp the nozzle holder in a vise, remove the nozzle nut and disassemble the nozzle body, spring, and needle.
2. Clean the disassembled parts with clean diesel fuel.

## INSTALLING

1. Install in the reverse order of removal.

**NOTE:** The copper washers should not be reused. Replace with new washers.

2. Tighten the nozzle on the cylinder head to the specified torque.

**NOZZLE TORQUE** 40 ± 4 lb-ft (5.5 ± 0.5 kgf-m)

# GLOW PLUG TESTING

## GLOW PLUGS

To inspect the plug, remove the electrical terminal connections, then unscrew or unclamp each plug from the cylinder head. Thoroughly clean each plug's tip and threads with a soft brush and cleaning solution to remove all the carbon and oil deposits. While cleaning, examine the tip for wear and burn erosion; if it has eroded too much, replace the plug.

An accurate way to test glow plugs is with an ohmmeter. Touch one prod to the glow plug's wire connection, and the other to the body of the glow plug, as shown. A good glow plug will have a 1.0 - 1.5 ohm resistance. This method can be used with the plug in or out of the engine. You can also use a multimeter to test the power drain (8 - 9 amps per plug).

Re-install the plugs in the engine and test them again. The plugs should get very hot (at the terminal end) within 7 to 15 seconds. If the plugs don't heat up quickly, check for a short circuit. When reinstalling the glow plugs, use anti-seize compound on the threads.

**⚠ WARNING:** *These glow plugs will become very hot to the touch. Be careful not to burn your fingers when testing the plugs.*

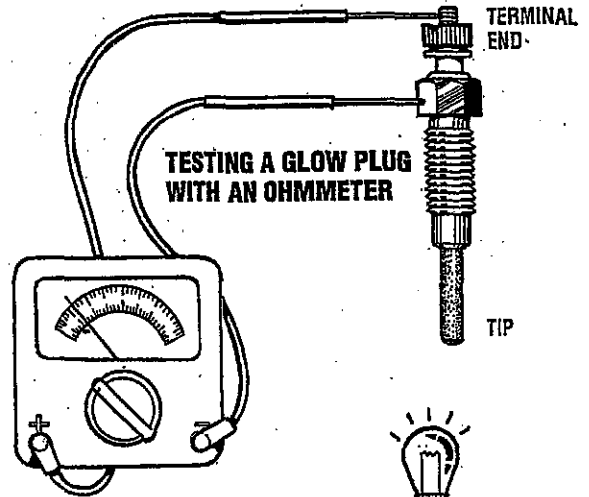

TESTING A GLOW PLUG USING A TEST LIGHT

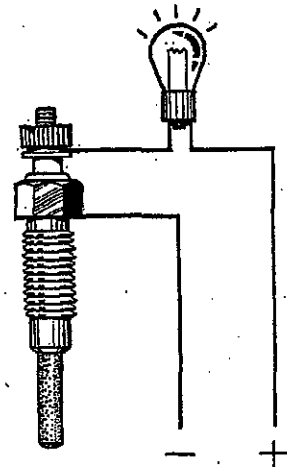

**⚠ WARNING:** *Do not keep a glow plug on for more than 30 seconds.*

GLOW PLUG TIGHTENING TORQUE . 7 - 11 ft-lb (1.0 - 1.5 m·kg)

# STARTER MOTOR

## DESCRIPTION

The starter can be roughly divided into the following sections:

- A motor section which generates a drive power.
- An overrunning clutch section which transmits an armature torque, preventing motor overrun after starting.
- A switch section (solenoid) which is operated when actuating the overrunning clutch through a lever and which supplies load current to the motor.

The starter is a new type, small, light-weight and is called a high-speed internal-reduction starter. The pinion shaft is separate from the motor shaft; the pinion slides only on the pinion shaft. A reduction gear is installed between the motor shaft and a pinion shaft. The pinion sliding part is not exposed outside the starter so that the pinion may slide smoothly without becoming fouled with dust and grease. The motor shaft is supported at both ends on ball bearings. The lever mechanism, switch and overrunning clutch inner circuit are identical to conventional ones.

## ADJUSTMENT AND REPAIR

If any abnormality is found by the following tests, the starter should be disassembled and repaired.

### Pinion Gap Inspection

1. Connect a battery (12V) between the starter terminal S and the starter body, and the pinion drive should rotate out and stop.

**CAUTION:** Never apply battery voltage for over 10 seconds continuously.

2. Lightly push the pinion back and measure the return stroke (called pinion gap).
3. If the pinion gap is not within the standard range, 0.0197 - 0.0788in (0.5 to 2.0mm), adjust it by increasing or decreasing the number of shims on the solenoid. The gap is decreased as the number of shims increases.

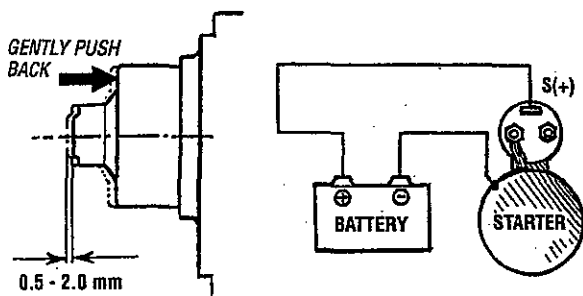

PINION GAP

## No-Load Test

1. Connect the ammeter, voltmeter, and battery to the starter as illustrated.
2. When the switch is closed, the pinion must protrude and the starter must run smoothly (at 3000 rpm or more). If the current or starter speed is out of specification, disassemble the starter and repair it.

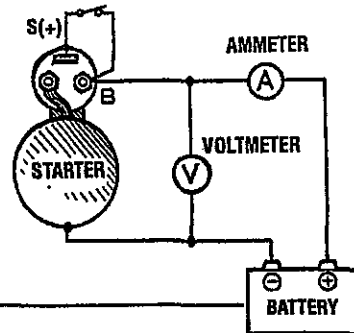

**CAUTION:** Use thick wires as much as possible and tighten every terminal securely. This is a solenoid shift-type starter which makes a rotating sound louder than that of a direct-drive type starter. When detecting starter rotation at the pinion tip, be careful not to come in contact with the pinion gear when it protrudes.

## SOLENOID

Perform the following tests. If any test result is not satisfactory, replace the solenoid assembly.

1. Inspect the solenoid for continuity between terminals (+) and (-) and between terminals S and the body and M and the body. There should be no continuity found between terminals S and M. Continuity will be found between terminals S and the body and terminal M and the body.

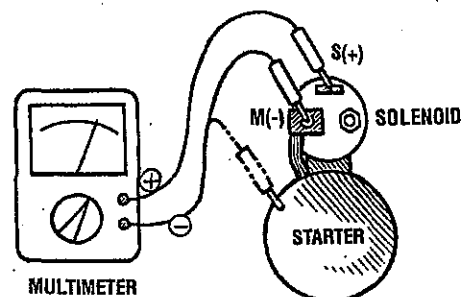

**NOTE:** Disconnect the wire from terminal M.

2. Connect a battery to the solenoid's terminal S for (+) and M for (-). Have a switch in the + lead and close it. The pinion drive should extend fully out.

**CAUTION:** Do not apply battery current for more than 10 seconds when testing the solenoid.



# STARTER MOTOR

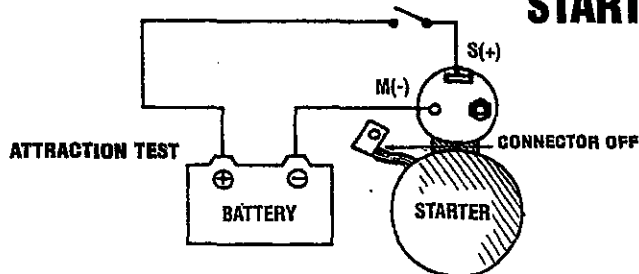

3. *Holding test.* With a battery connected to the solenoid terminal S (+) and to the starter body, manually pull out the pinion fully. The pinion must remain at that position even when released from holding with your hand.

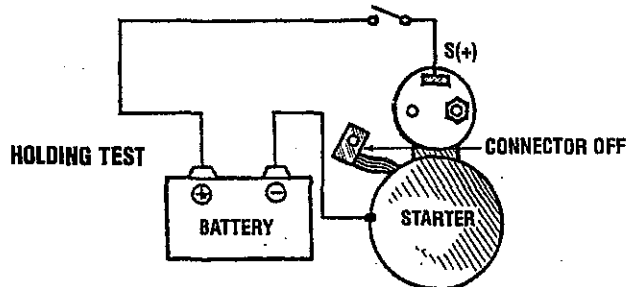

4. *Return test:* With a battery connected to the solenoid terminal M (-) and to the starter body, manually pull out the pinion fully. The pinion must return to its original position when released from holding by hand.

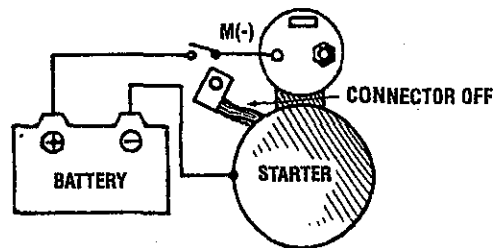

## STARTER ASSEMBLY

1. Disconnect the wire from the solenoid terminal M (-).
2. Loosen the two screws fastening the solenoid. Remove the solenoid assembly.
3. Remove the two long through bolts and two screws fastening the brush holder. Remove the rear bracket.
4. With the brushes pulled away from the armature, remove the yoke and brush holder assembly. Then pull the armature out.
5. Remove the cover, pry the snap ring out, and remove the washer.
6. Unscrew the bolts and remove the center bracket. At the same time, the washers for the pinion shaft end play adjustment will come off.

7. Pull out the reduction gear lever and lever spring from the front bracket.
8. On the pinion side, pry the snap ring out, and pull out the pinion and pinion shaft.
9. At each end of the armature, remove the ball bearing with a bearing puller. It is impossible to replace the ball bearing press-fitted in the front bracket. If that bearing has worn off, replace the front bracket assembly.

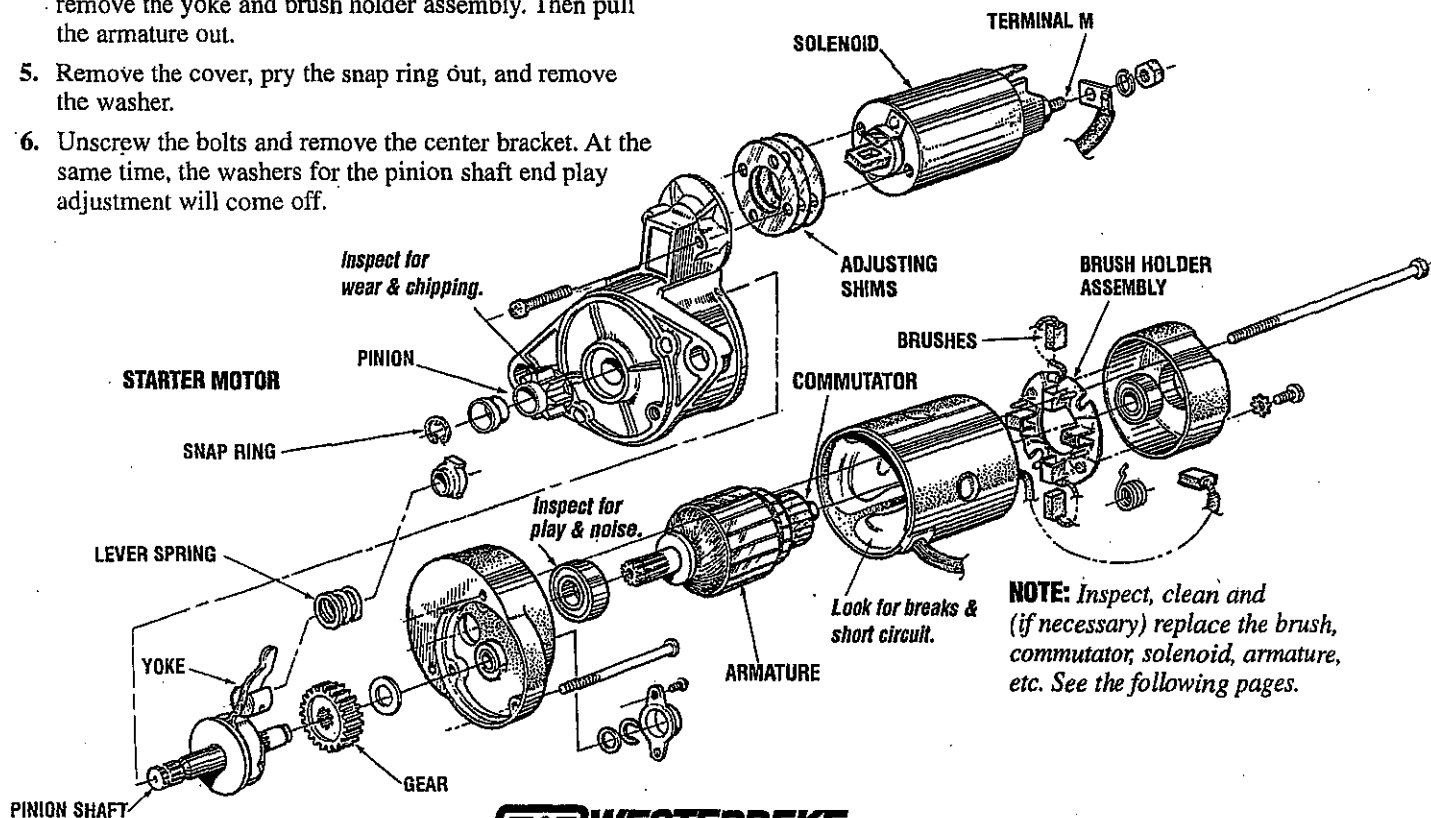

**NOTE:** Inspect, clean and (if necessary) replace the brush, commutator, solenoid, armature, etc. See the following pages.

# STARTER MOTOR

## STARTER INSPECTION

### Solenoid

Inspect the solenoid for continuity between terminals S and M and between terminals S and body. No continuity should be found between S and M. Continuity should be found between S and the body and M and the body.

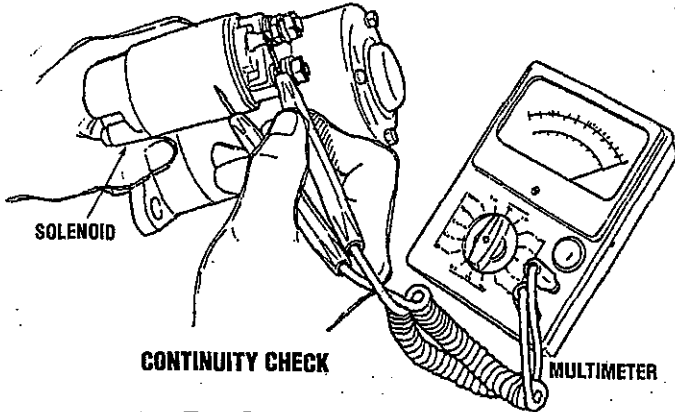

### Inspecting The Armature

1. Check the armature with a growler tester. If it is short circuited, replace the armature. Also check for insulation between the commutator and its shaft. If poorly insulated, replace the armature.

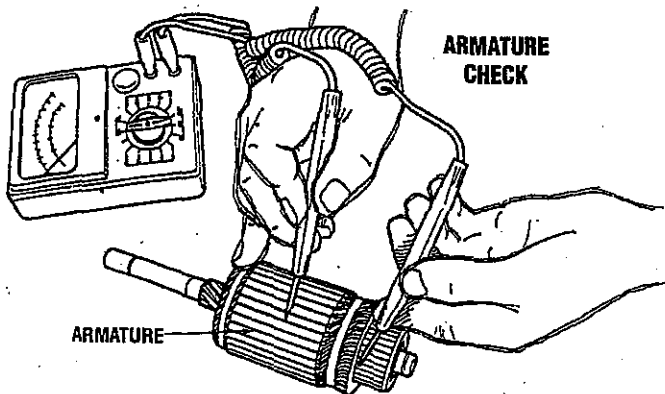

2. Measure the commutator O.D. and the depth of undercut. Repair or replace it if the service limit is exceeded. Also, check the commutator outside surface for dirtiness and roughness. If rough, polish the commutator with fine crocus cloth.

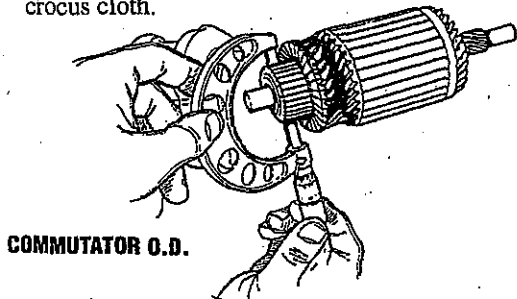

COMMUTATOR OUTSIDE DIAMETER	
STANDARD	1.26 in (32 mm)
LIMIT	1.22 in (31 mm)

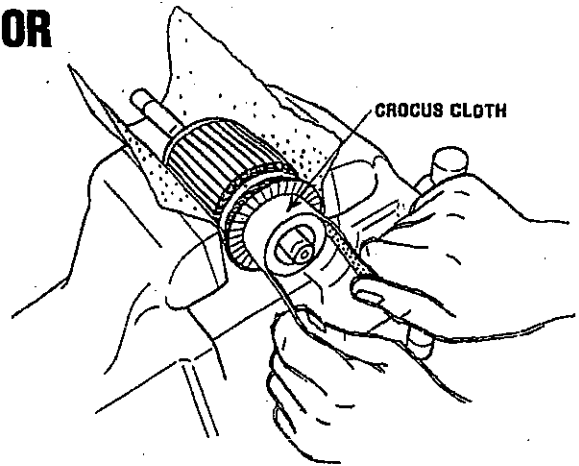

### Brush and Brush Holder Inspection

1. Check the brushes. If worn out beyond the service limit, replace the brushes.

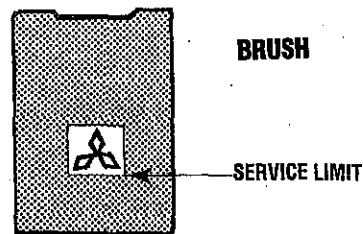

2. Check the brush spring tension. A weak or defective spring will cause excessive brush wear; replace the springs if suspect.

BRUSH HEIGHT	
STANDARD	6.6 lbf (3.0 kgf)
LIMIT	4.0 lbf (1.8 kgf)

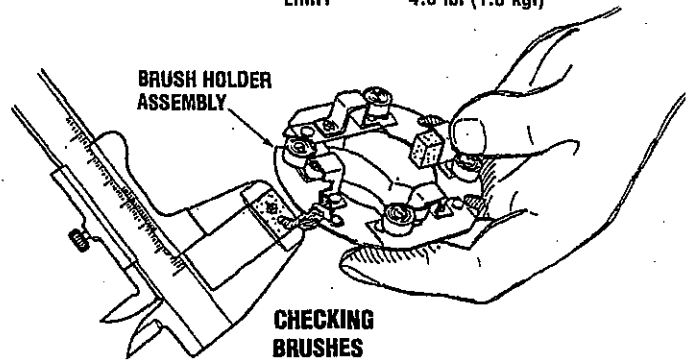

3. Check for insulation between the positive brush holder and holder base. If poorly insulated, replace the holder assembly. Also check the brush holders for proper staking.

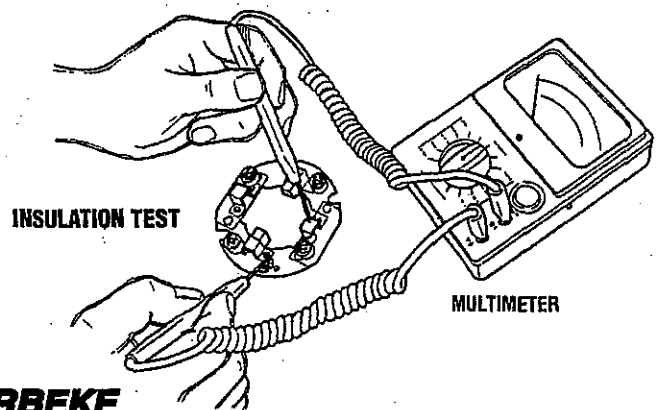

# STARTER MOTOR

## COMMUTATOR MICA UNDERCUT

Measure the undercut of mica insulation between the adjacent segments. If undercut exceeds the limit, recondition the mica or replace the armature.

STANDARD 0.020 in (0.5 mm)  
LIMIT 0.008 in (0.2 mm)

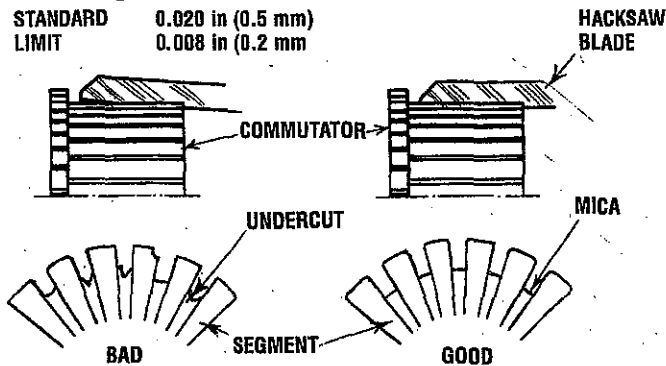

## Field Coil Inspection

1. Check for insulation between one end (brush) of the coil and yoke.
2. Check for continuity between both ends (brushes) of the coil.
3. Check the poles and coil for tightness.

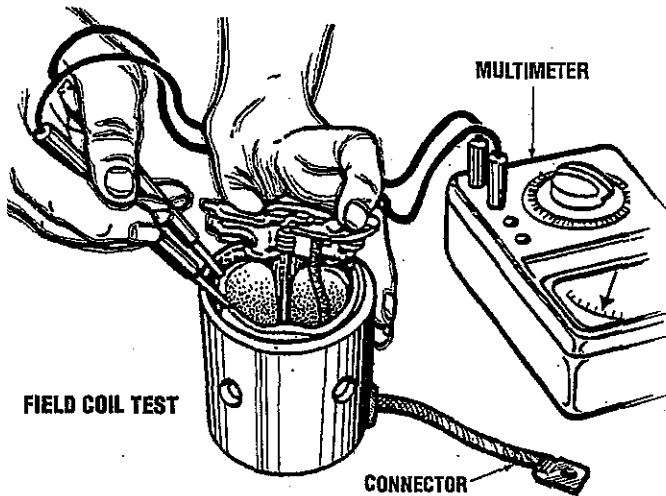

## STARTER ADJUSTMENT AND REASSEMBLY

**CAUTION:** Before installing, thoroughly clean the starter flange and mounting surfaces, remove all oil, old paint, and rust. Starter performance largely depends on the quality of the wiring. Use wire of sufficient size and grade between the battery and starter and fully tighten to the terminal.

Reassemble the starter assembly in the reverse order of disassembly, making sure of the following:

1. **Pinion shaft end play adjustment.** Set the end play (thrust gap) to between 0.5 to 2mm by inserting an adjusting washer between the center bracket and the reduction gear.
  - a. Fit the pinion shaft, reduction gear washer and snap ring to the center bracket.
  - b. Measure end play by moving the pinion shaft in the axial direction. If the end play exceeds 0.5mm, increase the number of adjusting washers inserted.

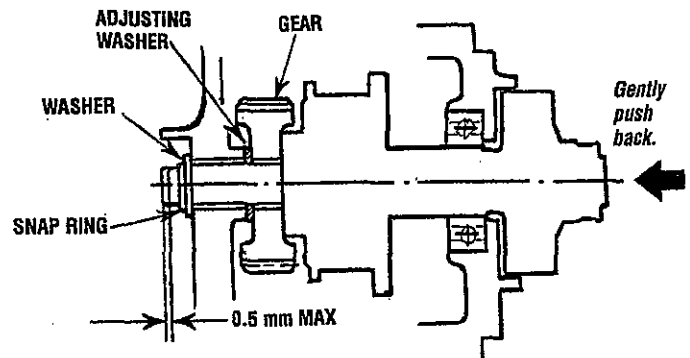

2. **Greasing.** Whenever the starter has been overhauled, apply grease to the following parts:
  - a. Armature shaft gear and reduction gear.
  - b. All bearings.
  - c. Bearing shaft washers and snap rings.
  - d. Bearing sleeves.
  - e. Pinion.
  - f. Sliding portion of lever.

**CAUTION:** Never smear the starter fitting surface, terminals, brushes, or commutator with grease.

3. After reassembly, check by conducting a no-load test again.

# RAW WATER PUMP (PN.33636)

## Disassembly

The pump, as removed from the engine, will have hose attachment nipples threaded into its inlet and outlet ports. They may be left in place or removed if they interfere with the pump disassembly. Note the port location and positioning if removed.

1. Remove the six cover plate screws, cover plate, and the cover plate gasket.  
**NOTE:** Replacement of the cover plate gasket is recommended; however, if you are going to reuse it, keep the gasket submerged in water until the pump is reassembled. If it's allowed to dry, the gasket will shrink and not be reusable.
2. Remove the impeller with its drive screw from the pump housing.
3. Remove the screw and sealing washer and remove the cam from the pump housing.
4. Remove the retaining ring.
5. Support the pump housing, at the mounting flange end, on an arbor press, and with a drift, press out the shaft and bearings from the pump housing.
6. With the pump housing supported, push the seals out of the pump housing. Push the impeller side seal out the impeller side, then lift the spacer out. Then push the bearing side seal out the bearing side.
7. Supporting the bearing's inner race, push the shaft out of the bearings.

## Inspection

Inspect all parts and replace those showing wear or corrosion.

## Reassembly

1. Install the seals and spacer in the pump housing. Push the impeller side seal into the housing. Rotate the pump and install the spacer against the seal face. Push the bearing side seal into the housing from the bearing side.

**NOTE:** The seals' flat surfaces that have printing and numbers face toward each other.

2. Install the shaft into the bearings. Support the bearings at their center races. Push the shaft into the bearings, pushing at the impeller drive slot end using the base of the drive slot. Push the shaft through both of the bearings, flush against each other so the flat-sided end of the shaft extends beyond the second bearing center race  $19/32$  in ( $15\text{ mm}$ )  $\pm 1/32$  in ( $.5\text{ mm}$ ).
3. Support the pump housing at the impeller side. Apply a small amount of petroleum jelly to the seal's inner lips and to the impeller shaft. Carefully install the shaft, rotating it through the seals until the bearings contact the housing from the bearing end. Use a pushing tool that will push this shaft and the bearing assembly into the pump housing by applying pressure against the outer bearing race. Push the assembly into the housing until the bearings seat fully in the housing. Install the retaining ring.  
**NOTE:** Use a small amount of Permatex #1 on the inner cam surface and screw threads. Remove any excess from the impeller housing.
5. Apply a light film of silicone or petroleum jelly to the inner surface of the housing for the impeller.  
**NOTE:** Coat only the surface, do not over-apply. Install the impeller with the drive screw. Push the assembly into the housing with the drive screw mating in the slot of the drive shaft.
6. Install the cover gasket and cover, and secure them with the six cover screws.
7. Reposition and tighten the hose nipples. Assemble the pump to the engine, and attach the hoses.

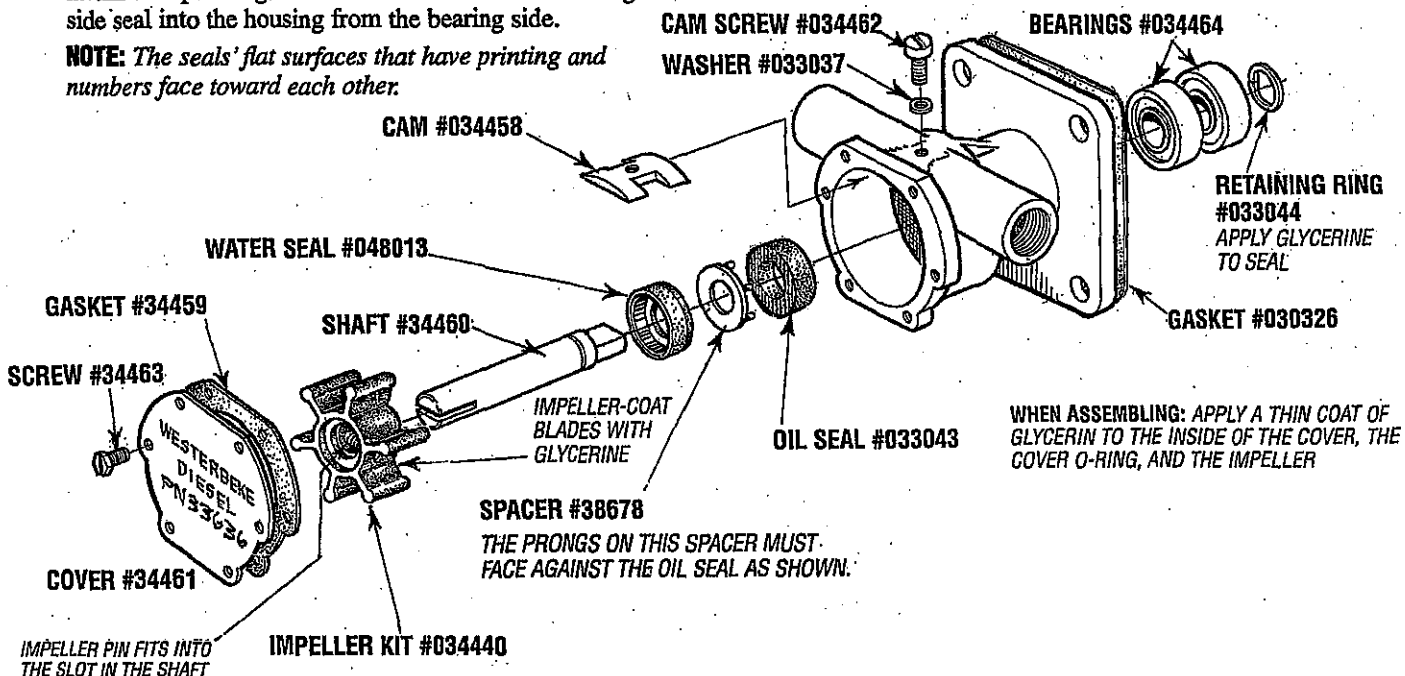

# RAW WATER PUMP (PN. 48080)

## Disassembly

**NOTE:** Refer to the following page for parts list and exploded view.

The pump, as removed from the engine, will have hose attachment nipples threaded into its inlet and outlet ports. They may be left in place or removed if they interfere with the pump disassembly. Note the port location and positioning if removed.

1. Remove the six cover plate screws, cover plate, and the cover plate gasket.

**NOTE:** Replacement of the cover plate gasket is recommended; however, if you are going to reuse it, keep the gasket submerged in water until the pump is reassembled. If it's allowed to dry, the gasket will shrink and not be reusable.

2. Remove the impeller with its drive screw from the pump housing.
3. Remove the screw and sealing washer and remove the cam from the pump housing.
4. Remove the wear plate and leave the pin in place.
5. Remove the front circlip, washer and water seal.
6. Remove the rear circlip
7. Support the pump housing at the mounting flange end. Using an arbor press and with a suitable drift, carefully press the shaft with bearings from the pump housing.
8. The slinger and oil seal will remain in the housing. Remove the oil seal and slinger.
9. Support the bearings inner race and push the shaft out of the bearings.

## Inspection

Inspect all parts and replace those showing wear, cracks or corrosion.

## Reassembly

1. Support the bearings inner race. Press the shaft into the bearings so that the drive end of the shaft extends beyond the second bearings inner race by  $19/32$ " (15mm)  $1/32$ " (.5mm)

**NOTE:** The seals' flat surfaces that have printing and numbers face toward each other.

2. Install the oil seal in the pump housing.
3. Support the pump. Lubricate the shaft and slide it thru the oil seal and press the bearings with shaft into the housing so that the outer bearing just clears the rear circlip retaining groove.
4. Install the rear circlip and press the shaft with bearings so that the outer bearing seats on the rear circlip.
5. Lubricate the slinger and slide it onto the shaft so that it is visible midway through the slotted openings of the pump housing.
6. Lubricate the inner half of the water seal, slide it over the shaft and seat it in the pump housing. Install the outer half, washer and front clip to hold the seal in place.
7. Install the wear plate and cam. Apply sealant (Permatex #1) to the cam screw threads and inner cam surfaces. Remove excess.
8. Lubricate and install the impeller. Blade positioning does not matter.  
**NOTE:** Use the lubricant that comes with the impeller. Coat only the surface. Do not over-apply.
9. Install the O-ring and cover plate.

Refer to #48080 parts list on next page.

# RAW WATER PUMP (PN. 48080) PARTS LIST

KEY NO.	PART NUMBER AND PART NAME	QUANTITY
1	48080 RAW WATER PUMP	1
2	49172 SHAFT	1
3	49170 IMPELLER COVER	1
4	48500 IMPELLER KIT (O-RING & GLYCERIN)	1
5	34458 CAM	1
6	49171 WEAR PLATE	1
7	302575 DOWEL	1
8	48253 SPRING SEAL WASHER	1
9	34463 IMPELLER COVER SCREW	6
10	48359 IMPELLER COVER O-RING	1
11	33041 O-RING	1
12	33037 CAM WASHER	1
13	46662 CAM SCREW	1
14	48254 SPRING SEAL	1
15	49169 LIP SEAL	1
16	34464 BALL BEARING	2
17	33045 RETAINING INTERNAL RING	1
18	33044 RETAINING EXTERNAL RING	1
	49000 PUMP REPAIR KIT; (SEE NOTE)	1
	37431 PUMP KIT (MOUNTING GASKET & FITTINGS)	1

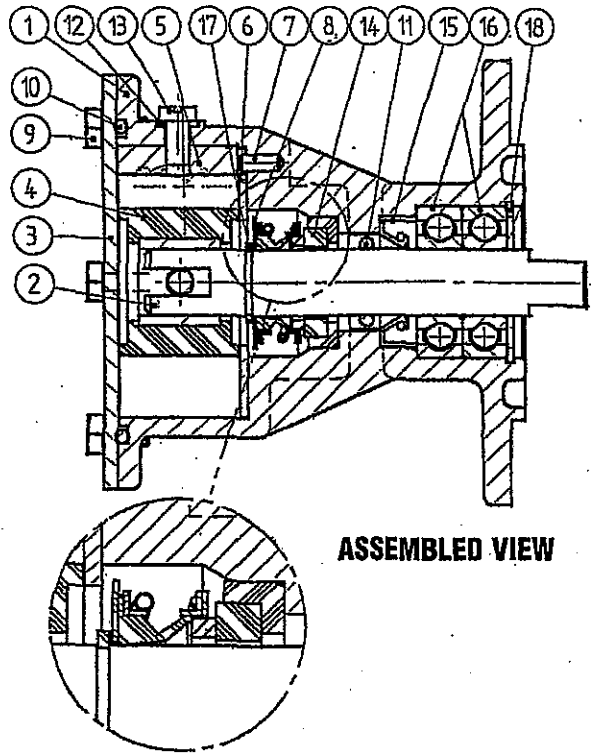

**NOTE**

THE PUMP REPAIR KIT (49000) INCLUDES ALL THE LISTED COMPONENTS EXCEPT ITEMS 1 AND 7. THE KIT ALSO INCLUDES A PUMP MOUNTING GASKET.

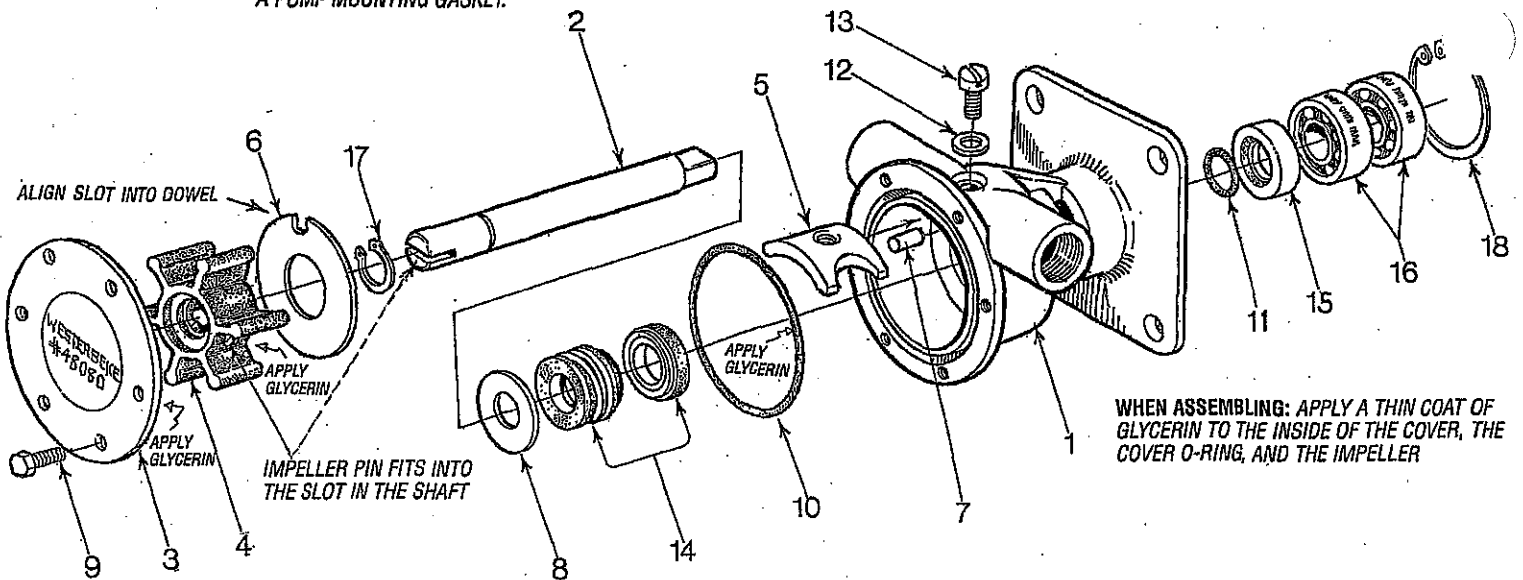

# ENGINE ADJUSTMENTS

## VALVE CLEARANCE ADJUSTMENT

Make the following adjustments when the engine is cold.

- Remove the cylinder head cover.
- Slightly loosen the cylinder head bolts and retighten them to the specified torque in the number sequence shown below.

TIGHTENING TORQUE  $65 \pm 4$  lb-ft ( $88 \pm 5$  Nm)

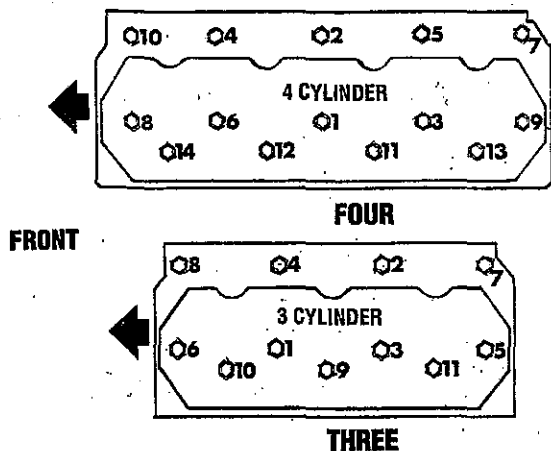

- Find top dead center compression position for No. 1 piston by using the procedure that follows:
- Turn the crankshaft until TDC mark on the crankshaft pulley is aligned with the mark on the timing gear case.

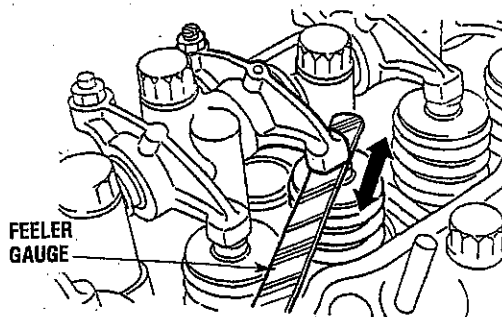
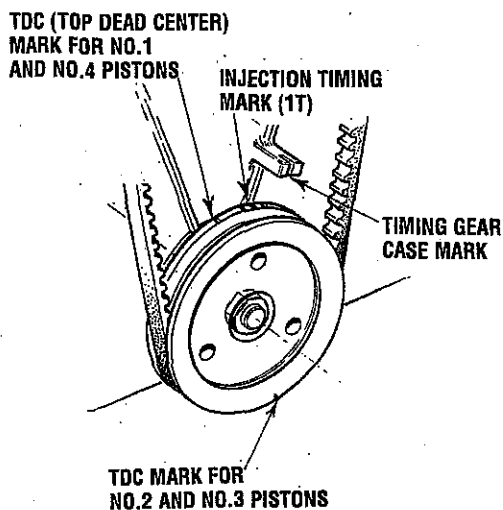

- With No. 1 piston at top dead center on the compression stroke, the rocker arms will not be moved when the crankshaft is turned approximately  $20^\circ$  in both directions.
- If the rocker arms move, No. 1 piston is at top dead center on the intake or exhaust stroke. In such a case, turn the crankshaft  $360^\circ$  in the direction of engine rotation again. No. 1 piston is now at top dead center on the compression stroke.
- Loosen the locknut for the adjusting screw. With a feeler gauge inserted between the rocker arm and valve cap, adjust the valve clearance by turning the adjusting screw. Make certain to adjust all the valves.

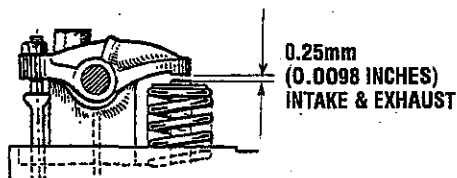

- Hold the adjusting screw and tighten the locknut.
- After the valve clearance on the valves for No. 1 cylinder has been adjusted, turn the crankshaft  $180^\circ$  in the direction of engine rotation and adjust the valve clearance on the valves for the remainder of the cylinders in firing order (injection sequence).

### INJECTION SEQUENCE:

- 3 1-3-2  $240^\circ$  CRANKSHAFT ROTATION  
4 1-3-4-2  $180^\circ$  CRANKSHAFT ROTATION

- After the valve clearance on the valves for all the cylinders have been adjusted, turn the crankshaft two or three times and make certain the clearance is correct.
- Install the cylinder head cover.

HEAD COVER BOLT TORQUE  $2 - 3$  ft-lb (0.3 - 0.45 m-kg)

# ENGINE ADJUSTMENTS

## TESTING ENGINE COMPRESSION

Make certain the oil level (dipstick) is at the correct level and the air intake filter is clean. The battery and starter motor must also be in good condition.

- Warm the engine to normal operating temperature.
- Move the control lever to a position for shutting off the fuel. (Disconnect the wires if a fuel shutdown solenoid is used).
- Remove all the glow plugs from the engine and install the compression gauge/adaptor combination to the cylinder on which the compression is to be measured.
- Close the raw water seacock (thru-hull).
- Crank the engine and allow the gauge to reach a maximum reading, then record that reading.
- Repeat this process for each cylinder.

**COMPRESSION PRESSURE** 427 psi (30 kgf/cm<sup>2</sup>) at 290 rpm.

**MAXIMUM PERMISSIBLE DIFFERENCE BETWEEN CYLINDERS**  
42.7 psi (3 kgf/cm<sup>2</sup>)

**NOTE:** If the readings are below the limit, the engine needs repair.

- Re-install the glow plugs (use anti-seize compound on the threads) and reset the fuel shut-off to the run position.
- Open the raw water seacock (thru-hull).

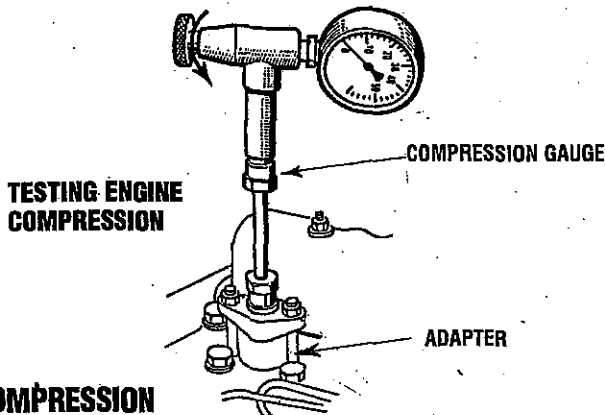

## LOW COMPRESSION

When low compression is found, determine the cause by applying a small amount of oil in the cylinder thru the glow plug hole. Allow the oil to settle.

Install the pressure gauge and repeat the above test. If the compression reading rises dramatically, the fault is with the rings. If the compression valve does not rise, the problem is with the valves.

A slight rise in compression would indicate a problem with both the rings and the valves.

## AIR INTAKE FILTER/SILENCER

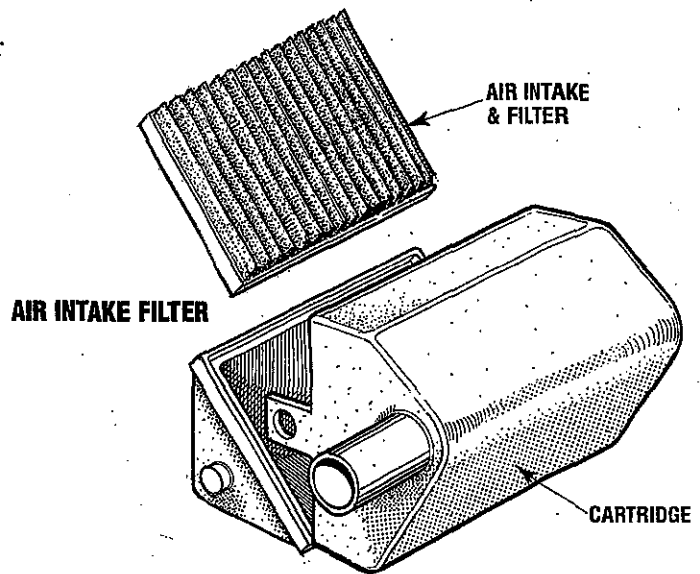

The filter cartridge should be cleaned every 100 operating hours. Tap the cartridge on a flat surface to dislodge loose dirt or clean with compressed air. If the filter cartridge is badly contaminated or oily, replace it.

**NOTE:** Failure to properly maintain the air intake filter can result in engine oil consumption and filter deterioration and ingestion into the engine.



# ENGINE ADJUSTMENTS

## GENERATOR FREQUENCY ADJUSTMENT (HERTZ)

Once the diesel generator set has been placed in operation, there may be adjustments required for engine speed (Hertz) during the engine's break-in period (first 50 hours) or after this period. A no-load voltage adjustment may also be required in conjunction with the engine's speed adjustment. These are not warrantable adjustments as they relate to normal break-in and maintenance.

Frequency is a direct result of engine/generator speed, as indicated by the following:

**When the generator is run at 1800 rpm, the AC voltage output frequency is 60 Hertz.**

**When the generator is run at 1500 rpm, the AC voltage output frequency is 50 Hertz.**

Therefore to change the generator's frequency, the engine speed *must* be changed. To accomplish the frequency change, perform the following:

1. With the engine stopped, connect the AC output leads to the AC terminal block in accordance with the AC voltage connections diagram specified for your generator set, and change the Hertz circuit connection to the capacitor. These connections are shown in the GENERATOR section of this manual.

**⚠ WARNING:** Before starting the engine make certain that everyone is clear of moving parts! Keep away from pulleys and belts during test procedures.

2. Start the engine and adjust the engine's speed to obtain the frequency corresponding to the voltage selected by adjusting the stop bolts and positioning the throttle arm against these stop bolts to either increase or decrease engine no-load speed to adjust the Hertz produced.
3. To arrive at the appropriate frequency, either monitor the speed of the engine/generator with a tachometer, or monitor the frequency with a frequency meter, the latter method being the more precise of the two.

## FUEL RUN SOLENOID

The fuel run solenoid is mounted in a threaded hole on the engine's block just aft of and below the engine's fuel injection pump. Proceed as follows when installing a replacement or new fuel run solenoid.

1. Visual access to the fuel injection pump's fuel rack is needed. To obtain this, remove the small square side cover and gasket just below the fuel injection pump.
2. Thread the locknut onto the solenoid and then apply a small amount of Teflon sealant to the threads on the solenoid.
3. Thread the solenoid into the hole on the engine and observe the solenoid plunger through the cover opening. Allow the plunger to contact the fuel rack and move fully into the injection pump. Do not thread further so as to push the plunger into the solenoid.
4. Back the solenoid out 1/4 - 1/2 of a turn and secure it in position with the locknut.  
**LOCKNUT TORQUE VALUE 28.9 - 36.2 ft-lb (4.0 - 5.0 m-kg)**
5. Properly connect the three electrical leads from the solenoid. Two of the connections plug into the engine harness and the third grounds to the engine block at an adjacent inboard threaded hole with an 8mm bolt.
6. Reassemble the cover and gasket and test run the unit. Make certain that the unit stops when the solenoid is de-energized.

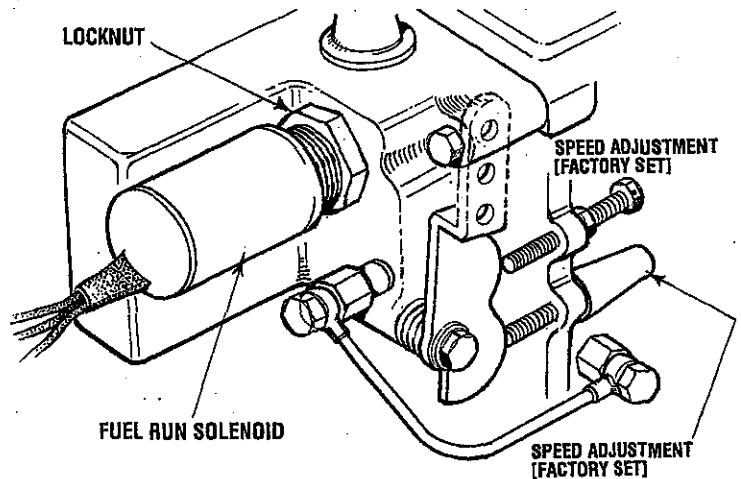

# ENGINE ADJUSTMENTS

## OIL PRESSURE

The engine's oil pressure, during operation, is indicated by the oil pressure gauge on the instrument panel. During normal operation, the oil pressure will range between 40 and 60 psi (2.8 and 4.2 kg/cm<sup>2</sup>).

**NOTE:** A newly started, cold engine can have an oil pressure reading up to 60 psi (4.2 kg/cm<sup>2</sup>). A warmed engine can have an oil pressure reading as low as 35 psi (2.5 kg/cm<sup>2</sup>). These readings will vary depending upon the temperature of the engine and the rpms.

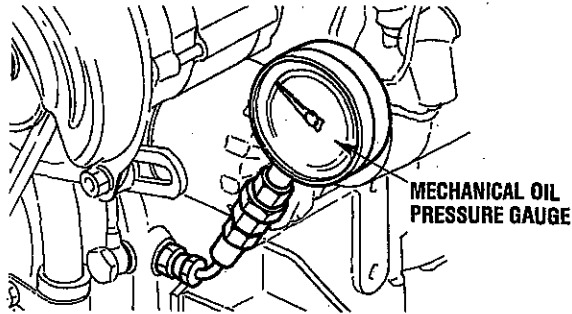

## OIL PRESSURE [GENERATOR]

Oil pressure at 1800 (or 1500) rpm should maintain a reading of 50 psi.

## TESTING OIL PRESSURE

To test the oil pressure, remove the oil pressure sender, then install a mechanical oil pressure gauge in its place. After warming up the engine, set the engine speed at 1800 rpm and read the oil pressure gauge.

**OIL PRESSURE** 50 psi at 1800 rpm.  
**SENDER AND SWITCH TORQUE** 9 - 13 ft-lb (1.2 - 1.8 m - kg).

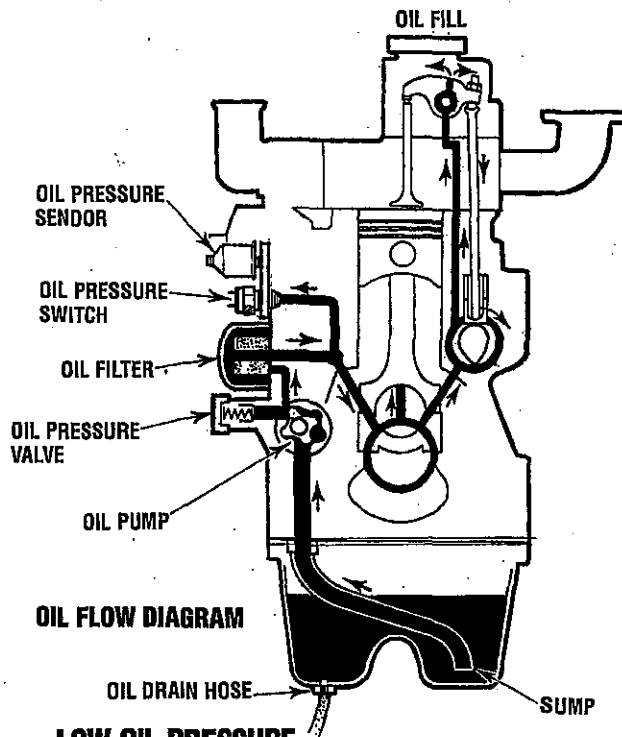

## LOW OIL PRESSURE

The specified safe minimum oil pressure is 4.3 + 1.4 psi (0.3 + 0.1 kg/cm<sup>2</sup>). A gradual loss of oil pressure usually indicates a worn bearings. For additional information on low oil pressure readings, see the *ENGINE TROUBLESHOOTING* chart.

## OIL PRESSURE RELIEF VALVE

An oil pressure relief valve is located on the engine block just below the injection pump. This valve opens at approximately 50 psi [343 kpa] and maintains that pressure.

# ENGINE ADJUSTMENTS

## ADJUSTING THE IDLE SPEED

- Loosen the locknut on the idle adjustment bolt on the fuel injection pump.
- Adjust the idle adjustment bolt so that the throttle control lever will hold the engine speed at a smooth/stable idle. Reference the RPM Chart below
- Tighten the locknut.
- Race the engine several times to ensure the idle speed remains as set.

**NOTE:** Should the engine rpm be in question, verify the tachometer readings as shown at the instrument panel with a mechanical or strobe-type tachometer at the engine crankshaft.

## RECOMMENDED RPM RANGE

Model	Idle RPM	Cruise RPM	Max. RPM
44A/FOUR	800-1000	2500-3000	3500-3600
44B/FOUR	800-1000	2000-2500	2900-3000
44C/FOUR	800-1000	2000-2500	2900-3000
35C/THREE	1000-1200	2500-3000	3500-3600
35D/THREE	1000-1200	2000-2500	2900-3000
35E/THREE	1000-1200	2000-2500	2900-3000

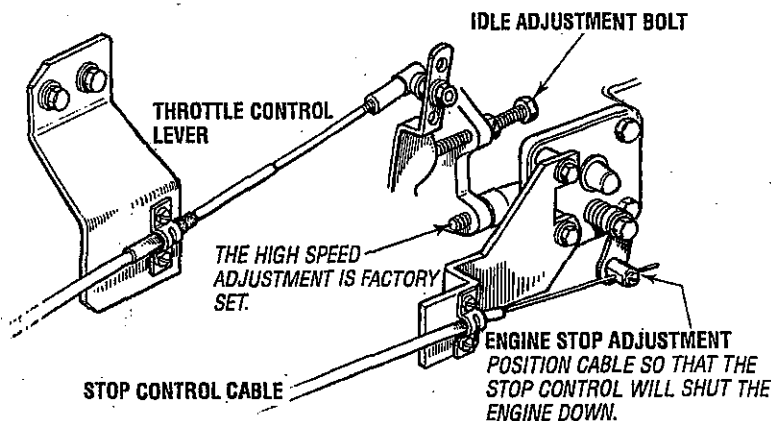

## Fuel Shutoff Solenoid [Optional]

The optional fuel shutoff solenoid allows the engine to be shut down using the instrument panel key switch. The solenoid has been factory set and does not require adjustment. Refer to the assembly procedure of the fuel shutoff solenoid for the proper setting and clearance of the plunger. See *FUEL SHUTOFF SOLENOID INSTALLATION*.

## Drive Belt Adjustment

Proper inspection, service and maintenance of the drive belts is important for the efficient operation of your engine.

Drive belts must be properly tensioned. Loose drive belts will not provide proper alternator charging and will eventually damage the alternator. Drive belts that are too tight will pull the alternator out of alignment and/or cause the alternator to wear out prematurely. Excessive drive belt tension can also cause rapid wear of the belt and reduce the service life of the coolant pump's bearing. A slack belt or the presence of oil on the belt can cause belt slipping, resulting in high operating temperatures and tachometer variations.

The drive belt is properly adjusted if the belt can be deflected no less than 3/8 inch (10mm) and no more than 1/2 inch (12mm) as the belt is depressed with the thumb at the midpoint between the two pulleys on the longest span of the belt. A spare belt or belts should always be carried on board.

**WARNING:** Never attempt to check or adjust the drive belt's tension while the engine is in operation.

## Adjusting Belt Tension

- Loosen the alternator adjusting strap bolt and the base mounting bolt.
- With the belt loose, inspect for wear, cracks and frayed edges.
- Pivot the alternator on the base mounting bolt to the left or right as required, to loosen or tighten.
- Tighten the base mounting bolt and the adjusting strap bolt.
- Run the engine for about 5 minutes, then shut down and recheck the belt tensions.

# SERVICE DATA - STANDARDS AND LIMITS

Component	Standard mm (Inches)	Repair Limit mm (inches)
<b>ENGINE COMPONENTS</b>		
Compression pressure.....	427 psi at 280 rpm (30.0 kg/cm <sup>2</sup> ) 2942 kPa	384 psi (27.0 kg/cm <sup>2</sup> ) 2648 kPa
Maximum permissible difference between average compression pressure of all cylinders	42.7 psi (3.0kg/cm <sup>2</sup> ) 294 kPa	
Injection timing at BTDC.....	17°	
Rocker arm bore for shaft.....	18.910 - 18.930 (0.74449 - 0.74527)	
Rocker arm shaft O.D.....	18.880 - 18.898 (0.74331 - 0.7440)	
Clearance between rocker arm and shaft (oil clearance).....	0.012 - 0.050 0.00047 - 0.00197	0.200 (0.00787)
Valve stem O.D.....	0.260 (6.6)	
Height of valve guide.....	0.39 (10)	
Valve clearance.....	0.25 (0.0098)	
Stem to guide clearance		
Intake.....	0.02 - 0.05 (0.008 - 0.0020)	0.10 (0.0039)
Exhaust.....	0.05 - 0.085 (0.0020 - 0.00335)	0.15 (0.0059)
Valve margin.....	1.0 (0.039)	0.5 (0.020) (valve lip thickness)
Valve sinkage.....	0.5 ± 0.25 (0.020 ± 0.0098)	1.5 (0.059)
Valve seat		
Angle.....	45°	
Width.....	1.3 - 1.8 (0.051 - 0.071)	2.5 (0.098)
Valve spring		
Free length.....	47 (1.85)	46 (1.81)
Length under test force.....	39.1 (1.54) 30.5 (1.20)	
Test force 39.1 (1.54).....	13.9 ± 0.7 30.6 ± 1.5 136 ± 7	-15%
Test force 30.5 (1.20).....	29 ± 2 64 ± 4.4 284 ± 20	-15%
Warpage of cylinder head (bottom face).....	0.05 (0.0020) max	0.10 (0.0039)
Bend (dial reading) of valve push rod.....		0.3 (0.012)
Timing Gear Backlash		
Crankshaft gear/idler gear.....	0.04 - 0.12 (0.0016 - 0.0047)	0.30 (0.0118)
Idler gear/camshaft gear.....	0.04 - 0.12 (0.0016 - 0.0047)	0.30 (0.0118)
Idler gear/fuel injection pump camshaft gear.....	0.04 - 0.12 (0.0016 - 0.0047)	0.30 (0.0118)
Camshaft gear/P.T.O. gear.....	0.08 - 0.19 (0.0031 - 0.0075)	0.30 (0.0118)
Fuel injection pump camshaft gear and oil pump gear.....	0.07 - 0.20 (0.0028 - 0.0079)	0.30 (0.0118)
Lobe height of camshaft.....	35.72 (1.4063)	34.72 (1.3669)

Component	Standard mm (inches)	Repair Limit mm (inches)
<b>ENGINE COMPONENTS</b>		
Lobe height of fuel injection pump camshaft.....	44 (1.73)	43 (1.3669)
Flatness of flywheel.....	0.15 (0.0059) max	0.50 (0.0197)
Clearance between tappet and cylinder block.....		0.15 (0.0059)
Clearance between camshaft journal and bushing.....		0.15 (0.0059)
Clearance between idler gear and shaft.....	0.03 - 0.07 (0.0012 - 0.0028)	0.20 (0.0079)
Warpage of cylinder block top face.....	0.05 (0.0020) max	0.10 (0.0039)
Bore in cylinder block.....	78.0 <sup>+0.03</sup> (3.07 <sup>+0.0012</sup> )	78.2 (3.079)
Taper and out-of- round of cylinder.....	0.01 (0.0004)max	
Piston Pin O.D.....	22.944 - 23.00 (0.90527 - 0.90551)	
Diameter of piston		
Standard.....	77.93 - 77.95 (3.0681 - 3.0689)	77.80 (3.0630)
0.25 (0.0098).....	78.18 - 78.20 (3.0779 - 3.0787)	78.05 (3.0728)
0.50 (0.0197).....	78.43 - 78.45 (3.0878 - 3.0886)	78.30 (3.0827)
Clearance between piston pin and piston.....	0.006 - 0.018 (0.00024 - 0.00071)	0.050 (0.00197)
Clearance between piston ring and groove		
No.1 Compression.....	0.06 - 0.10 (0.0024 - 0.0039)	0.30 (0.0118)
No.2 Compression.....	0.05 - 0.09 (0.0020 - 0.0035)	0.20 (0.0079)
Oil ring.....	0.03 - 0.7 (0.0012 - 0.0028)	0.20 (0.0079)
Clearance between ends of piston ring		
No.1 Compression.....	0.15 - 0.30 (0.0059 - 0.0118)	1.50 (0.059)
No.2 Compression.....	0.15 - 0.35 (0.0059 - 0.0138)	1.50 (0.059)
Oil ring.....	0.20 - 0.40 (0.0079 - 0.0157)	1.50 (0.059)
Clearance between piston and cylinder.....	0.035 - 0.086 (0.00138 - 0.00339)	0.300 (0.01181)
Clearance between crankpin and connecting rod bearing.....	0.025 - 0.072 (0.00098 - 0.00283)	0.150 (0.00591)
Thrust clearance for connecting rod big end.....	0.10 - 0.35 (0.0039 - 0.0138)	0.50 (0.0197)
Connecting rod bend/twist	0.05/100 (0.0020/3.94 max.) 0.15/100 (0.0059/3.94 max.)	

# SERVICE DATA - STANDARDS AND LIMITS

Component	Specified Value / Standard inches(mm)	Repair Limit inches(mm)
-----------	--	----------------------------

## ENGINE COMPONENTS

Crankshaft		
Diameter of journal	51.985 - 52.000 (2.04665 - 2.04724)	
Diameter of crankpin	47.950 - 47.965 1.88779 - 1.88838)	
Runout	0.025 (0.00098)	0.05 (0.0020)
Clearance between journal and main bearing	0.030 - 0.077 (0.00118 - 0.00303)	0.100 (0.00394)
Clearance between crankpin and connecting rod bearing	0.025 - 0.072 (0.00098 - 0.00283)	0.150 (0.00591)
End play	0.050 - 0.175 (0.00197 - 0.00689)	0.500 (0.01969)

## LUBRICATION SYSTEM

Pressure relief valve setting	50 ± 7 psi 3.5 ± 0.5 kgf/cm <sup>2</sup> 343 ± 49 kPa
Pressure difference at which oil pressure switch is closed	7 ± 1.4 psi 0.5 ± 0.1 kgf/cm <sup>2</sup> 49 ± 10 kPa

## FUEL SYSTEM

Injection pressure (valve opening pressure)	1991 <sup>71</sup> psi 140 <sup>45</sup> kgf/cm <sup>2</sup> 13729 <sup>490</sup> kPa
---	---

## STARTER MOTOR

Pinton clearance	0.5 - 2.0 (0.20 - 0.079)
No-load characteristics 33C	
Terminal	11.5V
Current draw	100A maximum
Rpm	3000 minimum
No-load characteristics 44A	
Terminal	11V
Current draw	130A maximum
Rpm	3850 minimum
Brush length	wear limit line
Brush spring tension	3.0 kgf ————— 1.8 kgf 6.6 lbf ————— 4.0 lbf 29.4N ————— 17.7N
Runout of commutator	0.03 ————— 0.10 (0.0012) ————— (0.0039)
Diameter of commutator	32 ————— 31 (1.26) ————— (1.22)
Undercut of mica	0.5 ————— 0.2 (0.020) ————— (0.008)

Component	Sealant	Mating Part
-----------	---------	-------------

## THREAD PARTS

Stop solenoid	Loctite #587 Ultra Blue	Governor case
Water drain joint	Loctite Gasket Sealer #2 or High-Tack Gasket Sealer	Cylinder block
Oil pressure switch	Loctite Gasket Sealer #2 or High-Tack Gasket Sealer	Cylinder block
Torque spring set	Loctite #587 Ultra Blue	Governor case

## PRESS FIT PARTS

Sealing cap	Loctite Gasket Sealer #2 or High-Tack Gasket Sealer	Cylinder block
Sealing cap	Loctite Gasket Sealer #2 or High-Tack Gasket Sealer	Cylinder head
Sealing cap	Loctite Gasket Sealer #2 or High-Tack Gasket Sealer	Cylinder head & block
Expansion plug	Loctite Gasket Sealer #2 or High-Tack Gasket Sealer	Governor block
Dipstick guide	Loctite Gasket Sealer #2 or High-Tack Gasket Sealer	

## OTHERS

Side seal	Loctite #587 Ultra Blue	Cylinder block and main bearing caps
Main bearing caps (front and rear)	Loctite #587 Ultra Blue	Cylinder block
Oil pan	Loctite #5699 Ultra Gray or High-Tack Gasket Sealer	Cylinder block

# SPECIAL TOOLS - ENGINE

**PIN SETTING TOOL [033582]**  
FOR PISTON PIN REMOVAL AND INSTALLATION

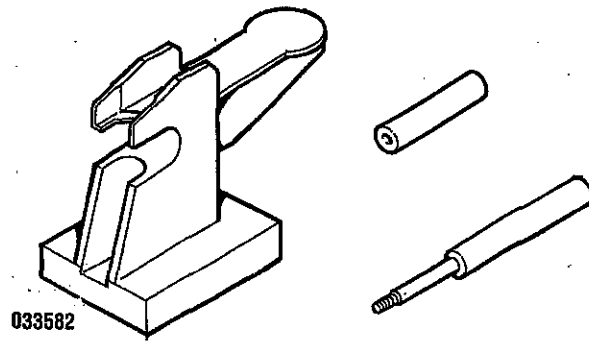

**COMPRESSION GAUGE ADAPTER [039254]**  
FOR COMPRESSION PRESSURE MEASUREMENT

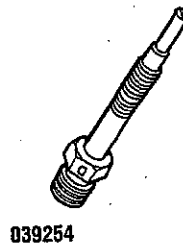

**OIL PRESSURE SWITCH SOCKET WRENCH**  
TO REMOVE THE OIL PRESSURE SWITCH



**CAMSHAFT BUSHING INSTALLER [033583]**  
FOR REMOVING AND INSTALLING THE FRONT  
CAMSHAFT BUSHING

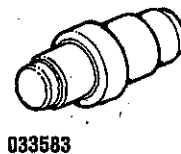

THE ABOVE TOOLS ARE AVAILABLE FROM YOUR WESTERBEKE OR MITSUBISHI DEALER.

NOTE: IN ADDITION TO THESE TOOLS THE FOLLOWING ADDITIONAL TOOLS WOULD BE NEEDED:

BEARING PULLER, VALVE SEAT CUTTER TOOL, PROPER DIAL GAUGES, VALVE GUIDE INSTALLER TOOL, VALVE SPRING COMPRESSOR, SNAP RING PLIERS, ETC.

ALSO REFER TO SPECIAL TOOLS - GENERATOR IN THIS MANUAL.

# TORQUE SPECIFICATIONS

## MAJOR BOLTS AND NUTS

Bolt or Nut	Diameter	Pitch	Width across flats	Clamp length	TORQUE		
					kg -m	ft - lb	N -m
Alternator Bracket	---	---	---	---	3.8-5.3	27-38	36.6
Back Plate	---	---	---	---	3.3-4.8	24-35	32.5
Connecting Rod Cap	M9	1.0	14	---	3.55±0.25	27±7 2	34.8±2.5
Coolant Pump	---	---	---	---	1.6±2.4	12-17	17.2
Coolant Pump Pulley	---	---	---	---	1.6±2.4	12-17	17.2
Coolant Temperature Sender	---	---	---	---	1.2±1.8	9-13	12.2
Coolant Temperature Switch	---	---	---	---	1.2±1.8	9-13	12.2
Crankshaft Pulley Nut	M18	1.5	27	---	17.5±2.5	127±18	172±25
Cylinder Head Bolt	M10	1.25	14	87	9±0.5	65 ± 4	88 ± 5
Damper Plate	---	---	---	---	1.9± 2.7	14-20	8.9
Delivery Valve Holder	---	---	19	---	4.5±0.5	32±5 4	44± 5
Engine Mounts	---	---	---	---	3.2±4.7	23-34	31.1
Exhaust Manifold	---	---	---	---	1.6±2.4	12-17	7.2
Flywheel Bolt	M12	1.25	19	29	13.5±0.5	98±4	132±5
Fuel Filter Assembly	---	---	---	---	4.6±6.8	33-49	44.7
Fuel Injection Nozzle Holder	M20	1.5	21	---	5.5±0.5	40±4 4	54±5
Fuel Injection Pipe Nut	M12	1.5	---	---	3±0.5	22±4	29±5
Fuel Leak-Off Pipe Nut	M12	1.5	18	---	2.75±0.25	20± 2	27±2.5
Fuel Solenoid Locknut	---	---	---	---	4.0±0.5	28.9±36.2	39.18
Glow Plug	M10	1.25	12	60	1.75±0.25	12±7 2	17.2±2.5
Glow Plug Connection Plate	M4	0.7	8	---	0.125±0.025	0.9±0.2	1.2±0.2
Intake Manifold	---	---	---	---	1.6±2.4	12-17	16.2
Main Bearing Cap Bolt	M10	1.25	17	81	5.25±0.25	38±2	51.5±2.5
Oil Filter	M20	1.5	---	---	1.2±0.1	8.7± 0.7	12±1
Oil Pan Bolt	M8	1.25	12	25	2.8±0.3	20.3±2.2	27±5.3
Oil Pan Drain Plug	M14	1.5	22	10	4.0±0.5	29±4	39±5
Oil Pressure Sender	---	---	---	---	1.2±1.8	9-13	12.2
Oil Pressure Switch	PT1/8	---	26	11	1±0.2	7.2±1.4	10±2
Pressure Relief Valve	M22	1.5	22	33	5.0±0.5	36±4	49±5
Rear Plate Bolt (stamping)	M8	1.25	12	16	1.15±0.15	8.3±1.1	11.3±1.5
Rear Plate Bolt (standard)	M12	1.25	17	28	6.5±0.1	47±7	64±10
Retaining Nut for Delivery Valve Holder Body	M16	0.75	19	---	3.75±0.25	27±2	37±2.5
Rocker Cover Bolt	M8	1.25	12	40	1.15±0.15	8.3±1.1	11.3±1.5
Rocker Shaft Bracket Bolt	M8	1.25	12	581	1.5±0.5	11±4	14.7±5
Sliding Sleeve Shaft	M10	1.25	14	29.5	3.6±0.6	26±4	35±6
Special Nut for Torque Spring Set	M12	1.0	17	---	2±0.5	14±4	20±5
Starter B Terminal	M8	1.25	12	---	1.1±0.1	8 0±7	10.8±1
Stop Solenoid	M30	1.5	36	---	4.5±0.5	32±5 4	44±5
Thermostat Housing	---	---	---	---	0.3-0.45	2-3	2.7
Thermoswitch	M16	1.5	17	31.5	2.3±0.4	16.6 ± 3	22.6 ± 4

# PROPULSION MODELS WIRING SCHEMATIC #39144

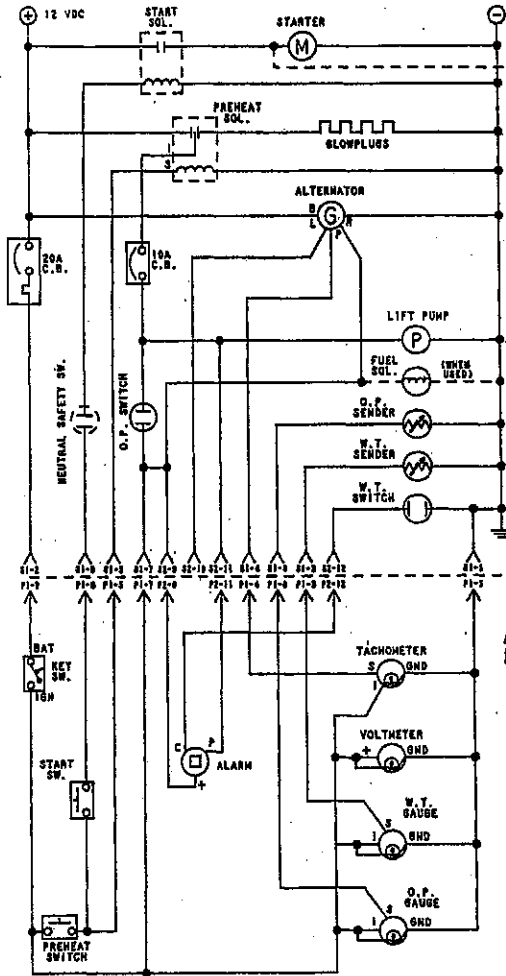

ADMIRAL PANEL

CAPTAIN PANEL

- NOTES:**
1. THIS PRODUCT IS PROTECTED BY A MANUAL RESET CIRCUIT BREAKER LOCATED NEAR THE STARTER. EXCESSIVE CURRENT WILL CAUSE THE BREAKER TO TRIP AND THE ENGINE WILL SHUT DOWN. THE BUILDER/OWNER MUST BE SURE THAT THE INSTRUMENT PANEL, WIRING, AND ENGINE ARE INSTALLED TO PREVENT CONTACT BETWEEN ELECTRICAL DEVICES AND SEAWATER.
  2. AN ON-OFF SWITCH SHOULD BE INSTALLED BETWEEN THE BATTERY AND STARTER TO DISCONNECT THE BATTERY IN AN EMERGENCY AND WHEN LEAVING THE BOAT. A SWITCH WITH A CONTINUOUS RATING OF 175 AMPS. AT 12 VDC WILL SERVE THIS FUNCTION. THIS SWITCH SHOULD NOT BE USED TO MAKE OR BREAK THE CIRCUIT.
  3. THE PINK WIRE AT PLUG 2 IS UNUSED AND SHOULD BE INSULATED, CAPTAIN PANEL ONLY.
  4. THE GRAY WIRE AT PLUG 2 IS UNUSED AND SHOULD BE INSULATED, ADMIRAL PANEL ONLY.

NOTE: WIRE FOR BATTERY ATTACHMENT WILL NEED TO BE UPGRADED TO AN 8 GAUGE FROM 10 GAUGE

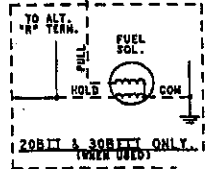

MITSUBISHI 50 AMP. ALT.

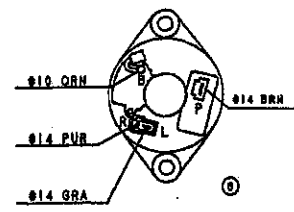

PRESTOLITEVEECE-NEVILLE 90 AMP. ALT.

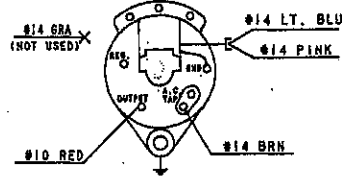
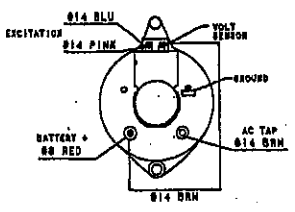

PRESTOLITE 72 AMP. ALT.

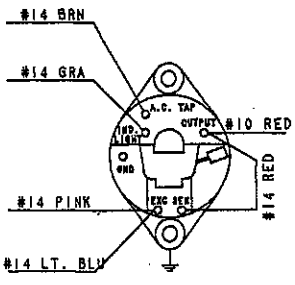

UNIVERSAL PROPULSION  
PRESTOLITE 51 AMP. ALT.

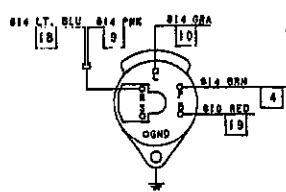
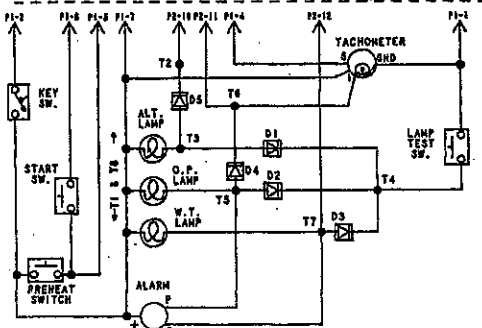

**51 AMP. ALTERNATOR**  
STANDARD ALTERNATOR ON THE  
63B IX, 63C IX, 71B IX, 82B IX,  
108B VI, & 108C VI.

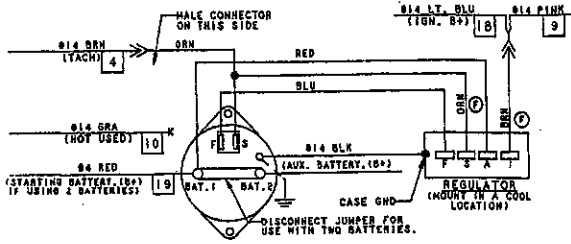

OPTIONAL ALTERNATORS ©

AVAILABLE ON THE 63B IX, 63C IX, 71B IX, 82B IX, 108B VI, & 108C VI ONLY.



# PROPULSION MODELS WIRING DIAGRAM #39144

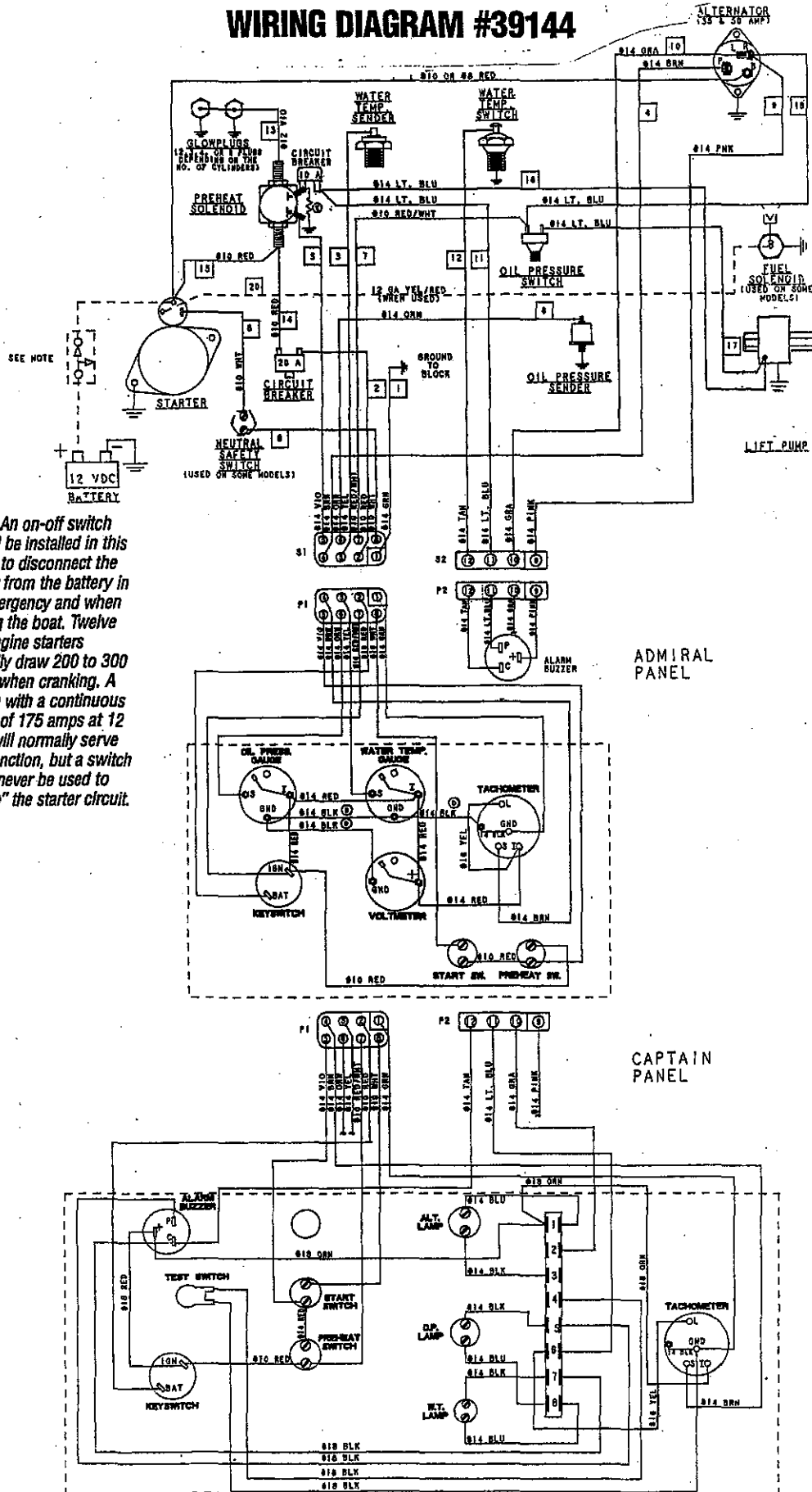

**NOTE:** An on-off switch should be installed in this circuit to disconnect the starter from the battery in an emergency and when leaving the boat. Twelve volt engine starters typically draw 200 to 300 amps when cranking. A switch with a continuous rating of 175 amps at 12 VDC will normally serve this function, but a switch must never be used to "make" the starter circuit.

# 44A, 44B, 44C FOUR ENGINE SPECIFICATIONS

## SPECIFICATIONS

Engine Type	Diesel, four-cycle, four-cylinder, fresh water-cooled, vertical in-line overhead valve mechanism.
Displacement	107.3 cubic inches (1.758 liter)
Aspiration	Naturally aspirated.
Combustion Chamber	Swirl type.
Bore & Stroke	3.07 x 3.62 inches (78 x 92 mm)
Firing Order	1 - 3 - 4 - 2
Direction of Rotation	Clockwise, when viewed from the front.
Compression Ratio	22:1
Inclination	Continuous 14° Temporary 25° (not to exceed 30 min.)

## TUNE-UP SPECIFICATIONS

Compression Pressure Minimum	427 psi (30 kg/cm <sup>2</sup> ) at 280 rpm 384 psi (27 kg/cm <sup>2</sup> )
Engine Timing	17° BTDC (44A/Four) 21° BTDC (44B/Four) 23° BTDC (44C/Four)
Injector Pressure	1991 + 71 - 0 psi (140 + 5 - 0 kgf/cm <sup>2</sup> ).
Valve Seat Angle	Intake 45° Exhaust 30°
Valve Clearance (engine cold)	0.25mm (0.0098 inches)
Engine Speed	3600 rpm (44A/Four) 3000 rpm (44B/Four) 3000 rpm (44CB/Four)
Horsepower Rating	44A/Four 40Hp at 3600 rpm 44B/Four 41Hp at 3000 rpm 44C/Four 41Hp at 3000 rpm

## ELECTRICAL SYSTEM

Starting Battery	12 Volt, (-) negative ground
Battery Capacity	600 - 800 Cold Cranking Amps (CCA)
DC Charging Alternator	51 Amp rated, belt-driven
Starting Aid	Glow plugs, sheathed type
Starter	12 Volt, reduction gear
Cold Cranking Amp Draw	150 - 175 DC Amps

## FUEL SYSTEM

General	Open flow, self priming.
Fuel	No. 2 diesel oil (cetane rating of 45 or higher).
Fuel Injection Pump	In-line plunger type (BOSCH).
Nozzle	Throttle type.
Fuel Filter	Cartridge Type (PN#030200) Inlet Fuel Filter PN#048076
Air cleaner	Replaceable paper filter cartridge.
Air Flow (engine combustion)	110 cfm (3.1 cmm) at 3600 rpm. 83 cfm (2.6 cmm) at 3000 rpm.
Fuel Lift Pump	12 volt DC lift capacity of 5' (1.5 mm) wet

## COOLING SYSTEM

General	Fresh water-cooled block, thermostatically-controlled with heat exchanger.
Operating Temperature	170 - 190° F (77 - 88° C)
Fresh Water Pump	Centrifugal type, metal impeller, belt-driven.
Raw Water Pump	Positive displacement, rubber impeller, belt-driven.
Raw Water Flow (measured before discharge into exhaust elbow) Approximate	44A/Four 9.5 gpm at 3600 rpm. 44B/Four 8.0 gpm at 3000 rpm 44C/Four 8.0 gpm at 3000 rpm.
System Capacity (Fresh Water)	8.0 US qts (7.6 liters)

## LUBRICATION SYSTEM

General	Pressure fed system.
Oil Filter	Full flow, paper element, spin-on type.
Sump Capacity (not including filter)	5.7 U.S. qts (5.4 liters)
Operating Oil Pressure (engine hot)	50 - 60 psi (3.5 - 4.2 kg/cm <sup>2</sup> )
Oil Grade	API Specification CF or CG-4, SAE 30, 10W-30, 15W-40

# 35C, 35D, 35E THREE ENGINE SPECIFICATIONS

## SPECIFICATIONS

Engine Type	Diesel, four-cycle, three-cylinder, fresh water-cooled, vertical in-line overhead valve mechanism..
Displacement	80.4 cubic inches (1.318 liter)
Aspiration	Naturally aspirated.
Combustion Chamber	Swirl type.
Bore & Stroke	3.07 x 3.62 inches (78 x 92 mm)
Firing Order	1 - 3 - 2
Direction of Rotation	Clockwise, when viewed from the front.
Compression Ratio	22:1
Inclination	Continuous 14° Temporary 25° (not to exceed 30 min.)

## TUNE-UP SPECIFICATIONS

Compression Pressure Minimum	427 psi (30 kg/cm <sup>2</sup> ) at 280 rpm 384 psi (27 kg/cm <sup>2</sup> )
Engine Timing	17° BTDC (35C/Three) 21° BTDC (35D/Three) 23° BTDC (35E/Three)
Injector Pressure	1991 + 71 - 0 psi (140 + 5 - 0 kg/cm <sup>2</sup> ).
Valve Seat Angle	Intake 45° Exhaust 30°
Valve Clearance (engine cold)	0.25mm (0.0098 inches)
Engine Speed	3600 rpm (35C/Three) 3000 rpm (35D/Three) 3000 rpm (35E/Three)
Horsepower Rating	35C/Three 40Hp at 3600 rpm 35D/Three 41Hp at 3000 rpm 35E/Three 41Hp at 3000 rpm

## ELECTRICAL SYSTEM

Starting Battery	12 Volt, (-) negative ground
Battery Capacity	600 - 800 Cold Cranking Amps (CCA)
DC Charging Alternator	51 Amp rated, belt-driven
Starting Aid	Glow plugs, sheathed type
Starter	12 Volt, reduction gear
Cold Cranking Amp Draw	150 - 175 DC Amps

## FUEL SYSTEM

General	Open flow, self priming.
Fuel	No. 2 diesel oil (cetane rating of 45 or higher).
Fuel Injection Pump	In-line plunger type (BOSCH).
Nozzle	Throttle type.
Fuel Filter	Cartridge Type (PN#030200) Inlet Fuel Filter PN#048076)
Air cleaner	Replaceable paper filter cartridge.
Air Flow (engine combustion)	83.7 cfm (2.3 cmm) at 3600 rpm. 69.7 cfm (1.9 cmm) at 3000 rpm.
Fuel Lift Pump	12 volt DC lift capacity of 5' (1.5 mm) wet

## COOLING SYSTEM

General	Fresh water-cooled block, thermostatically-controlled with heat exchanger.
Operating Temperature	170 - 190° F (77 - 88° C)
Fresh Water Pump	Centrifugal type, metal impeller, belt-driven.
Raw Water Pump	Positive displacement, rubber impeller, belt-driven.
Raw Water Flow (measured before discharge into exhaust elbow) Approximate	35C/Three 9.5 gpm at 3600 rpm. 35D/Three 8.0 gpm at 3000 rpm. 35E/Three 8.0 gpm at 3000 rpm.
System Capacity (Fresh Water)	5.0 US qts (4.7 liters)

## LUBRICATION SYSTEM

General	Pressure fed system.
Oil Filter	Full flow, paper element, spin-on type.
Sump Capacity (not including filter)	3.9 U.S. qts (3.7 liters)
Operating Oil Pressure (engine hot)	50 - 60 psi (3.5 - 4.2 kg/cm <sup>2</sup> )
Oil Grade	API Specification CF or CG-4, SAE 30, 10W-30, 15W-40

# DC ELECTRICAL SYSTEM

## ALTERNATOR

The charging system consists of a DC belt driven alternator with a voltage regulator, an engine DC wiring harness, a mounted DC circuit breaker and a battery with connecting cables. Because of the use of integrated circuits (IC's), the electronic voltage regulator is very compact and is mounted internally or on the back of the alternator.

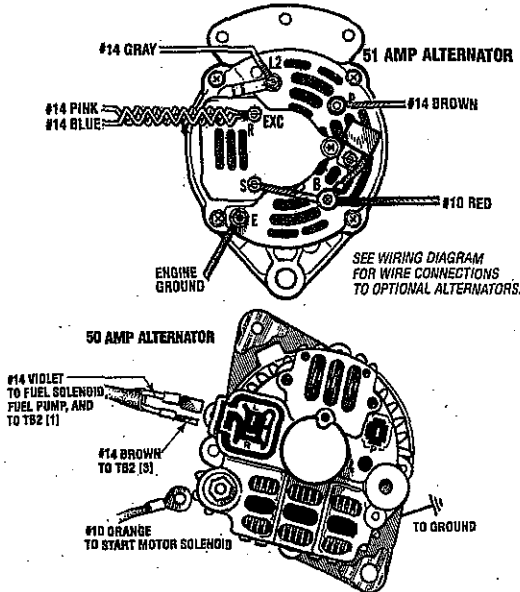

## ALTERNATOR TROUBLESHOOTING

Use this troubleshooting section to determine if a problem exists with the charging circuit or with the alternator. If it is determined that the alternator or voltage regulator is faulty, have a qualified technician check it.

The alternator charging circuit charges the starting battery and the service battery. An isolator with a diode, a solenoid or a battery selector switch is usually mounted in the circuit to isolate the batteries so the starting battery is not discharged along with the service battery. If the alternator is charging the starting battery but not the service battery, the problem is in the service battery's charging circuit and not with the alternator.

### Testing the Alternator

**CAUTION:** Before starting the engine make certain that everyone is clear of moving parts! Keep away from sheaves and belts during test procedures.

**WARNING:** When testing with a multimeter: DC and AC circuits are often mixed together in marine applications. Always disconnect a shore power cord, isolate DC and AC converters, and shut down the engine before performing DC testing. No AC tests should be made without a proper knowledge of AC circuits.

1. Start the engine.
2. After the engine has run for a few minutes, measure the starting battery voltage at the battery terminals using a multimeter set on DC volts.
  - a. If the voltage is increasing toward 14 volts, the alternator is working; omit Steps 3 through 8 and go directly to "Checking the Service Battery" on the next page.
  - b. If the voltage remains around 12 volts, a problem exists with either the alternator or the charging circuit; continue with Steps 3 through 8.

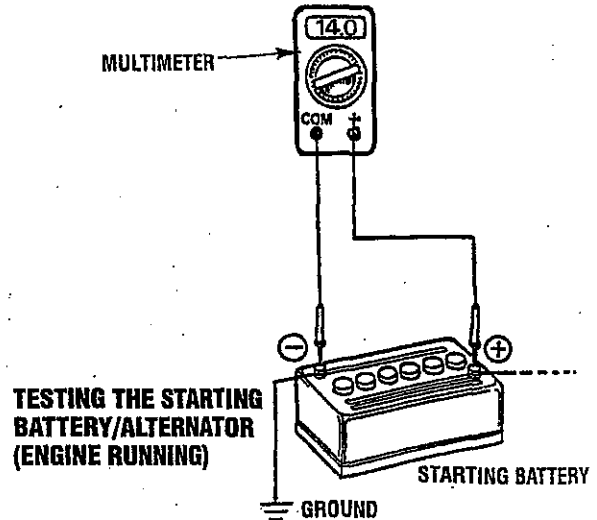

TESTING THE STARTING BATTERY/ALTERNATOR (ENGINE RUNNING)

3. Turn off the engine. Inspect all wiring and connections. Ensure that the battery terminals and the engine ground connections are tight and clean.

**CAUTION:** To avoid damage to the battery charging circuit, never shut off the engine battery switch when the engine is running!

4. If a battery selector switch is in the charging circuit, ensure that it is on the correct setting.
5. Turn on the ignition switch, but do not start the engine.
6. Check the battery voltage. If the battery is in good condition, the reading should be 12 to 13 volts.

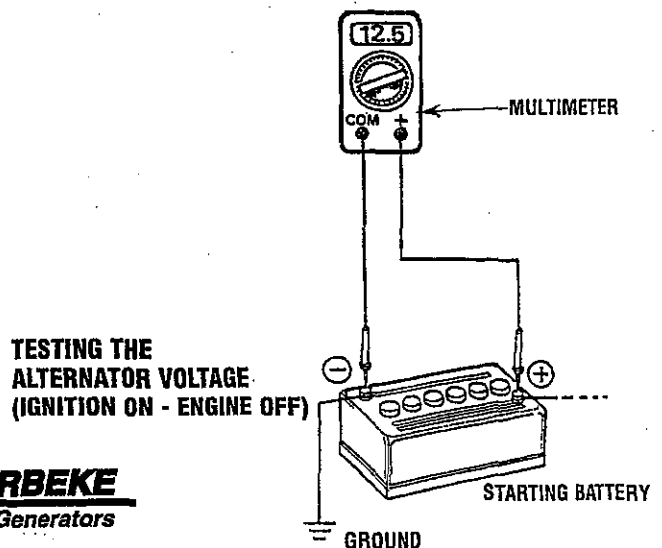

TESTING THE ALTERNATOR VOLTAGE (IGNITION ON - ENGINE OFF)

# DC ELECTRICAL SYSTEM

7. Now check the voltage between the alternator output terminal (B+) and ground. If the circuit is good, the voltage at the alternator will be the same as the battery, or if an isolator is in the circuit the alternator voltage will be zero. If neither of the above is true, a problem exists in the circuit between the alternator and the battery. Check all the connections - look for an opening in the charging circuit.

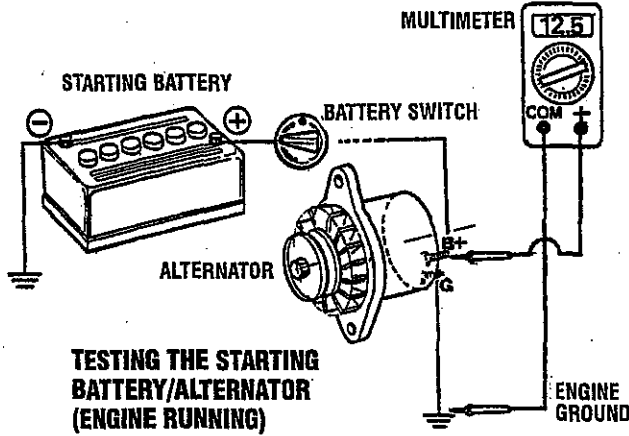

8. Start the engine again. Check the voltage between the alternator output and ground. The voltage reading for a properly operating alternator should be between 13.5 and 14.5 volts. If your alternator is over- or under-charging, have it repaired at a reliable service facility.

**NOTE:** Before removing the alternator for repair, use a voltmeter to ensure that 12 volts DC excitation is present at the EXC terminal if the previous test showed only battery voltage at the B output terminal.

If 12 volts is not present at the EXC terminal, trace the wiring and look for breaks and poor connections.

## Checking the Service Battery

Check the voltage of the service battery. This battery should have a voltage between 13 and 14 volts when the engine is running. If not, there is a problem in the service battery charging circuit. Troubleshoot the service battery charging circuit by checking the wiring and connections, the solenoid, isolator, battery switch, and the battery itself.

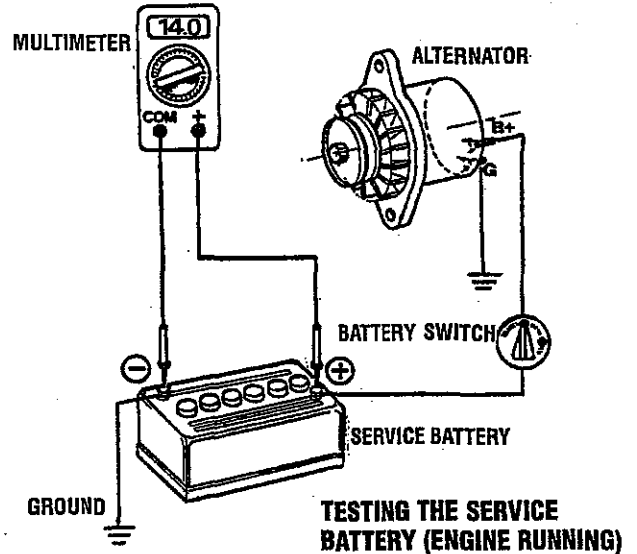

**CAUTION:** To avoid damaging the alternator diodes, do not use a high voltage tester (i.e. a megger) when performing tests on the alternator charging circuit.

## 12 VOLT DC CONTROL CIRCUIT

The engine has a 12 volt DC electrical control circuit that is shown on the wiring diagrams in this manual. Refer to these diagrams when troubleshooting or when servicing the DC electrical system.

**CAUTION:** To avoid damage to the battery charging circuit, never shut off the engine battery switch while the engine is running. Shut off the engine battery switch, however, to avoid electrical shorts when working on the engine's electrical circuit.

## BATTERY

The minimum recommended capacity of the battery used in the engine's 12 volt DC control circuit is 600 – 900 Cold Cranking Amps (CCA).

## Battery Care

Review the manufacturer's recommendations and then establish a systematic maintenance schedule for your engine's starting batteries and house batteries.

- Monitor your voltmeter for proper charging during engine operation.
- Check the electrolyte level and specific gravity with a hydrometer.
- Use only distilled water to bring electrolytes to a proper level.
- Make certain that battery cable connections are clean and tight to the battery posts (and to your engine).
- Keep your batteries clean and free of corrosion.

**WARNING:** Sulfuric acid in lead batteries can cause severe burns on skin and damage clothing. Wear protective gear.

# WESTERBEKE 51A MANDO ALTERNATOR

## DISASSEMBLY AND TESTING

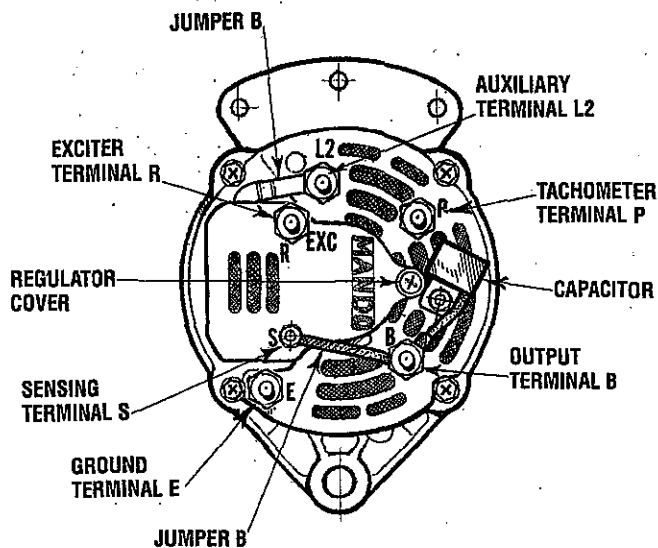
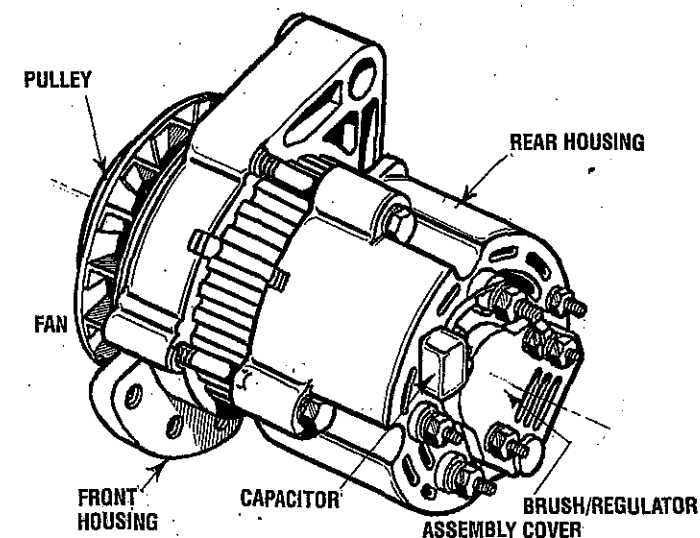

### TESTING THE OUTPUT CIRCUIT

1. Connect the positive voltmeter lead to the output terminal B and connect the negative lead to the ground terminal E on the alternator.
2. Wiggle the engine wiring harness while observing the voltmeter. The meter should indicate the approximate battery voltage, and should not vary. If no reading is obtained, or if the reading varies, check the alternator output circuit for loose or dirty connections or damaged wiring.

**NOTE:** Prior to any alternator testing, inspect the entire alternator system wiring for defects. Check all connections for tightness and cleanliness, particularly battery cable clamps and battery terminals. Inspect the alternator drive belt for excessive wear and replace if necessary. Also adjust for proper belt tension.

**WARNING:** A failed alternator can become very hot. Do not touch until the alternator has cooled down.

**WARNING** Before starting the engine, make certain that everyone is clear of moving parts! Keep away from sheaves and belts during test procedures.

**WARNING** Multimeters and DC Circuits  
DC and AC circuits are often mixed together in marine applications. Always disconnect shore power cords, isolate DC and AC converters and shut down generators before performing DC testing. No AC tests should be made without proper knowledge of AC circuits.

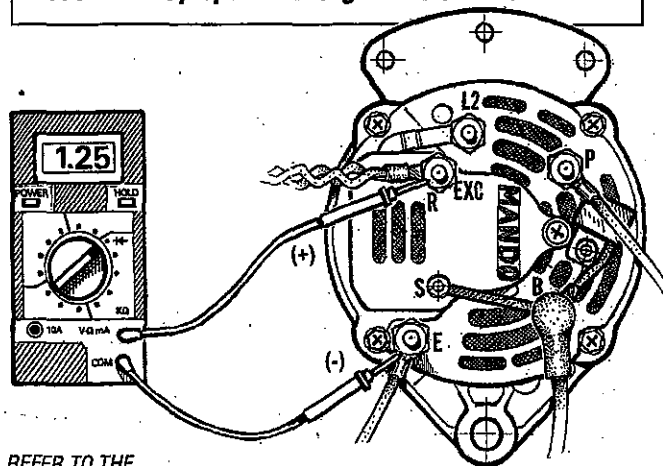

REFER TO THE WIRING DIAGRAMS FOR THE ABOVE WIRING HARNESS CONNECTIONS

### TESTING THE EXCITATION CIRCUIT

1. Connect the positive (+) voltmeter lead to the excitation terminal R on the alternator and the negative (-) lead to the ground terminal E on the alternator.
2. Turn the ignition switch to the on position and note the voltmeter reading. The reading should be 1.3 to 2.5 volts (see illustration).
3. If the reading is between .75 and 1.1 volts, the rotor field circuit probably is shorted or grounded. Disassemble the alternator and test the rotor as described under *CLEAN AND TEST ALTERNATOR COMPONENTS* in this section.
4. If the reading is between 6.0 and 7.0 volts, the rotor field circuit probably is open. Remove the regulator and inspect it for worn brushes or dirty slip rings. Replace the brushes if they are less than 1/4in. (6 mm) long. If the brushes and slip rings are in good condition, disassemble the alternator and test the rotor, as outlined under *CLEAN AND TEST ALTERNATOR COMPONENTS* in this section.

# MANDO ALTERNATOR SERVICE

## TESTING THE EXCITER LEAD

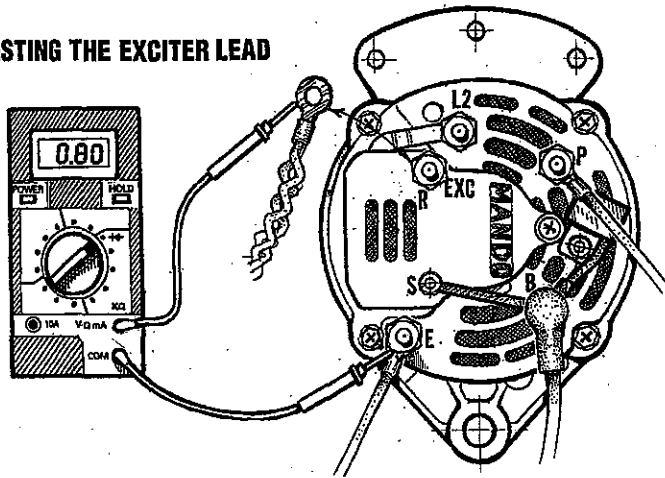

5. If no reading is obtained, an open exists in the alternator-excitation lead or in the excitation circuit of the regulator. Disconnect the lead from exc terminal R. Connect the positive voltmeter lead to the excitation lead and the negative voltmeter lead to ground terminal E. If the voltmeter now indicates an approximate battery voltage, the voltage regulator is defective and must be replaced. If no voltage is indicated, check the excitation circuit for loose or dirty connections or damaged wiring.

## TEST VOLTAGE REGULATOR

Perform this test to determine if the voltage regulator is operating correctly, using a 0 – 20 volt DC voltmeter.

**NOTE:** The battery must be fully charged to obtain a proper voltage reading in this test. If necessary, charge the battery with a battery charger or allow the engine to run a sufficient length of time to fully charge the battery before taking a reading.

1. Connect the positive (+) voltmeter lead to the positive battery terminal and the negative (-) voltmeter lead to the negative terminal.
2. Start the engine and run it at fast idle until the engine reaches its normal operating temperature. Adjust the engine speed to 1500 – 2000 rpm and observe the voltmeter for the highest reading. The reading should be between 13.7 and 14.7 volts.
3. If the reading is high, check for a loose or dirty alternator ground lead connection. If the connection is good, the voltage regulator is faulty and must be replaced. Be sure to disconnect the battery cables before attempting to remove the alternator.
4. If the reading is low:
  - a. Stop the engine and remove the alternator wiring connections.
  - b. Remove the Phillips cover screw from the regulator cover (see illustration).
  - c. Remove the nut from the output terminal and the nut from the sensing terminal, and remove Jumper (A).
  - d. Remove another nut from the sensing terminal, and the nut from the excitation terminal.

- e. Remove the regulator cover.
- f. Temporarily re-install Jumper (A) and all associated nuts. Leave Jumper (B) installed.
- g. Remove the plastic plug from the side of the regulator.
- h. Connect a jumper between the top brush lead and the ground.

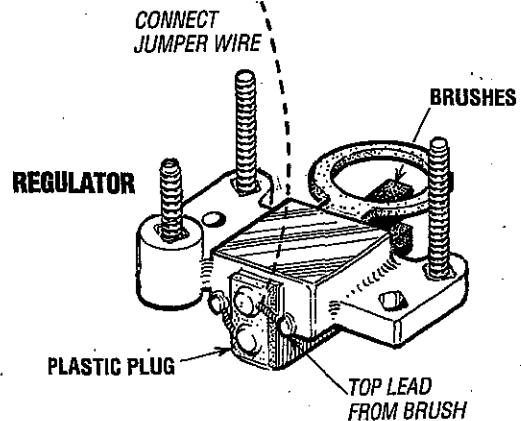
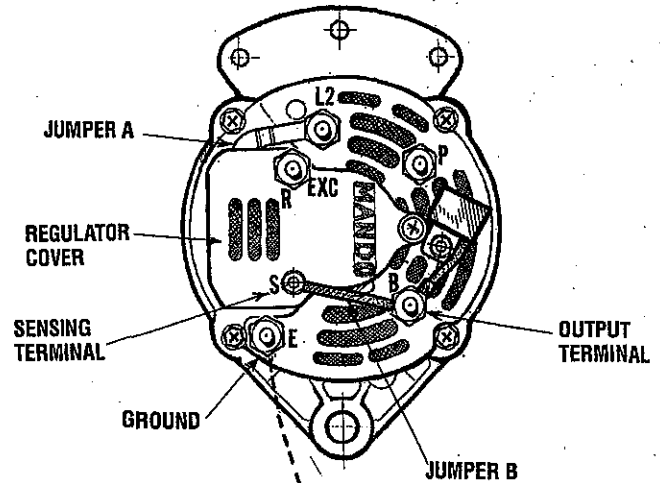

- i. Repeat steps 1 and 2.

**NOTE:** Do not let the voltage exceed 16 volts.

- j. If a voltmeter reading of 14.5 volts or above is now obtained, the voltage regulator is faulty and must be replaced. If the voltmeter reading is below 14.5 volts, inspect the brushes and slip rings for wear, dirt or damage. If the brushes and slip rings are good, the alternator is fault internally. Disassemble the alternator and test the components, as outlined in this section.

# MANDO ALTERNATOR SERVICE

## REMOVE ALTERNATOR

1. Disconnect the negative (-) battery ground cable.
2. Disconnect the wiring leads.
3. Loosen the screws. Holding the alternator, rotate it toward the engine and lift the belt off the pulley.
4. Remove the screws and washers and remove the alternator.

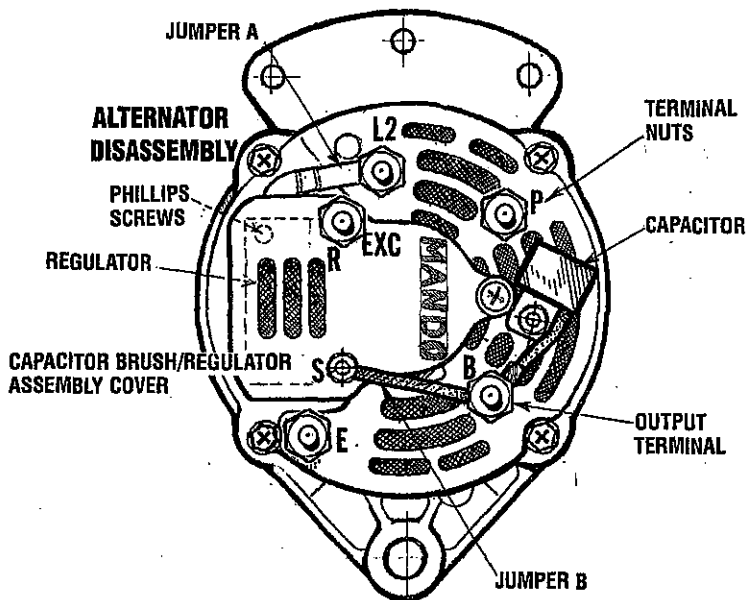

10. Place an oversized V-belt around the pulley and fasten the pulley in a vise.
11. Use a 7/8 in. box wrench to loosen and remove the pulley nut.
12. Remove the pulley nut, lockwasher, pulley, fan, and spacer.

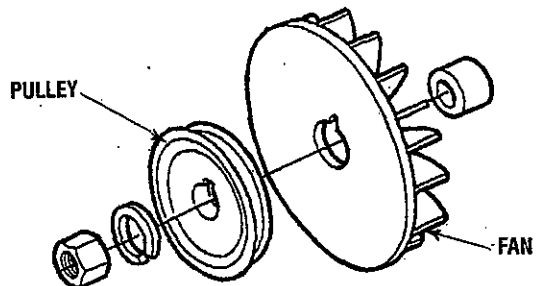

PULLEY AND FAN COMPONENTS

**CAUTION:** DO NOT insert screwdriver blades more than 1/16 in. (1.6 mm). Damage to the stator winding could result from deeper penetration.

**NOTE:** Score the stator, and the front and rear housings so the unit may be reassembled correctly.

## DISASSEMBLE ALTERNATOR

1. Remove the terminal nuts to remove the jumper (see illustration).
2. Remove the remaining terminal nuts.
3. Remove the capacitor.
4. Remove the Phillips screw from the regulator cover.
5. Remove the brush/regulator-assembly cover.
6. Remove the nut from the terminal.
7. Remove the jumper.
8. Remove the terminal insulators.
9. Remove the two Phillips screws and remove the brush/regulator assembly.

13. Remove the four through-bolts and carefully pry the front housing away from the rear housing using two screwdrivers.

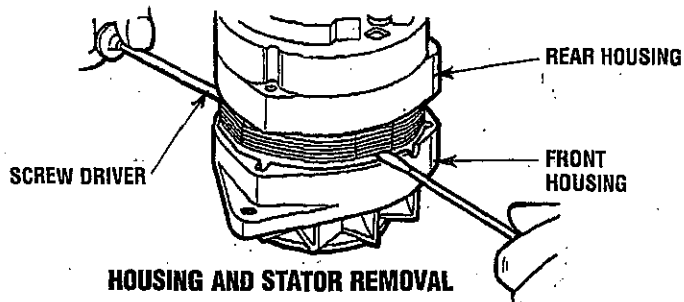

HOUSING AND STATOR REMOVAL

14. Carefully push the rotor assembly out of the front housing and rear housing.

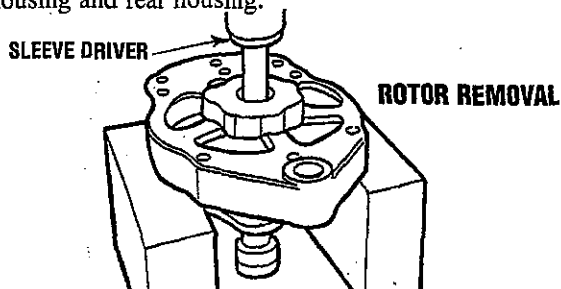

**NOTE:** If the bearing is removed from the housing, a new bearing must be installed.

15. After removing the three bearing locking screws, carefully press the front bearing out of the housing. Press against the inner race of the bearing.

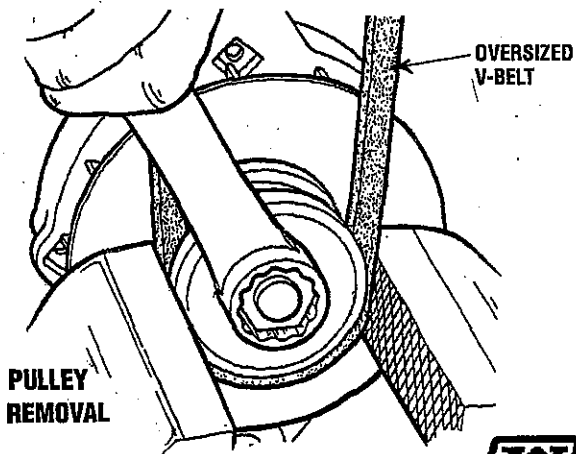



# MANDO ALTERNATOR SERVICE

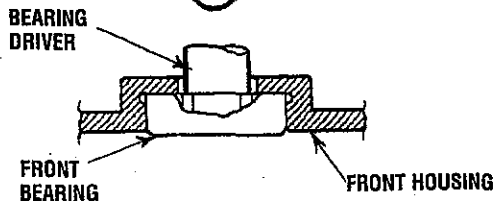
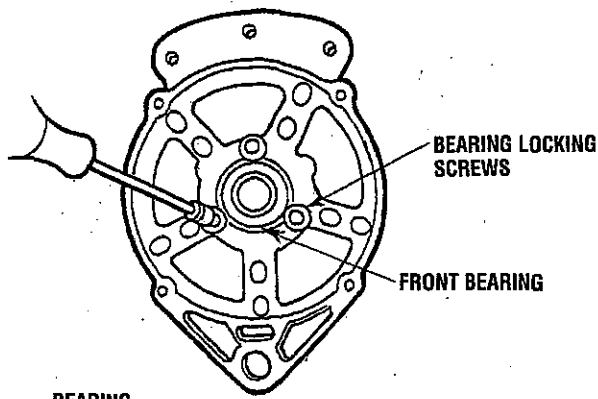

16. Remove the rectifier assembly by removing the Phillips screw and lifting out the assembly.

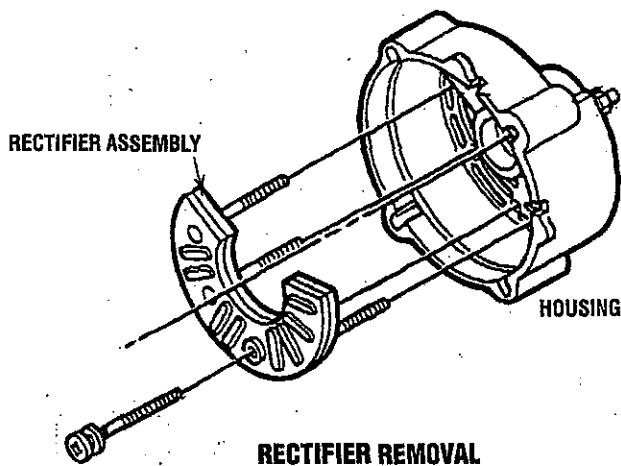

## CLEAN AND TEST ALTERNATOR COMPONENTS

1. Inspect and test the brush/regulator assembly. The brush set may be reused if the brushes are 1/4 in. (6 mm) or longer. The brushes must not be oil soaked, cracked or grooved.

Test for continuity between 1 and 2, and 3 and 4 using a test lamp or an ohmmeter. These checks will indicate a good brush/regulator assembly; replace the complete assembly, if necessary.



TESTING BRUSH ASSEMBLY

2. Inspect and test the diode-trio assembly:

- a. Using a commercial diode tester, a 12-volt DC test lamp or an ohmmeter, check the resistance between each of the three diode terminals and the indicator light stud.

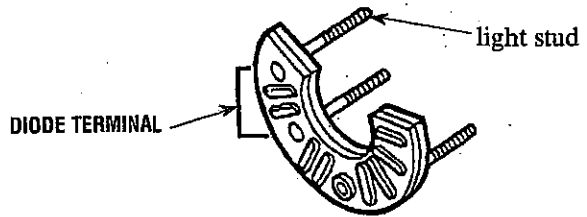

- b. Reverse the tester leads and repeat the resistance checks.
- c. A very low resistance should be indicated in one direction and a very high resistance should be indicated in the other direction if the diodes are normal.
- d. If any diode appears to be defective, replace the complete assembly. Do not attempt to replace an individual diode.

3. Test the diode-rectifier bridge as follows:

- a. Using a commercial diode tester, check for continuity from each of three terminals to the output terminal.

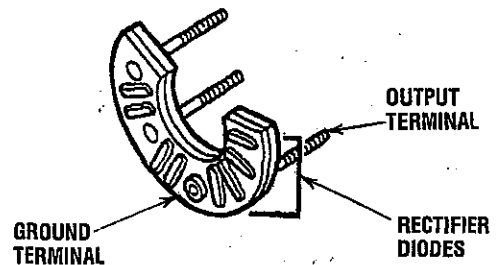

- b. Reverse the tester leads and repeat Step a.
- c. Continuity should exist in only one direction and all diodes should check alike.
- d. Perform the same continuity checks between the three terminals and strap ground terminal. This should show continuity in only one direction through the diodes and all diodes should check alike.
- e. If any diode appears to be defective, replace the rectifier assembly.

# MANDO ALTERNATOR SERVICE

4. Clean and inspect the front and rear housings:
  - a. Inspect the rear housing for cracks or breaks in the casting, stripped threads or a damaged bearing bore. Replace the housing if any of these conditions exist.
  - b. Inspect the front housing for cracks, stripped or damaged threads in the adjusting ear, or an out-of-round bore in the mounting foot. If possible, correct slightly damaged threads using a tap. Replace the housing, if necessary.
  - c. If the housings are to be reused, clean them in solvent and dry with compressed air.

5. Clean and inspect the rotor shaft bearings:

**NOTE:** Do not use a solvent on the rear rotor bearing since it is serviced as a unit with the rotor.

- a. The bearings should be wiped clean with a lint-free cloth containing a moderate amount of commercial solvent. Do not immerse a bearing in solvent, or use pressurized solvent or air.
- b. Check the bearings for obvious damage, looseness or rough rotation. Replace a bearing if any doubt exists as to its condition.

**NOTE:** If the rear rotor bearing needs replacement, replace the entire rotor.

6. Inspect the belt pulley for rough or badly worn belt grooves or keyway, and for cracks or breaks. Remove minor burrs and correct minor surface damage; replace a badly worn or damaged pulley.

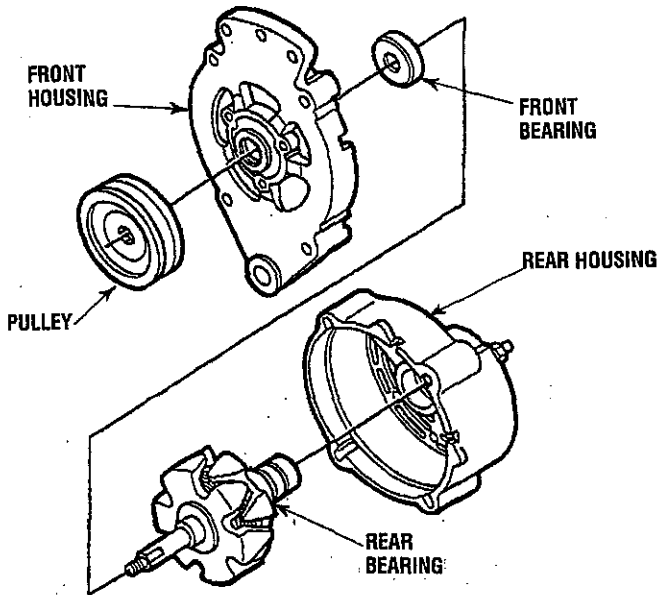

7. Test the stator windings as follows:
  - a. Using an ohmmeter or test lamp, check for continuity between all three leads (1, 2, and 3). A low ohm reading or lit test lamp should be observed.

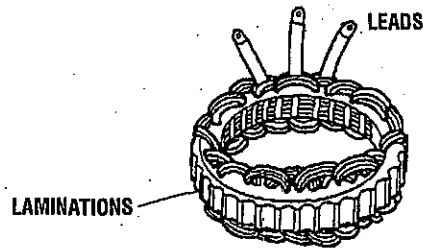

- b. Check the resistance from each lead (1, 2, and 3) to the laminations (4). There should be no continuity if the insulation is good.
- c. Inspect the stator windings for signs of discoloration. A discolored winding should be replaced.
- d. If a winding shows a high resistance or an open circuit between any two of the three winding terminals or indicates poor insulation between the windings and the laminations, the stator must be replaced.

8. Check the rotor assembly as follows:

**NOTE:** If slip rings need to be replaced, you must replace the entire rotor.

- a. Visually inspect for physical defects such as damaged shaft threads, worn or damaged bearing areas, burned or pitted slip rings or scuffed pole fingers.
  - b. Measure the winding resistance across the slip rings (A). Place the ohmmeter leads on the edges of the slip rings, not on the brush contact surfaces. The correct winding resistance at 70 – 80° F (21 – 27° C) is 4.1 to 4.7 ohms.
  - c. Minor burning or pitting of the slip ring surfaces can be removed using a crocus cloth. Thoroughly wipe the slip rings clean after polishing, removing all grit and dust.
  - d. Check for a grounded slip ring or rotor winding by measuring the resistance from each slip ring to the rotor body or pole finger (B). An open circuit should be indicated in both cases for a good rotor.
  - e. If the windings are defective or physical damage cannot be corrected, replace the rotor assembly.
9. Use a commercial capacitor checker to test the capacitor for capacity, shorts, leakage, and series resistance.

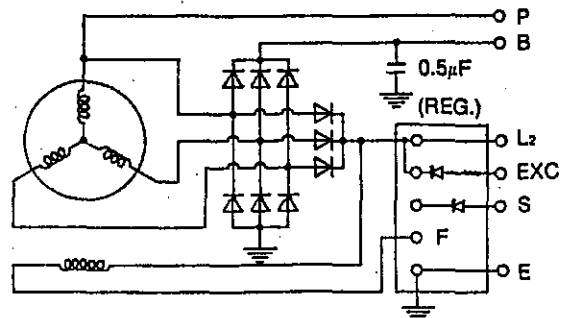

INTERNAL CIRCUIT WIRING

# MANDO ALTERNATOR SERVICE

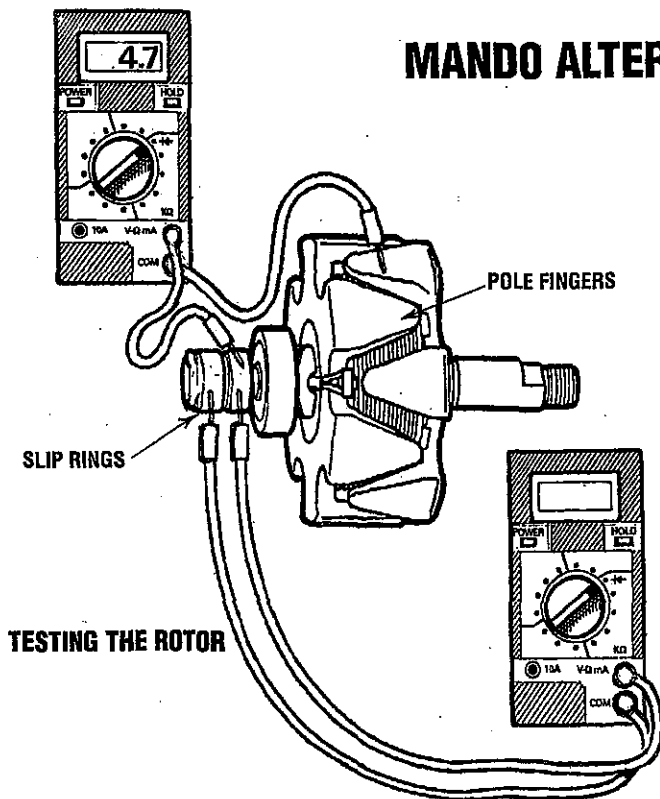

2. Place the rotor (pulley end up) on the bed of an arbor press, on two steel blocks.
3. Press the front housing and bearing assembly down onto the rotor shaft. Press against the bearing's inner race only, using a sleeve driver. Take care to insure that the rotor leads clear the steel blocks.

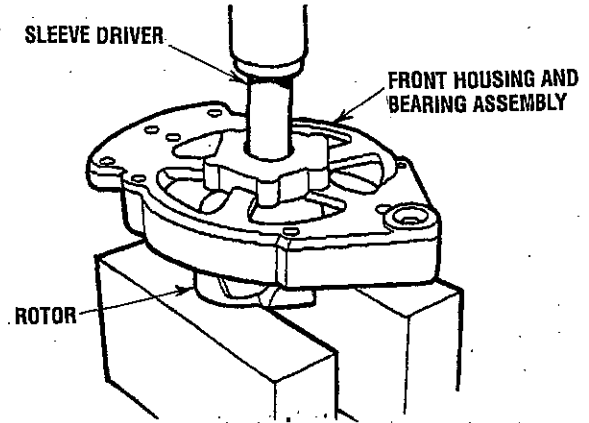

## INSTALLING THE FRONT HOUSING ON THE ROTOR ASSEMBLY

## ASSEMBLE ALTERNATOR

1. Carefully press the front bearing into the front housing, pushing against the bearing's outer race using a bearing driver. Lock the bearing in place with screws.  
TORQUE: 25 - 35 lb-in (2.8 - 4.0 Nm)

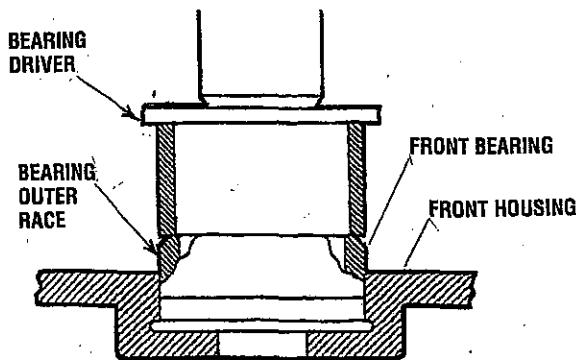

## FRONT BEARING ASSEMBLY

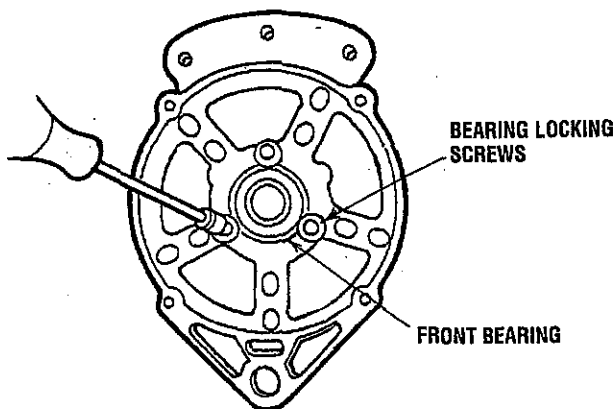

## ASSEMBLING THE BEARINGS

4. Install the rectifier assembly into the rear housing.
5. Insert the Phillips screw and tighten it.

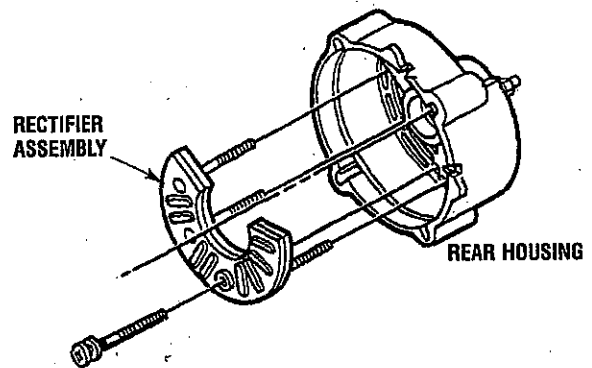

6. Assemble the front and rear housings as follows:
  - a. Put the stator winding in the front housing with the stator leads away from the front housing and the notches in the stator laminations aligned with the four through-bolt holes in the housing.
  - b. Align the scribe marks you made in the stator, and front and rear housings during disassembly.
  - c. Slip the rear housing into place over the rotor shaft. Align the mounting holes and put the stator leads through the holes at the top of the rear housing.
  - d. Install the four bolts and tighten them.  
TORQUE: 35 - 65 lb-ft (4.0 - 7.3 Nm)

**NOTE:** If the front housing is new, the through-bolt will not be tapped.

# MANDO ALTERNATOR SERVICE

7. Install the spacer and the fan. Then push the pulley, lockwasher and nut onto the shaft. Turn the nut a few turns.
8. Place an oversized V-belt around the pulley and fasten the pulley in a vise.

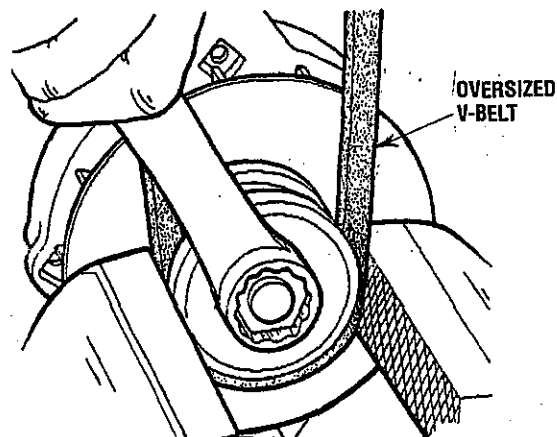

**INSTALLING THE PULLEY AND THE FAN NUT**

9. Use a torque wrench to tighten the nut.  
*TORQUE: 35 - 50 lb-ft (47 - 68 Nm)*
10. Carefully install the brush/regulator assembly on the rear housing with the two mounting screws.
11. Install the small terminal insulators.
12. Install the large terminal insulator.
13. Install the jumper.
14. Install the nut on the terminal.
15. Install the brush/regulator assembly cover.
16. Install the Phillips screw for the brush/regulator assembly cover.  
*TORQUE: 25 - 35 lb-ft (2.8 - 5.1 Nm)*
17. Install the capacitor.
18. Install the terminal nuts.
19. Install the jumper.
20. Install the last terminal nut.

## INSTALL ALTERNATOR

1. Install the alternator, screws and washers.
2. Connect the wiring leads.
3. Put the belt on the alternator, crankshaft and coolant pump pulleys.
4. Adjust the alternator belt's tension (see *DRIVE BELT ADJUSTMENT* under *ENGINE ADJUSTMENTS*).

### MANDO ALTERNATOR SPECIFICATIONS

Battery Voltage	12 Volt
Maximum Speed	13500 RPM
Cut in Speed	Max. 2000 RPM (at exc.) Max. 1500 RPM (at L2)
Reg. Set Voltage	14.7 Volts
Ambient Temp.	-20°C - 100°C
Ground	Negative

# GENERATOR WIRING DIAGRAM

#44735

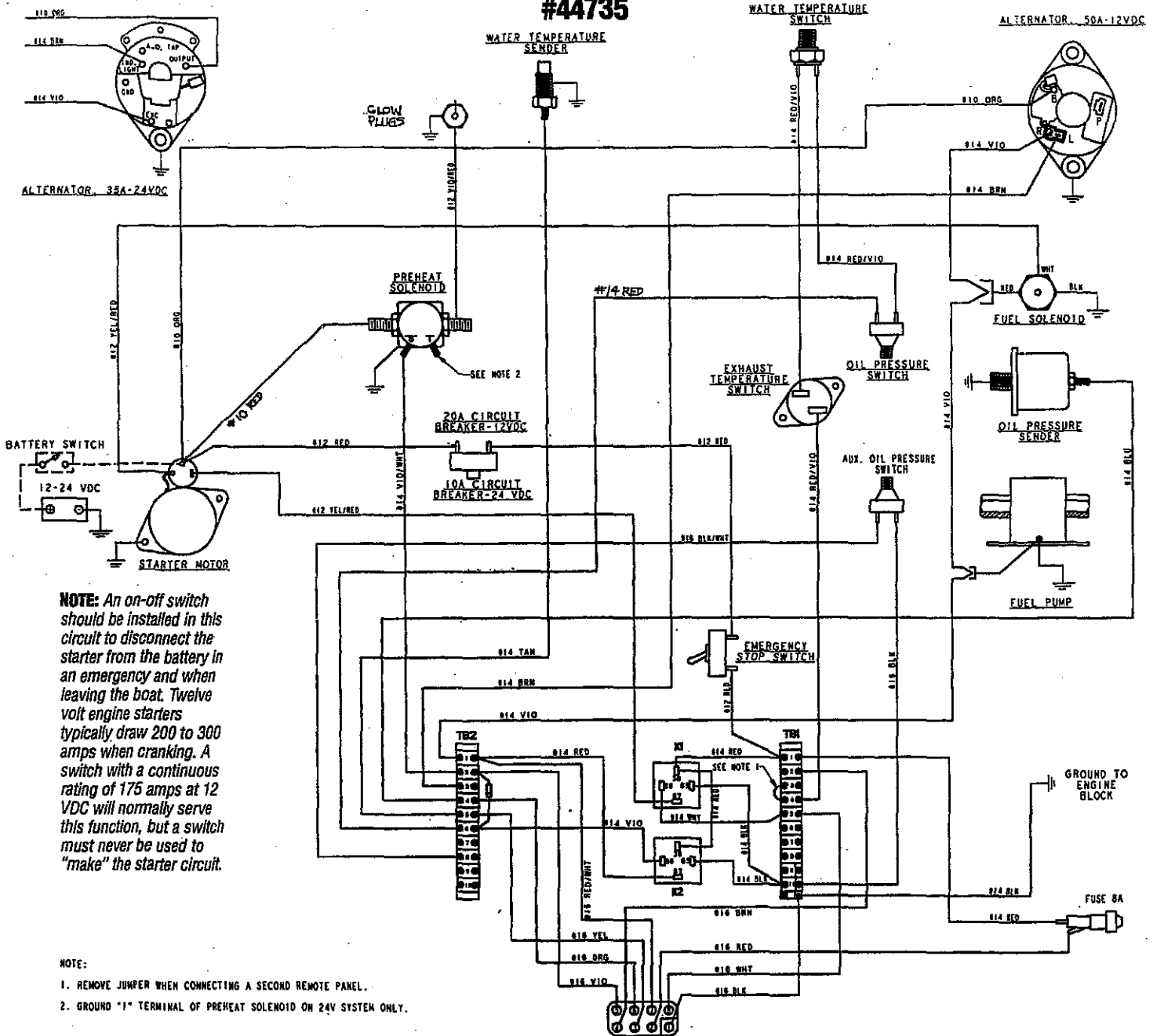

**NOTE:** An on-off switch should be installed in this circuit to disconnect the starter from the battery in an emergency and when leaving the boat. Twelve volt engine starters typically draw 200 to 300 amps when cranking. A switch with a continuous rating of 175 amps at 12 VDC will normally serve this function, but a switch must never be used to "make" the starter circuit.

- NOTE:
1. REMOVE JUMPER WHEN CONNECTING A SECOND REMOTE PANEL.
  2. GROUND "1" TERMINAL OF PREHEAT SOLENOID ON 24V SYSTEM ONLY.

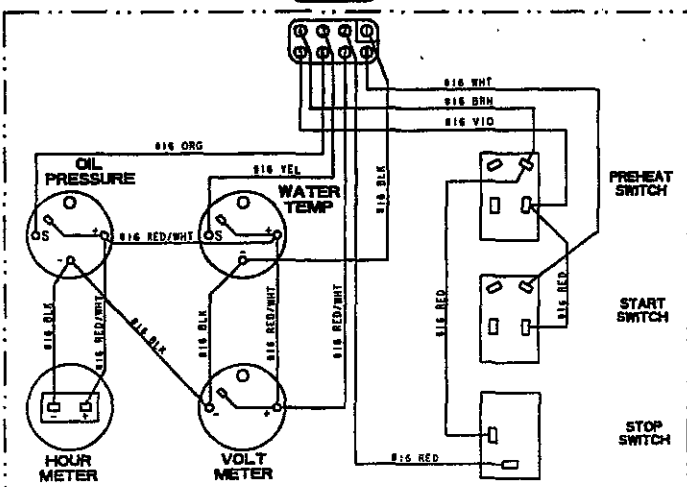
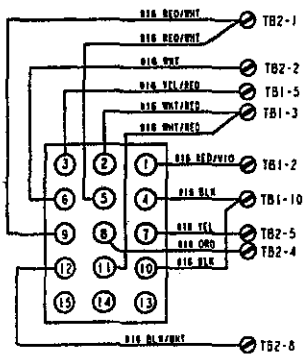

# GENERATOR WIRING SCHEMATIC

## #44735

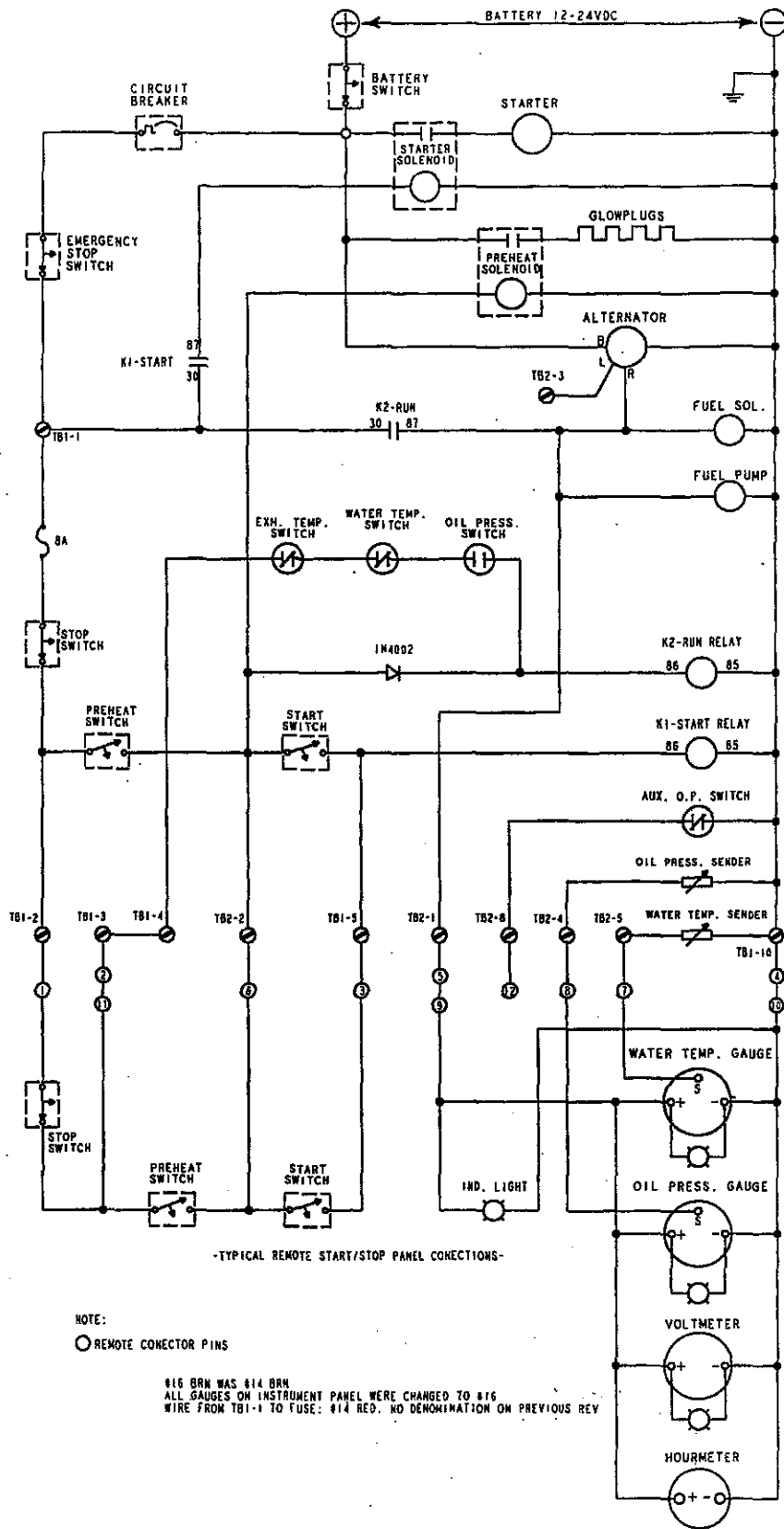

-TYPICAL REMOTE START/STOP PANEL CONNECTIONS-

NOTE:  
 ○ REMOTE CONNECTOR PINS

#16 BRN WAS #14 BRN  
 ALL GAUGES ON INSTRUMENT PANEL WERE CHANGED TO #16  
 WIRE FROM TBI-1 TO FUSE: #14 RED, NO DENOMINATION ON PREVIOUS REV

# REMOTE INSTRUMENT PANEL

#44329

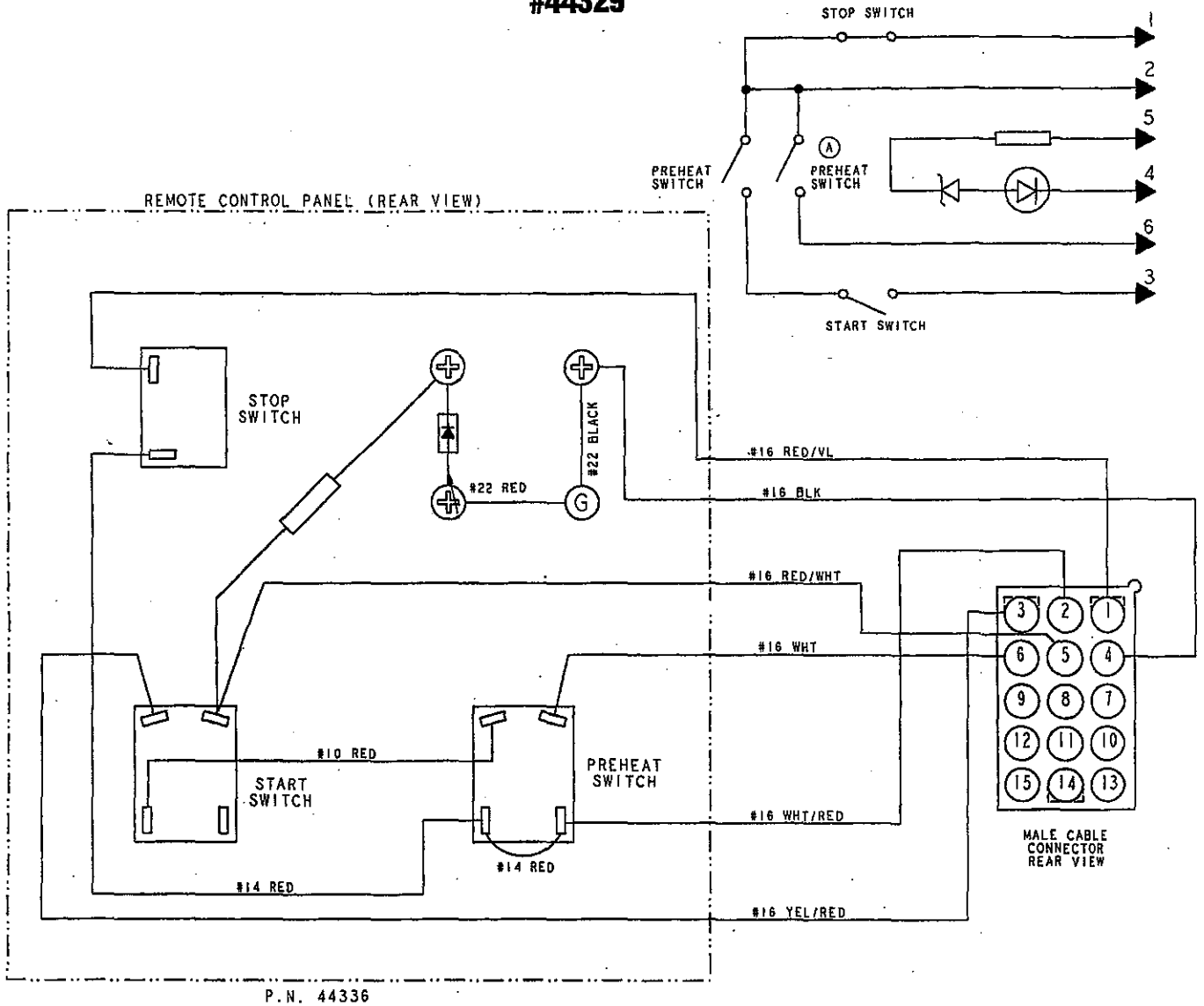

# SPECIFICATIONS - 11.5BTD, 12.6BTD, 10.0BTDA, 8.0BTDA

## GENERAL

Engine Type	Diesel, four-cycle, three-cylinder, fresh water-cooled, vertical in-line overhead valve mechanism.	
Displacement	80.4 cubic inches (1.318 liter)	
Aspiration	Naturally aspirated.	
Combustion Chamber	Swirl type.	
Bore & Stroke	3.07 x 3.62 inches (78 x 92 mm)	
Firing Order	1 - 3 - 2	
Direction of Rotation	Clockwise, when viewed from the front.	
Compression Ratio	22:1	
Weight (Engine Only)	8.0 BTDA	467 lbs (211.8 kilos).
	10.0 BTDA	513 lbs (232.7 kilos)
	12.5 BTDA	513 lbs (232.7 kilos)
Inclination	Continuous 15° Temporary 25° (not to exceed 30 min.)	
Engine Combustion Air Requirements at 60 Hz 1800rpm	41 cfm (1.16 cmm)	

## TUNE-UP SPECIFICATIONS

Compression Pressure Minimum	427 psi (30 kg/cm <sup>2</sup> ) at 280 rpm 384 psi (27 kg/cm <sup>2</sup> )	
Spilled Timing (Static)	17° (spill)	
Valve Seat Angle	45°	
Engine Timing	17° BTDC	
Injector Pressure	1991 + 71 - 0 psi (140 + 5 - 0 kgf/cm <sup>2</sup> ).	
Valve Seat Angle	Intake 45° Exhaust 30°	
Valve Clearance (engine cold)	0.25mm (0.0098 inches)	

## LUBRICATION SYSTEM

General	Pressure fed system.	
Oil Filter	Full flow, paper element, spin-on type.	
Sump Capacity (not including filter)	3.9 U.S. qts (3.7 liters)	
Operating Oil Pressure (engine hot)	50 - 60 psi (3.5 - 4.2 kg/cm <sup>2</sup> )	
Oil Grade	API Specification CF or CG-4, SAE 30, 10W-30, 15W-40	

## FUEL SYSTEM

General	Open flow, self priming.	
Fuel	No. 2 diesel oil (cetane rating of 45 or higher).	
Fuel Injection Pump	In-line plunger type (BOSCH).	
Nozzle	Throttle type.	
Fuel Filter	Cartridge Type (PN#030200). Inlet Fuel Filter PN#048076)	
Air Cleaner	Replaceable paper filter cartridge.	
Fuel Lift Pump	12 volt DC lift capacity of 5' (1.5 mm) solid state	

## ELECTRICAL SYSTEM

Starting Battery	12 Volt, (-) negative ground	
Battery Capacity	600 - 800 Cold Cranking Amps (CCA)	
DC Charging Alternator	51 Amp rated, belt-driven	
Starting Aid	Glow plugs, sheathed type	
Starter	12 Volt, reduction gear	
Cold Cranking Amp Drain	175 amps (approximate)	

## COOLING SYSTEM

General	Fresh water-cooled block, thermostatically-controlled with heat exchanger.	
Operating Temperature	170 - 190° F (77 - 88° C)	
Fresh Water Pump	Centrifugal type, metal impeller, belt-driven.	
Raw Water Pump	Positive displacement, rubber impeller, belt driven	
Raw Water Flow at 1800 rpm (Measures before discharging into exhaust elbow)	7-8 gpm (25.9 - 29.6 gpm)	
System Capacity (Fresh Water)	5.0 US qts (4.7 liters)	



# SPECIFICATIONS 8.0KW BTDA

AC GENERATOR (Single Phase)	
Single Phase	Brushless, four-pole, revolving field. Pre-lubricated, single-bearing design. Reconnectable, single-phase transformer regulation (optional solid-state voltage regulation).
Voltage	120 or 120/240 Volts - 60 Hertz 230 Volts - 50 Hertz.
Voltage regulation:	±5% no load to full load.
Frequency regulation:	.5 Hertz (.60%) no load to full load.
Rating (Volts AC)	
<b>60 Hertz (1800 rpm)</b>	120 Volts      66 Amps
<b>8.0 KW</b>	120/240 Volts    66/33 Amps
<b>50 Hertz (1500 rpm)</b>	220 Volts      27 Amps
<b>6.0 KW</b>	
Generator Cooling Air Requirements (60 Hertz) at 1800 rpm	175 - 200 cfm (4.95 - 5.66 cmm) <b>NOTE: Increase air supply 15% for 50 Hertz operation (1500 rpm).</b>
Engine Combustion Air Requirements (60 Hertz) at 1800 rpm	42 cfm (1.19 cmm)
Engine Compartment Cooling Air	100 - 200 cfm (2.83 - 5.66 cmm)
Generator Compartment Ambient Temperature Recommendations	122°F (50°C) maximum <b>NOTE: Forced ventilation should be provided to maintain generator compartment temperatures below 122°F (50°C).</b>

# SPECIFICATIONS 10.0 BTDA

AC GENERATOR (Single Phase)	
Single Phase	Brushless, four-pole, revolving field. Pre-lubricated, single-bearing design. Reconnectable, single-phase transformer regulation (optional solid-state voltage regulation).
Voltage	120 or 120/240 Volts - 60 Hertz 230 Volts - 50 Hertz.
Voltage regulation:	±5% no load to full load.
Frequency regulation:	.5 Hertz (.60%) no load to full load.
Rating (Volts AC)	
<b>60 Hertz (1800 rpm)</b>	120 Volts      83.3 Amps
<b>10.0 KW</b>	120/240 Volts    83.3/41.6 Amps
<b>50 Hertz (1500 rpm)</b>	220 Volts      32.6 Amps
<b>7.5 KW</b>	
Generator Cooling Air Requirements (60 Hertz) at 1800 rpm	225 - 250 cfm (5.66 - 6.37 cmm) <b>NOTE: Increase air supply 15% for 50 Hertz operation (1500 rpm).</b>
Engine Combustion Air Requirements	42 cfm (1.19 cmm)
Generator Compartment Ambient Temperature Recommendations	122°F (50°C) maximum <b>NOTE: Forced ventilation should be provided to maintain generator compartment temperatures below 122°F (50°C)</b>

AC GENERATOR (3 Phase)		
Three Phase	Brushless, six-pole, revolving field. Sealed lubricated, single-bearing design. 12 Lead reconnectable for low voltage WYE, high voltage Delta. Solid state voltage regulator with protection circuitry	
<b>10.0 KW - 60 Hz</b>		
<b>7.5 KW - 50 Hz</b>		
Voltage - 3 phase (60 Hertz)	Low Voltage WYE	240 Volts
	High Voltage WYE	480 Volts
	DELTA	240 Volts
Voltage - 3 Phase (50 Hertz)	High Voltage WYE	380 Volts
	DELTA	220 Volts
Amperage - 3 phase (60 Hertz)	Low Voltage WYE	35 Amps
	High Voltage WYE	15 Amps
	DELTA	30 Amps
Amperage - 3 phase (50 Hertz)	High Voltage WYE	14 Amps
	DELTA	24 Amps
Engine Combustion Air Requirements (60 Hertz) at 1800 rpm	42 cfm (1.19 cmm)	
Engine Compartment Cooling Air	100 - 200 cfm (2.83 - 5.66 cmm)	
Generator Compartment Ambient Temperature Recommendations	122°F (50°C) maximum <b>NOTE: Forced ventilation should be provided to maintain generator compartment temperatures below 122°F (50°C)</b>	

# SPECIFICATIONS 12.5KW BTDB AND 15.0KW BTDC

## GENERAL

Engine Type	Diesel, four-cycle, four-cylinder, fresh water-cooled, vertical in-line overhead valve mechanism.
Displacement	107.3 cubic inches (1.758 liter)
Aspiration	Naturally aspirated.
Combustion Chamber	Swirl type.
Bore & Stroke	3.07 x 3.62 inches (78 x 92 mm)
Firing Order	1 - 3 - 4 - 2
Direction of Rotation	Clockwise, when viewed from the front.
Compression Ratio	22:1
Dimensions - inches (mm) Engine Only	Height: 24.0 inches (609.6 mm) Width: 19.0 inches (482.6 mm) Length: 34.6 inches (878.8 mm)
Weight (dry)	569 lbs (258.10 kgs)
Fuel Consumption	1.42 g/hr (5.38 ltr/hr) at 1800 rpm (15Kw) 1.19 g/hr (4.50 ltr/hr) at 1800 rpm (12.5Kw)
HP @ 1800 RPM	25 HP
HP @ 1500 RPM	21 HP

## TUNE-UP SPECIFICATIONS

Compression Pressure Minimum	427 psi (30 kg/cm <sup>2</sup> ) at 280 rpm 384 psi (27 kg/cm <sup>2</sup> )
Spilled Timing (Static)	17° (spill) BTDC
Valve Seat Angle	Intake 45° Exhaust 30°
Engine Speed	1800 rpm (60Hz) 1500 rpm (50Hz)
Valve Clearance	0.25 inches (0.0098 mm)
Injector Pressure	1991 + 71 - 0 psi (140 + 5 - 0 kgf/cm <sup>2</sup> ).
Engine Timing	17° BTDC

## ELECTRICAL SYSTEM

Starting Battery	12 Volt, (-) negative ground
Battery Capacity	800 - 1000 Cold Cranking Amps (CCA)
DC Charging Alternator	50 Amp rated, belt-driven
Starting Aid	Glow plugs, sheathed type
Starter	12 Volt, reduction gear
Cold Cranking Amp Draw	175 - 200 amps (approx.)

## FUEL SYSTEM

General	Open flow, self priming.
Fuel	No. 2 diesel oil (cetane rating of 45 or higher).
Fuel Injection Pump	In-line plunger type (BOSCH).
Nozzle	Throttle type.
Fuel Filter	Cartridge Type (PN#030200). Inlet Fuel Filter PN#048076
Air cleaner	Replaceable paper filter cartridge.
Fuel Lift Pump	12 volt DC lift capacity of 5' (1.5 mm) wet

## COOLING SYSTEM

General	Fresh water-cooled block, thermostatically-controlled with heat exchanger.
Operating Temperature	170 - 190° F (77 - 88° C)
Fresh Water Pump	Centrifugal type, metal impeller, belt-driven.
Raw Water Pump	Positive displacement, rubber impeller, belt driven
System Capacity (Fresh Water)	8.0 US qts (7.6 liters)
Raw Water Flow at 1800 rpm (Measures before discharging into exhaust elbow)	7-8 gpm (25.9 - 29.6 gpm)
Engine Combustion Air Requirements at 60 Hz 1800rpm	56 cfm (1.60 cmm)

## LUBRICATION SYSTEM

General	Pressure fed system.
Oil Filter	Full flow, paper element, spin-on type.
Sump Capacity (not including filter)	4.5 U.S. qts (4.3 liters)
Operating Oil Pressure (engine hot)	50 - 60 psi (3.5 - 4.2 kg/cm <sup>2</sup> )
Oil Grade	API Specification CF or CG-4, SAE 30, 10W-30, 15W-40

# SPECIFICATIONS 11.5KW BTD

AC GENERATOR (Single Phase)	
Single Phase	Brushless, four pole, revolving field. Pre-lubricated, single bearing design. Reconnectable, single phase transformer regulation (optional solid state voltage regulator)
Voltage	120 or 120/240 volts - 60 hertz 230 Volts - 50 Hertz
Voltage Regulation	± 5% no load to full load.
Frequency Regulation	.3 Hertz (.5%) no load to full load.
Rating (Volts AC)	
<b>60 Hz (1800 rpm)</b>	120 volts      95.8 amps
<b>11.5 KW</b>	120/240 volts    95.8/47.9 amps
<b>50 Hz (1500 rpm)</b>	230 volts      40 amps
<b>9.2 KW</b>	
Generator Cooling Air requirements (60 Hz) at 1800 rpm	225 - 250 cfm (5.66 - 6.37 cmm) <b>NOTE: Increase air supply 15% for 50 Hertz operation (1500 rpm)</b>
Generator Compartment Ambient Temperature Recommendations	104°F (40°C) maximum <b>NOTE: Forced ventilation should be provided to maintain generator compartment temperatures below 104°F (40°C).</b>

AC GENERATOR (3 Phase)		
Three Phase	Brushless, six-pole, revolving field. Sealed lubricated, single-bearing design. 12 Lead reconnectable for low voltage WYE, high voltage Delta. Solid state voltage regulator with protection circuitry	
<b>11.5 KW - 60 Hertz</b>		
<b>9.2 KW - 50 Hertz</b>		
Voltage - 3 phase (60 Hertz)	Low Voltage WYE	240 Volts
	High Voltage WYE	480 Volts
	DELTA	240 Volts
Voltage - 3 Phase (50 Hertz)	High Voltage WYE	400 Volts
	DELTA	230 Volts
Amperage - 3 phase (60 Hertz)	Low Voltage WYE	34 Amps
	High Voltage WYE	17 Amps
	DELTA	34 Amps
Amperage - 3 phase (50 Hertz)	High Voltage WYE	16 Amps
	DELTA	29 Amps
Generator Cooling Air requirements (60 Hz) at 1800 rpm	225 - 250 cfm (5.66 - 6.37 cmm) <b>NOTE: Increase air supply 15% for 50 Hertz operation (1500 rpm)</b>	
Generator Compartment Ambient Temperature Recommendations	104°F (40°C) maximum <b>NOTE: Forced ventilation should be provided to maintain generator compartment temperatures below 104°F (40°C).</b>	

# SPECIFICATIONS 12.6KW BTD

AC GENERATOR (Single Phase)	
Single Phase	Brushless, four pole, revolving field. Pre-lubricated, single bearing design. Reconnectable, single phase transformer regulation (optional solid state voltage regulator)
Voltage	120 or 120/240 volts - 60 hertz 230 Volts - 50 Hertz
Voltage Regulation	± 5% no load to full load.
Frequency Regulation	.3 Hertz (.5%) no load to full load.
Rating (Volts AC)	
<b>60 Hz (1800 rpm)</b>	120 volts      95.8 amps
<b>12.6 KW</b>	120/240 volts    195.8/49.9 amps
<b>50 Hz (1500 rpm)</b>	230 volts      40 amps
<b>10.4 KW</b>	
Generator Cooling Air requirements (60 Hz) at 1800 rpm	225 - 250 cfm (5.66 - 6.37 cmm) <b>NOTE: Increase air supply 15% for 50 Hertz operation (1500 rpm)</b>
Generator Compartment Ambient Temperature Recommendations	104°F (40°C) maximum <b>NOTE: Forced ventilation should be provided to maintain generator compartment temperatures below 104°F (40°C).</b>

AC GENERATOR (3 Phase)		
Three Phase	Brushless, six-pole, revolving field. Sealed lubricated, single-bearing design. 12 Lead reconnectable for low voltage WYE, high voltage Delta. Solid state voltage regulator with protection circuitry	
<b>12.5 KW - 60 Hertz</b>		
<b>10.4 KW - 50 Hertz</b>		
Voltage - 3 phase (60 Hertz)	Low Voltage WYE	240 Volts
	High Voltage WYE	480 Volts
	DELTA	240 Volts
Voltage - 3 Phase (50 Hertz)	High Voltage WYE	400 Volts
	DELTA	230 Volts
Amperage - 3 phase (60 Hertz)	Low Voltage WYE	38 Amps
	High Voltage WYE	19 Amps
	DELTA	38 Amps
Amperage - 3 phase (50 Hertz)	High Voltage WYE	18 Amps
	DELTA	32 Amps
Generator Cooling Air requirements (60 Hz) at 1800 rpm	225 - 250 cfm (5.66 - 6.37 cmm) <b>NOTE: Increase air supply 15% for 50 Hertz operation (1500 rpm)</b>	
Generator Compartment Ambient Temperature Recommendations	104°F (40°C) maximum <b>NOTE: Forced ventilation should be provided to maintain generator compartment temperatures below 104°F (40°C).</b>	

## SPECIFICATIONS 12.5KW BTDB

AC GENERATOR (Single Phase)	
Single Phase	Brushless, four pole, revolving field. Pre-lubricated, single bearing design. Reconnectable, single phase transformer regulation (optional solid state voltage regulator)
Voltage	120 or 120/240 volts - 60 hertz 230 Volts - 50 Hertz
Voltage Regulation	±5% no load to full load.
Frequency Regulation	3 Hertz (.5%) no load to full load.
Rating (Volts AC)	
<b>60 Hz (1800 rpm)</b>	120 volts      104 amps 120/240 volts    104/52 amps
<b>12.5 KW</b>	
<b>50 Hz (1500 rpm)</b>	230 volts      40.0 amps
<b>9.3 KW</b>	
Generator Cooling	225 - 250 cfm (6.37 - 7.08 cmm) Air requirements (60 Hz) at 1800 rpm
<b>NOTE:</b>	<i>Increase air supply 15% for 50 Hertz operation (1500 rpm)</i>
Generator Compartment Ambient Temperature Recommendations	122°F (50°C) maximum <b>NOTE:</b> <i>Forced ventilation should be provided to maintain generator compartment temperatures below 122°F (50°C).</i>

AC GENERATOR (3 Phase)		
General - 3 Phase	Brushless, six-pole, revolving field. Sealed lubricated, single-bearing design. 12 Lead reconnectable for low voltage WYE, high voltage Delta. Solid state voltage regulator with protection circuitry	
<b>12.5 Kw - 60 Hertz</b>		
<b>9.3 Kw - 50 Hertz</b>		
Voltage - 3 phase (60 Hertz)	Low Voltage WYE	208 Volts
	High Voltage WYE	480 Volts
	DELTA	240 Volts
Voltage - 3 Phase (50 Hertz)	High Voltage WYE	380 Volts
	DELTA	230 Volts
Amperage - 3 phase (60 Hertz)	Low Voltage WYE	43 Amps
	High Voltage WYE	18 Amps
	DELTA	37 Amps
Amperage - 3 phase (50 Hertz)	High Voltage WYE	17 Amps
	DELTA	30 Amps
Generator Combustion Air Requirements (60 Hertz), at 1800 rpm	56 cfm (1.6 cmm)	
Generator Compartment Ambient Temperature Recommendations	122°F (50°C) maximum <b>NOTE:</b> <i>Forced ventilation should be provided to maintain generator compartment temperatures below 122°F (50°C)</i>	

## SPECIFICATIONS 15KW BTDC

AC GENERATOR (Single Phase)	
Single Phase	Brushless, four-pole, revolving field. Pre-lubricated, single-bearing design. Reconnectable, single-phase transformer regulation (optional solid-state voltage regulation).
Voltage	120 or 120/240 Volts - 60 Hertz 230 Volts - 50 Hertz.
Voltage regulation:	±5% no load to full load.
Frequency regulation:	.3 Hertz (.60%) no load to full load. (Electronic Governed)
Rating (Volts AC)	
<b>60 Hertz (1800 rpm)</b>	120 Volts      125 Amps 120/240 Volts    125/62.5 Amps
<b>50 Hertz (1500 rpm)</b>	230 Volts      60 Amps
Generator Cooling Air Requirements (60 Hertz) at 1800 rpm	225 - 250 cfm (6.37 - 7.08 cmm) <b>NOTE:</b> <i>Increase air supply 15% for 50 Hertz operation (1500 rpm).</i>
Engine Combustion Air Requirements (60 Hertz), at 1800 rpm	56 cfm (1.6 cmm)
Generator Compartment Ambient Temperature Recommendations	122°F (50°C) maximum <b>NOTE:</b> <i>Forced ventilation should be provided to maintain generator compartment temperatures below 122°F (50°C).</i>

AC GENERATOR (3 Phase)		
General - 3 Phase	Brushless, six-pole, revolving field. Sealed lubricated, single-bearing design. 12 Lead reconnectable for low voltage WYE, high voltage Delta. Solid state voltage regulator with protection circuitry	
<b>15.0 Kw - 60 Hertz</b>		
<b>12.0 Kw - 50 Hertz</b>		
Voltage - 3 phase (60 Hertz)	Low Voltage WYE	208 Volts
	High Voltage WYE	480 Volts
	DELTA	240 Volts
Voltage - 3 Phase (50 Hertz)	High Voltage WYE	380 Volts
	DELTA	230 Volts
Amperage - 3 phase (60 Hertz)	Low Voltage WYE	52 Amps
	High Voltage WYE	22 Amps
	DELTA	45 Amps
Amperage - 3 phase (50 Hertz)	High Voltage WYE	22 Amps
	DELTA	39 Amps
Generator Compartment Ambient Temperature Recommendations	122°F (50°C) maximum <b>NOTE:</b> <i>Forced ventilation should be provided to maintain generator compartment temperatures below 122°F (50°C)</i>	

# BT GENERATOR SINGLE/THREE PHASE

This generator is a four-pole, brushless, self-excited generator which requires only the driving force of the engine to produce AC output. The copper and laminated iron in the exciter stator are responsible for the self-exciting feature of this generator. The magnetic field produced causes an AC voltage to be induced into the related exciter rotor windings during rotation. Diodes located in the exciter rotor rectify this voltage to DC and supply it to the windings of the rotating field. This creates an electromagnetic field which rotates through the windings of the main stator, inducing an AC voltage which is supplied to a load. A step down transformer is connected in parallel to the AC output of the main stator. An AC voltage is produced in the auxiliary windings of the transformer and the main stator and is, in turn, supplied to a full-wave bridge rectifier. The rectifier produces a DC voltage to further excite the exciter stator windings, enabling the generator to produce a rated AC output. An optional solid-state voltage regulator is available to work in tandem with the transformer regulator to produce a more stable AC output.

A circuit breaker is installed on all WESTERBEKE generators. This circuit breaker will automatically disconnect generator power in case of an electrical overload. The circuit breaker can be manually shut off when servicing the generator to ensure no power is coming into the boat.

**NOTE:** This circuit breaker is available as a WESTERBEKE add-on kit for earlier model generations; contact your WESTERBEKE dealer.

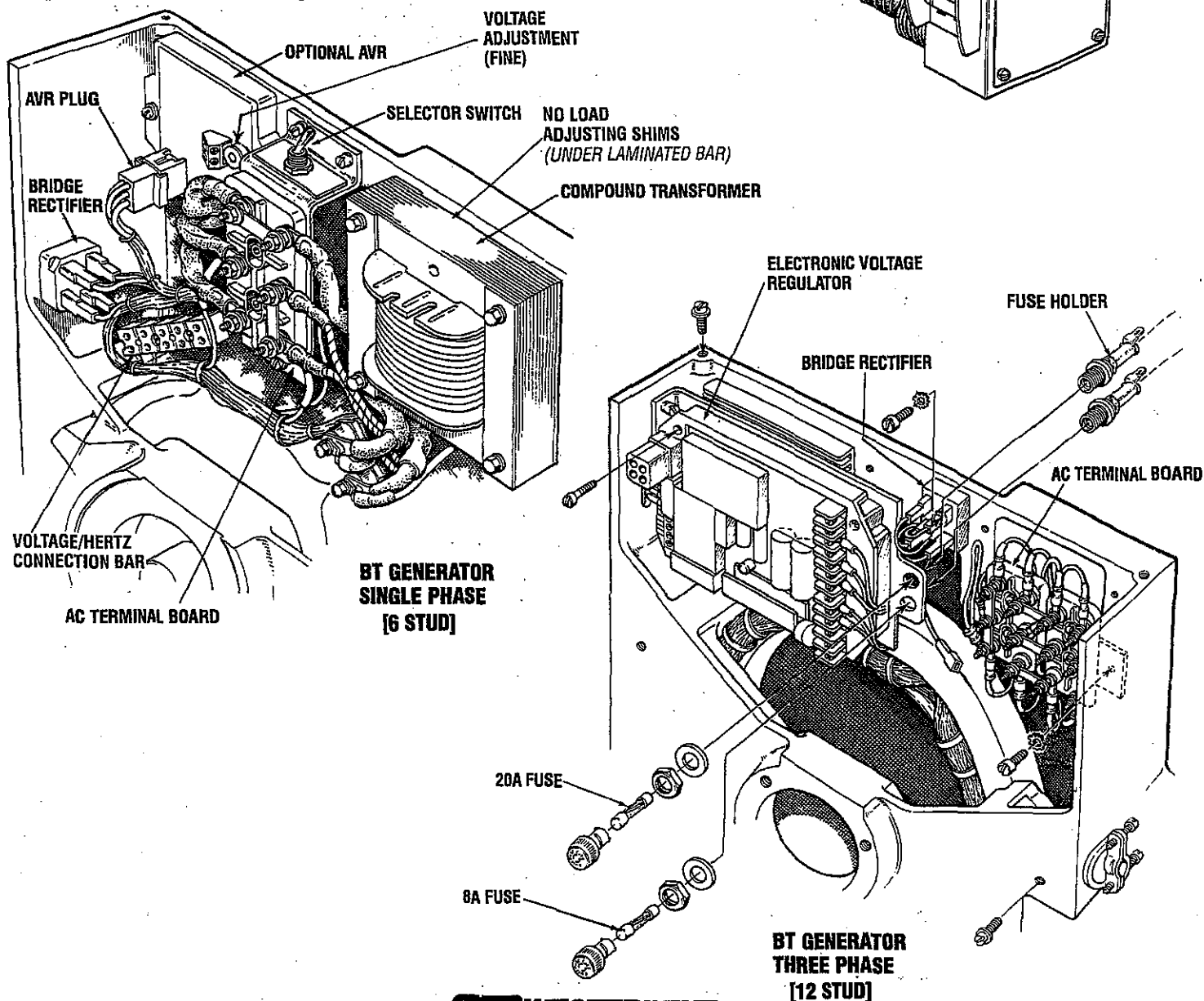

# BT GENERATOR 12 STUD INTERNAL WIRING SCHEMATIC

**NOTE:** Refer to the text and diagrams for the proper method of testing for resistance and continuity.

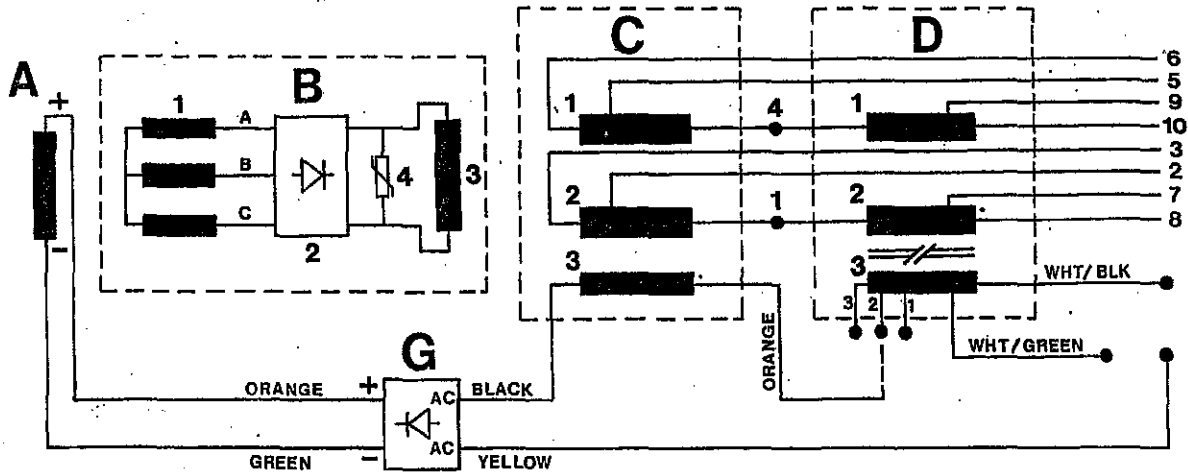

## COMPONENT RESISTANCE VALUES [OHMS]

- A** EXCITER STATOR WINDINGS \_\_\_\_\_ 10.0Ω
- B** AUXILIARY ROTOR WINDINGS (A,B,C) \_\_\_\_\_ 1.0-1.2Ω
- DIODES (6) \_\_\_\_\_ 11Ω/infinite
- ROTATING FIELD WINDINGS \_\_\_\_\_ 7.0-8.0Ω
- SUPPRESSOR \_\_\_\_\_ infinite
- C** MAIN STATOR WINDINGS \_\_\_\_\_ 20-22Ω
- MAIN STATOR AUXILIARY WINDINGS \_\_\_\_\_ 1.5-1.8Ω
- D** COMPOUND TRANSFORMER WINDINGS \_\_\_\_\_ 0.019-.021Ω
- COMPOUND TRANSFORMER  
AUXILIARY WINDINGS \_\_\_\_\_ 4.0-4.5Ω
- G** BRIDGE RECTIFIER

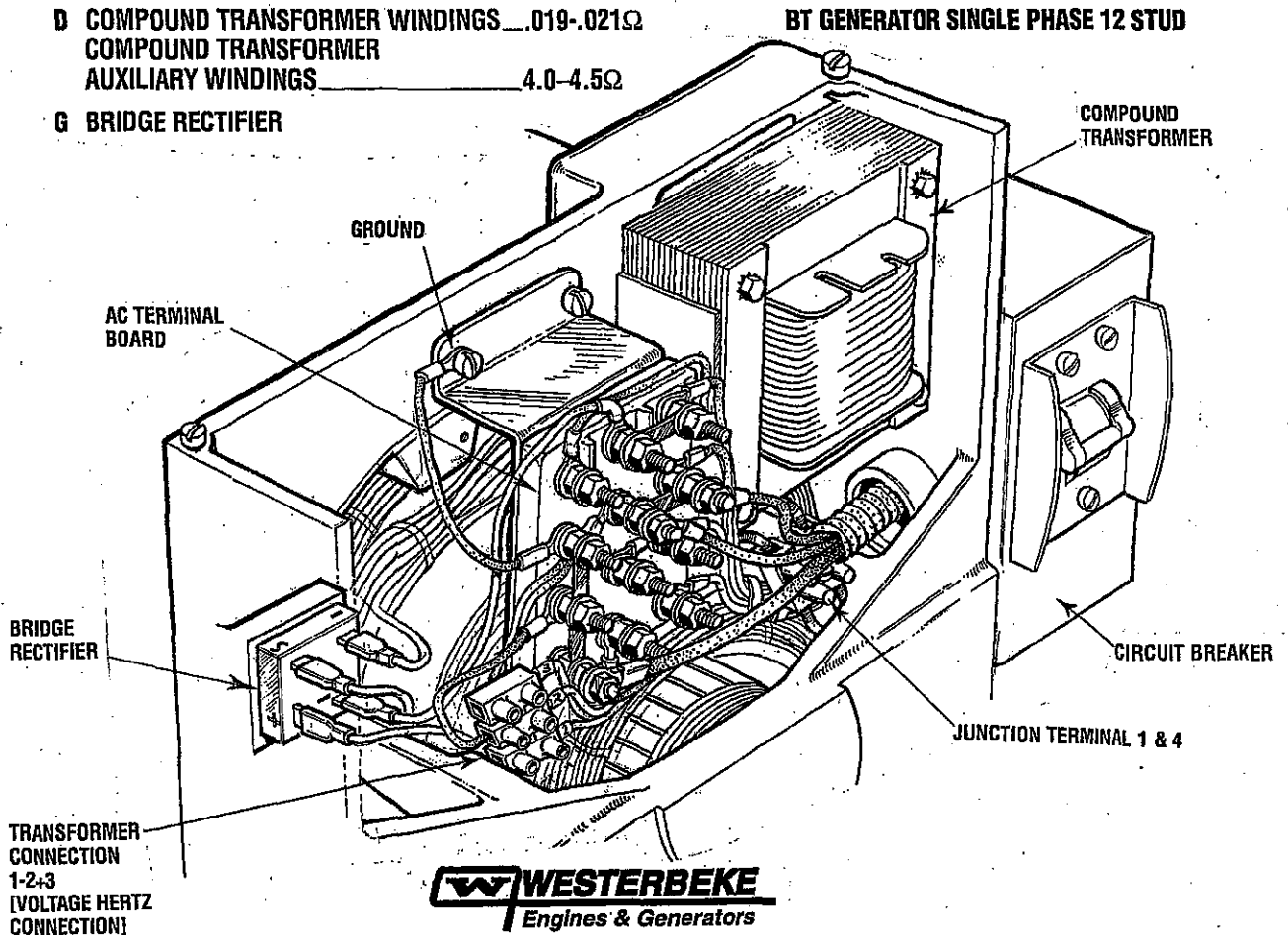

# BT GENERATOR/SINGLE PHASE 10KW-15KW GENERATORS

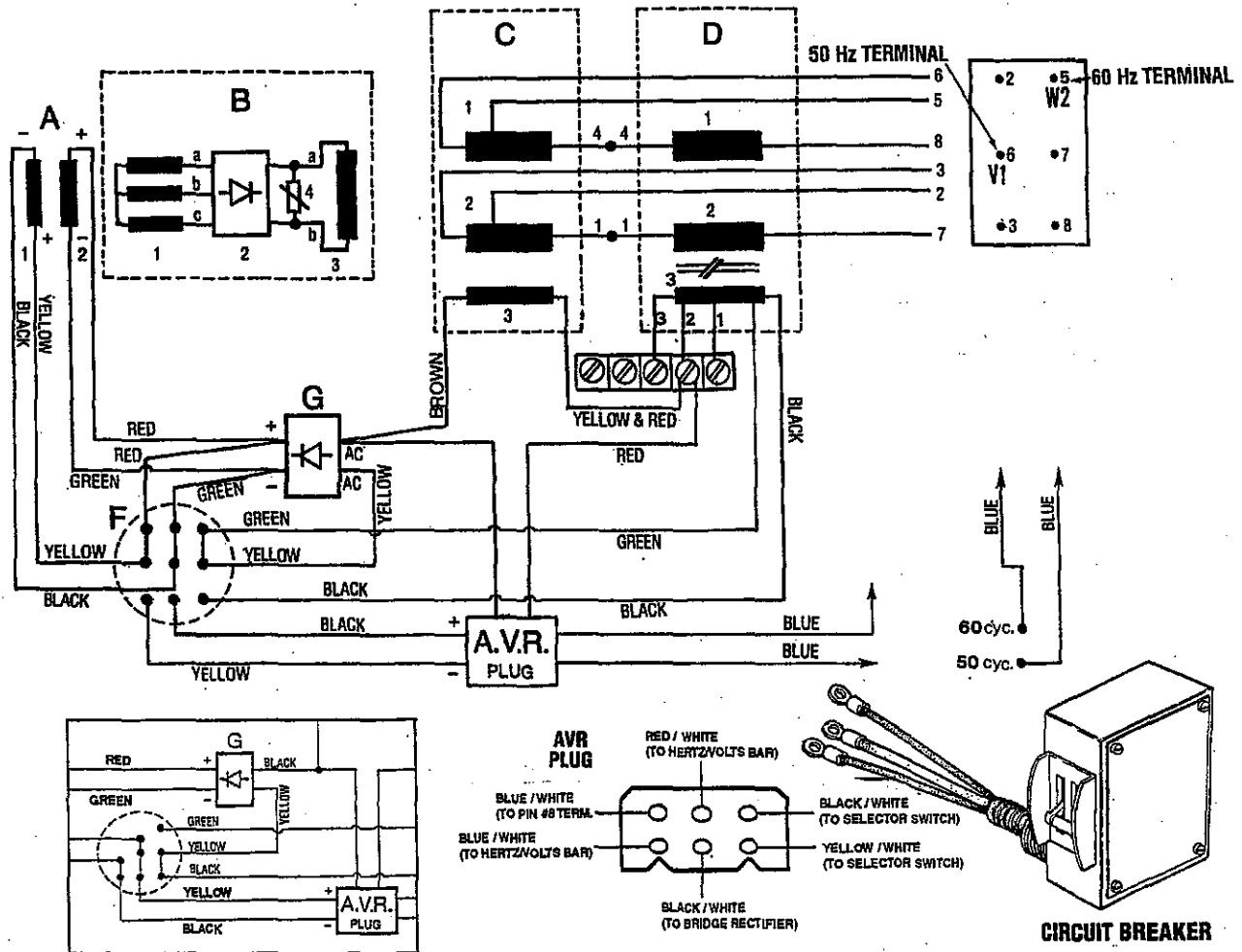

## BT GENERATOR/SINGLE PHASE 10KW-15KW GENERATORS

**A. EXCITER STATOR WINDINGS 1 & 2**  
A-1 and A-2 Exciter Stator Windings  
(Selector in **COMP** position)

**B. EXCITER ROTOR and FIELD**  
1. Auxilliary Windings (a-b-c)  
2. Diodes (6)  
3. Rotating Field Windings  
4. Suppressor

**C. MAIN STATOR**  
1. Main Stator Windings  
2. Main Stator Windings  
3. Main Stator Auxiliary Windings

**D. COMPOUND TRANSFORMER**

1. Compound Transformer Windings
2. Compound Transformer Windings
3. Compound Transformer Auxiliary Windings

Resistance readings and voltage checks can be accessed easily for the components in the exciter circuit **A**, **G**, **C-3** and **D-3** by locating the color coded wires at the connection points shown on the above schematic. When checking winding resistance values be sure to lift both of the component's electrical connections.

**G. BRIDGE RECTIFIER**

A.V.R. Optional Automatic Voltage Regulator Plug (6 Prong).

# BT GENERATOR TROUBLESHOOTING CHART

The following troubleshooting chart is designed to give insight into problems which may be encountered with the BT brushless generators operating on compound transformer regulation. Owing to the simplicity of the equipment and controls, troubleshooting is relatively easy, once the relationship between cause and effect is understood. Most potential problems are covered in the text of this manual

Keep in mind that a basic fundamental knowledge of electricity is required for this troubleshooting, and always remember that lethal voltages are present in the circuitry; therefore, extreme caution is essential when troubleshooting a generator. Only a few basic tools are necessary for diagnosis and repair.

These are hand tools: an amprobe and a quality volt-ohm-meter capable of reading less than one ohm due to the precision required in reading component winding resistances.

Before attempting any repairs, get a clear explanation of the problem as possible, preferably from an individual witnessing the problem. In some cases, this may bring to light a problem which is related to the method of operation rather than equipment fault. Bring basic repair tools with you on the initial trip to the problem equipment, such as: diodes and bridge rectifier, so that if the problem should be found in one of these easily replaceable parts, the problem can be remedied early and efficiently.

**NOTE:** When fault finding, troubleshoot components in the order indicated below.

## COMPONENT CHECKS

REFER TO THE INTERNAL WIRING DIAGRAMS

### 1. LOW VOLTAGE 60-100 VOLTS AC

- F. Selector Switch
- B. Rotor Components
  - B-2 Exciter Rotor Diodes
  - B-3 Rotor Field Windings
  - B-1 Exciteor Rotor Windings a,b, c
- A. (1-1+2) Exciter Stator Windings

### 2. RESIDUAL VOLTAGE - EXCITER CIRCUIT FAULTY

- A. (1-1+2) Exciter Stator Windings
- G. Bridge Rectifier
- D-3. Transformer Auxillary Windings
- C-3. Main Stator Auxillary Windings
- F. Selector Switch

### 3. NO AC VOLTAGE OUTPUT - MAIN STATOR/ROTOR COMPONENTS/TRANSFORMER

- C. (1+2) Exciter Stator Windings
- B-4. Suppressor
- B-2. Diodes (4-6 open/shortened)
- D. (1+2) Compound Transformer Windings
- B-3. Rotor Field Windings

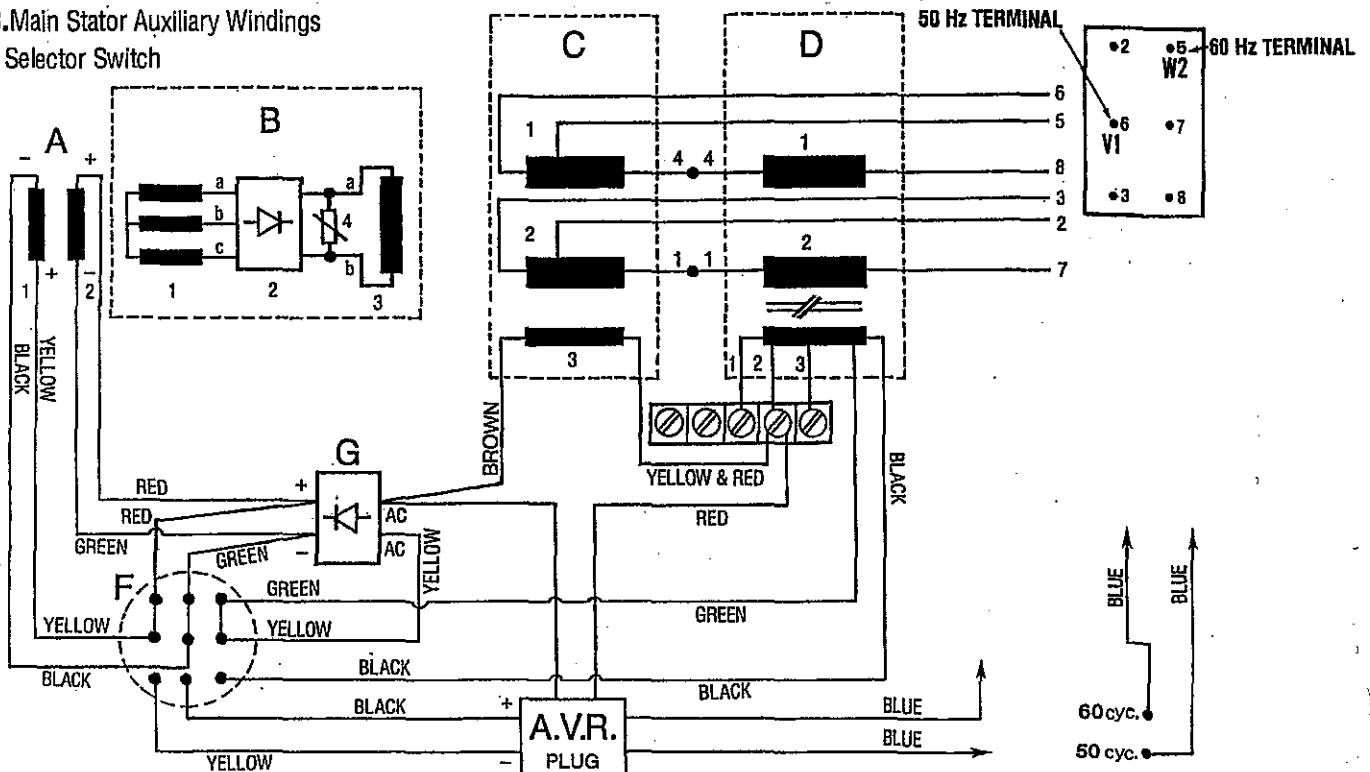



# BT GENERATOR TROUBLESHOOTING

## Testing Residual Voltage

1. The amount of no-load voltage produced by the generator can be an indicator of where in the generator the problem/fault may lie.

**Residual Voltage 10-14 volts AC (6 stud) 18-22 volts AC (12 stud)**

This voltage is the AC voltage produced by the generator from magnetism in the exciter stator field. This voltage is measured between the AC Neutral and Hot leg(s) with no-load on the generator running at 60 hertz.

The presence of residual voltage is an indication that the following generator components are OK. Refer to *INTERNAL WIRING SCHEMATICS*.

- a. Exciter Rotor (B-1 a, b, & c) & (B-2);
- b. Rotating Field (B-3);
- c. Main Stator (C-1 & C-2); and
- d. Compound Transformer (D-1 & D-2).

The fault lies in one or more of the following components in the exciter circuit:

- a. Exciter Stator (A-1 & A-2)
- b. Bridge Rectifier (G)
- c. Selector Switch (F)
- d. Main Stator Auxiliary Windings (C-3)
- e. Compound Transformer Auxiliary Winding (D-3)

2. Twelve (12) volt DC excitation of the exciter stator windings should cause the generator to produce between 140 - 150 volts AC between each hot lead and the neutral (12 volts DC is applied between the lifted (+) and (-) leads of the bridge rectifier, + to + and - to -).

Correct voltage produced with twelve volts DC excitation indicates the fault is in one or more of the above listed components **b, d** or **e**.

If the generator does not produce 140 - 150 volts AC, then include **a** and **c**.

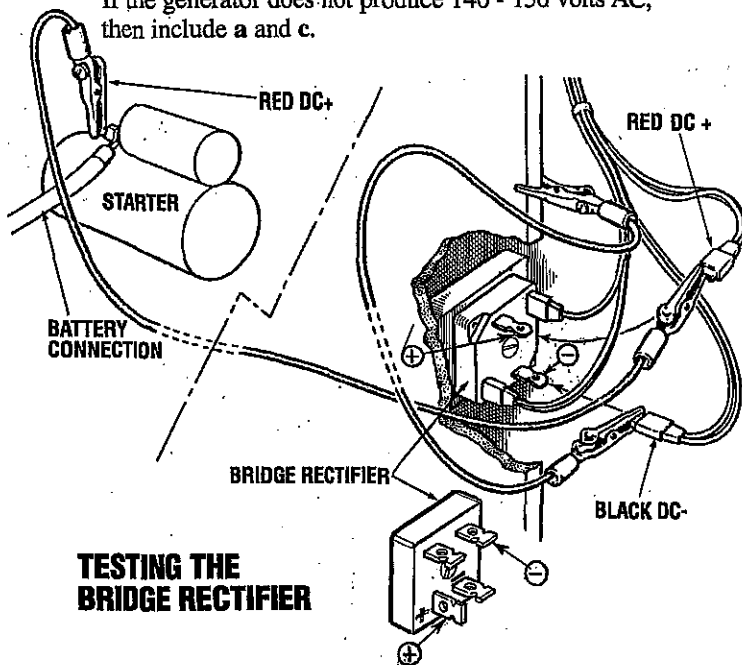

## TESTING THE BRIDGE RECTIFIER

**NOTE:** Current BT Generators use a bridge rectifier that is configured differently, connections are the same.

3. The absence of any voltage from the generator indicates a fault with the main stator windings C-1 and C-2 and/or the compound transformer windings D-1 and D-2. Apply 12 volt DC excitation to the exciter stator windings as explained in paragraph 2. A fault in the main stator and/or compound transformer windings such as a short will cause the generator engine to load down and the shorted windings to eventually produce smoke as the excitation is continued.
4. Voltage output greater than residual and less than rated output (25 - 100 volts) indicates a fault in the exciter rotor/field B-1, B-2 or B-3. Excitation of the generator as explained in paragraph 2 should produce a partial rise in voltage output and, when removed, the voltage will return to the original low output.

## BRIDGE RECTIFIER

The bridge rectifier is supplied AC voltage from the auxiliary windings in the generator stator (C-3) and the compound transformer (D-3). The AC voltage measured across the AC terminals of the rectifier during engine operation is as follows:

120 Volts N/L F/L	120/240 N/L F/L
17 - 55 volts AC	17 - 55 volts AC

Diodes in the rectifier convert this AC voltage to DC and supply it to the windings of the exciter stator to induce a field through which the exciter rotor revolves. The DC voltage measured across the (+) and (-) terminals of the bridge rectifier during engine operation is as follows:

120 Volts N/L F/L	120/240 N/L F/L
8 - 17 volts DC	8 - 17 volts DC

Failure of the bridge rectifier will result in a weak field being produced by the exciter stator windings. A weak field is present, due to the magnetism in the exciter stator, which will cause the generator to produce residual voltage.

## Testing the Bridge Rectifier for Faults with an Ohmmeter

(Meter used: *Simpson 260* at 70°F (21°C))

1. Set the ohmmeter scale on RX1 (+ DC) and set the needle to zero.
2. Connect the positive (+) lead from the ohmmeter to point #4. Taking the ohmmeter's negative (-) lead, momentarily contact points #1, #2, #3, and #5. The ohmmeter should register no deflection for any of the points touched.
3. Remove the positive (+) lead from point #4 and connect the negative (-) lead to point #4 and, with the positive (+) lead, momentarily touch points #1, #2, and #3. The ohmmeter's needle should deflect when each point is touched, showing a passage of meter voltage through the diodes in the rectifier.

# BT GENERATOR TROUBLESHOOTING/SINGLE PHASE

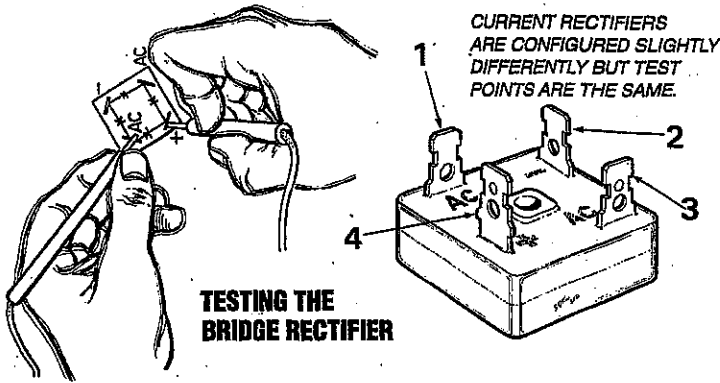

**TESTING THE BRIDGE RECTIFIER**

4. Leaving the negative (-) ohmmeter lead on point #4, touch point #5 with the positive (+) lead. No deflection of the needle should occur.
5. Place the positive (+) lead of the ohmmeter on point #1 and the negative (-) lead on point #3. The ohmmeter should not register any deflection of the needle (no deflection indicates infinite resistance). Reverse these connections and the ohmmeter should again register no deflection.

If the rectifier fails any of the previous tests (1 - 4) it is defective and should be replaced.

**NOTE:** Different style/model meters may produce opposite results from the above tests.

## Component Resistance Values

<b>A. Exciter Stator</b>	<b>B. Exciter Rotor/Field</b>
A-1 & A-2 11.5 ohm	B-1 1.05 ohm,
A-1 49.4 ohm	B-3 8.9 ohm
A-2 12.9 ohm	
<b>C. Main Stator</b>	<b>D. Compound Transformer</b>
C-1 0.089 ohm	D-1 0.007 ohm
C-2 0.089 ohm	D-2 0.007 ohm
<b>Auxiliary Windings</b>	<b>Auxiliary Windings</b>
C-3 0.85 ohm.	D-3 5.02 ohm

- E. A.C. Terminal Board
- F. Selector Switch
- G. Bridge Rectifier
- H. Optional AVR

The model code number is found stamped in the generator housing on a flat surface above the rear generator carrier bearing.

**NOTE:** These two model BT generators are used on models rated lower than the capabilities of the generator. However, the generator is rated according to the capabilities of the drive engine since horsepower produces kilowatts.

## COMPONENT RESISTANCE CHECKS

### Exciter Stator Windings

1. **Windings A-1 and A-2**  
Resistance readings for exciter windings A-1 and A-2 with the selector switch in the COMP position are taken between the positive (+) and negative (-) leads lifted off the bridge rectifier (G). Neither of these two leads should have the continuity to the generator case/ground.
2. **Winding A-1**  
Resistance readings for exciter windings A-1 with the selector switch in the ELEC position is taken between the yellow wire and the black at the A.V.R. plug (G).
3. **Winding A-2**  
Resistance readings for exciter winding A-2 with the selector switch in the ELEC position is taken between the green wire lifted off the negative (-) terminal of the bridge rectifier (G) and the red wires lifted off the positive (+) terminal of the bridge rectifier (G).

**NOTE:** The white striped wiring on earlier model generators has been changed to solid colors on current generators, the colors, however, remain the same.

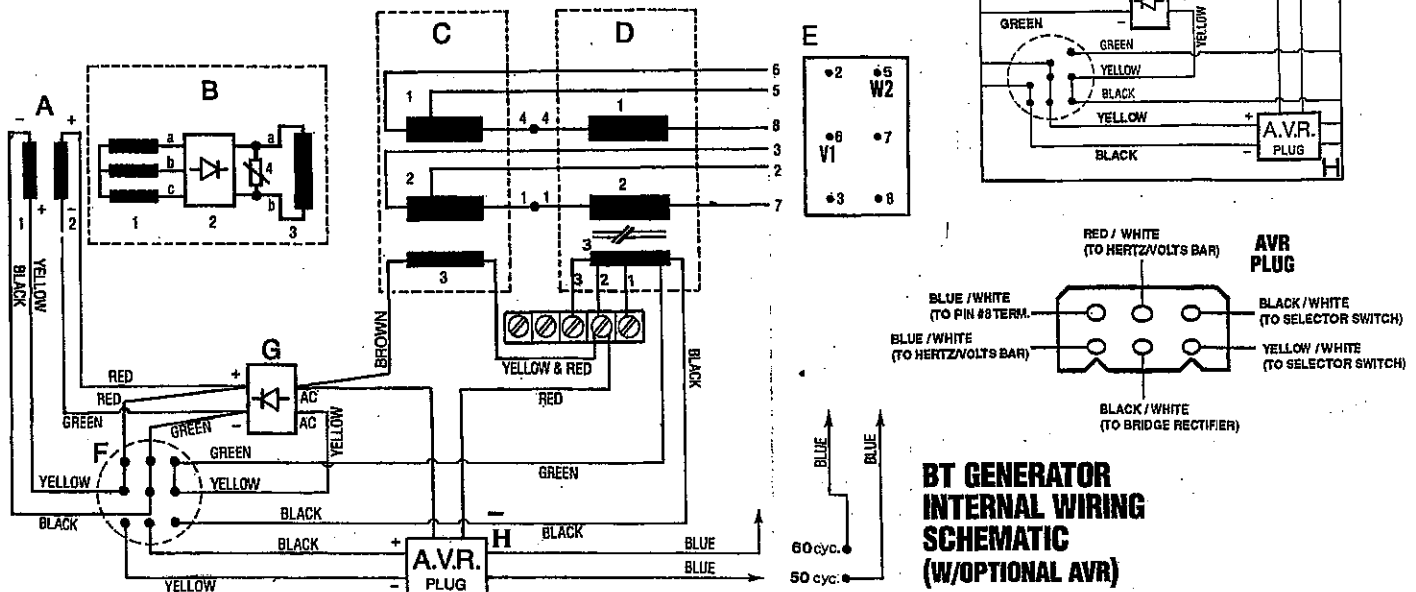

# BT GENERATOR TROUBLESHOOTING/SINGLE PHASE

## Main Stator Windings

- Group #1.** The resistance value is measured between the lifted lead #4 from the insulated terminal below the transformer and lead #6 lifted from the AC terminal block. Lead #5 should be lifted from the terminal block in order to totally isolate the stator windings of group #1.
- Group #2.** The resistance value is measured between the lifted lead #1 from the insulated terminal below the transformer and lead #3 lifted from the AC terminal block. In order to totally isolate the stator windings of group #2, lead #2 should be lifted from the terminal block.

**NOTE:** No continuity should be found between any of the lifted stator leads and the case ground or between the connections of the two groups.

- Main Stator Auxiliary Windings.** The resistance values for these windings are measured between the black double lead connection lifted off the AC terminal of the bridge rectifier (G) and the red #3 lead lifted off the Voltage/Hertz connection bar.

**NOTE:** No continuity should be found between either of these winding groups or to the generator case.

## Compound Transformer

- Group 1.** Resistance value is measured between lifted lead #4 from the red insulated terminal stud below the transformer and lead #8 lifted off the AC terminal block.
- Group 2.** Resistance value is measured between lifted lead #1 from the red insulated terminal stud below the transformer and lead #7 lifted off the AC terminal block

**NOTE:** No continuity should be found between either of these lifted leads or to the generator case/ground.

- Transformer Auxiliary Windings.** Resistance is measured between the yellow wire lifted off the AC terminal block of the bridge rectifier (G) with the selector switch in the ELEC position and the #1 red lead lifted off the Voltage/Hertz connection bar. Off this same bar, lift the #2 and #3 red leads that come from the auxiliary windings to totally isolate these windings. There should be no continuity found from either of these connections to the case/ground or to either of the transformer groups.

## Selector Switch (6 Stud BT only)

This switch is normally set in the COMP position. If an optional AVR is installed, the switch is toggled to the ELEC position.

**NOTE:** With the selector switch in ELEC position the exciter stator windings are divided, one group is excited through the bridge rectifier and the other group through the A.V.R.

## Bridge Rectifier Wiring

The illustration below shows the color coded wires at the two AC terminals and the color coded wires at the (+) and (-) DC terminals.

**NOTE:** When removing or reinstalling connections, maintain correct polarity connection on the (+) and (-) DC terminals.

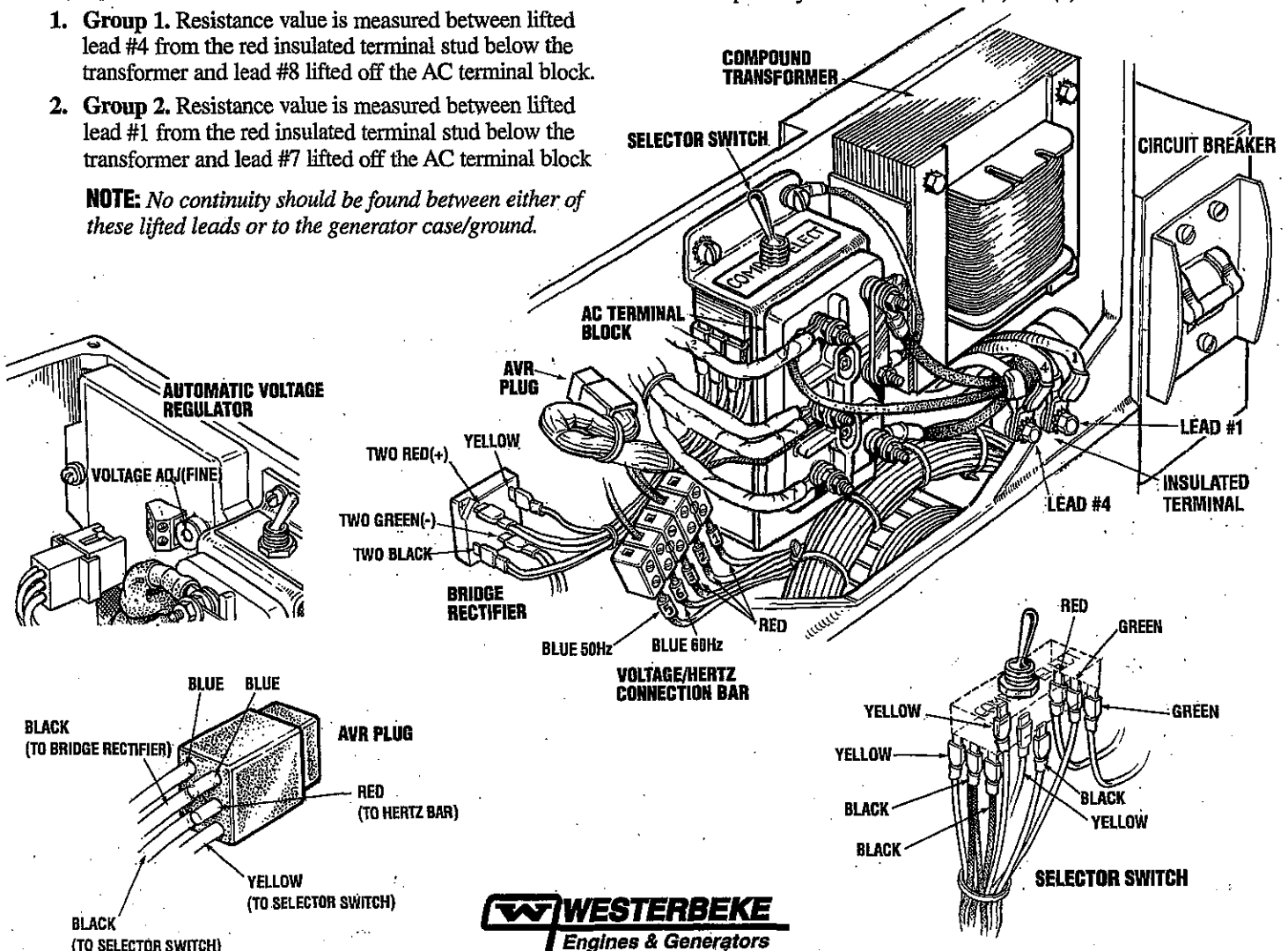

# BT GENERATOR TROUBLESHOOTING

## Exciter Rotor/Field

1. **Auxiliary windings group a, b and c.** Locate the three terminal points on the exciter rotor for these auxiliary winding groups. Position the exciter rotor as shown in the illustration and count off the porcelain knobs from the 12 o'clock point either left or right to locate terminal points a, b and c. Measure the resistance value between the pairs of terminal points A & B, B & C, and C & A. There is no need to unsolder these connections unless a faulty reading appears. If this occurs, unsolder and verify the winding fault. There should be no continuity found between any of the three terminal points and the rotor shaft/case ground.

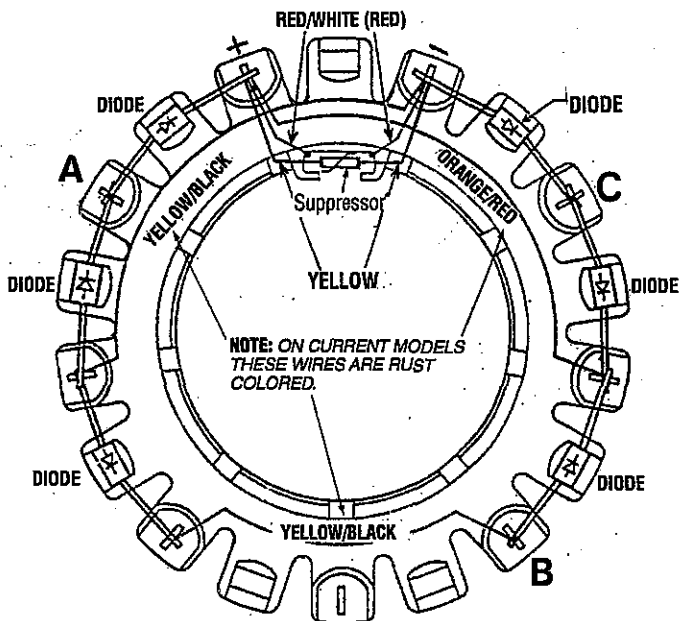

2. **Rotating Field Windings.** Refer to the illustration above of the exciter rotor. The field winding connections are noted as the (+) and (-) connections of the red & white striped wires. Measure the resistance value with your ohmmeter between these two connection points. These connections need not be unsoldered unless a faulty reading appears. If this occurs unsolder the connection and verify the resistance reading. With these connections lifted, there should be no continuity to the rotor shaft. This would indicate a short to ground with these field windings.

3. **Diodes.** Six diodes are mounted on the exciter rotor; they rectify the AC voltage produced by the three groups of auxiliary windings to DC voltages and supply this DC voltage to the rotating field windings. The diodes can be easily checked in place with the use of a common automotive 12-volt high beam headlight bulb, some jumper leads and the generator's 12 volt starting battery. A short or an open in a diode can easily be found with the above without having to unsolder and isolate each diode to check it with an ohmmeter.

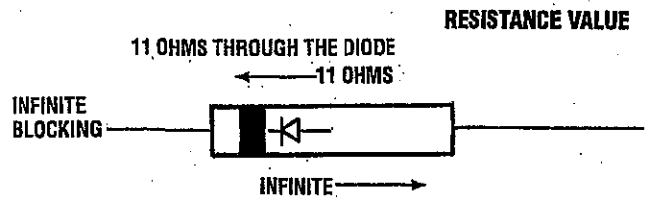

**NOTE:** Attempting to check diodes in place with an ohmmeter will give erroneous readings on the diodes due to the auxiliary winding's connections.

4. When leads are put across the diode, as illustrated, voltage passes through the diode allowing the headlight to glow brightly.

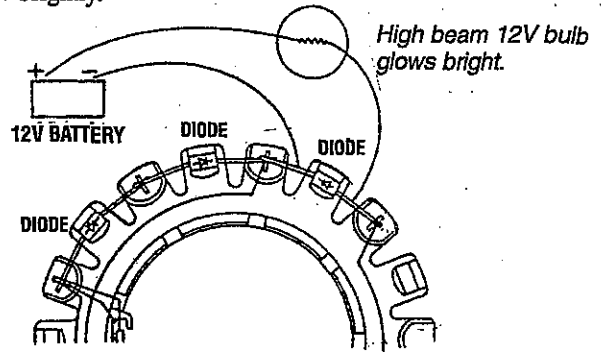

5. **Reverse the leads across the diode.** The diode should block voltage passing through it, and the headlight should not glow, or it may glow faintly.

- Should the bulb not glow with leads connected in both directions, the diode is open internally.
- Should the bulb glow with leads connected in both directions, the diode is shorted internally.

In both **a** and **b** above, the diode should be replaced. Check the resistance values of the rotating field windings and the integrity of the resistors connected between the field windings.

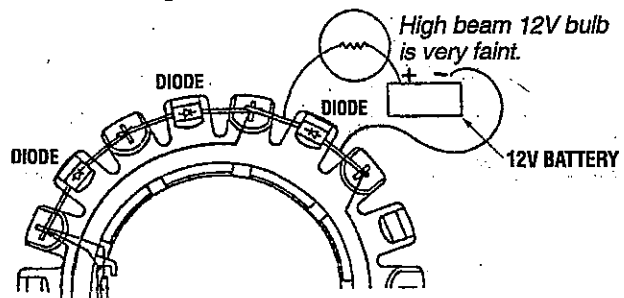

6. **Rotating Field Windings** Readings taken between the two red & white wires connected to the (+) and (-) terminals of the exciter rotor as shown.

7. **Suppressor.** Infinite readings between both yellow leads lifted from the (+) and (-) terminals on the exciter rotor. A short in the suppressor will cause a loss of the rotating field. AC output voltage will drop to zero.

# BT GENERATOR TROUBLESHOOTING/SINGLE PHASE

## No-Load Voltage Adjustment

Voltage adjustment is made with the generator regulation being governed by the compound transformer.

1. The selector switch *must* be in the COMP position.
2. To confirm no-load voltage, start the generator and apply a momentary (moderate) load to excite the transformer. The voltage produced by the generator after the momentary load is removed is no-load voltage. Note the voltage output from the generators 120 volt leg(s) (230 volt 50 hertz). The no-load voltage should be between 121-124 volts at 61.5-62 hertz (232- 236 volts at 51.5-52 hertz).
3. To raise or lower the voltage, shims of varying thickness (non-conductive material) are placed or removed from under the steel laminated bar on top of the compound transformer. The material used for shimming should not soften at temperatures in the 176° F (80° C) range. A small reduction in no-load voltage (1 to 3 volts) can some times be accomplished by gently tapping the top of the laminated steel bar to reduce the gap between the exist ing shims and the transformer core.

## VOLTAGE/HERTZ CONNECTION BAR

If there is no automatic voltage regulator (AVR) installed, do not change the wiring on the Voltage/Hertz Connection Bar. Simply reconfigure the AC voltage connections at the AC terminal for the hertz change.

The blue or blue/white lead should be connected to the Hertz terminal that the generator will be set to produce.

The order of the numbered connections on some Voltage/Hertz Connection Bars may be reversed (as in the diagrams below). To ensure a proper connection follow the blue/white or blue lead to the AC terminal block, it should connect to the correct terminal: stud 6(V1) for 50 Hz, 5(W2) for 60 Hz. See the *BT WIRING SCHEMATIC*.

**NOTE:** When the optional voltage regulator is installed and if the Blue/White (Blue) lead is not correctly positioned to correspond to the Hertz the unit is operating at, the regulator will sense incorrect voltage and cause the generator to produce abnormally high output voltage.

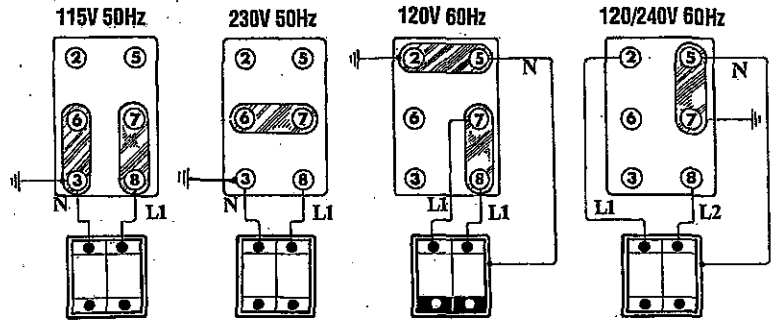
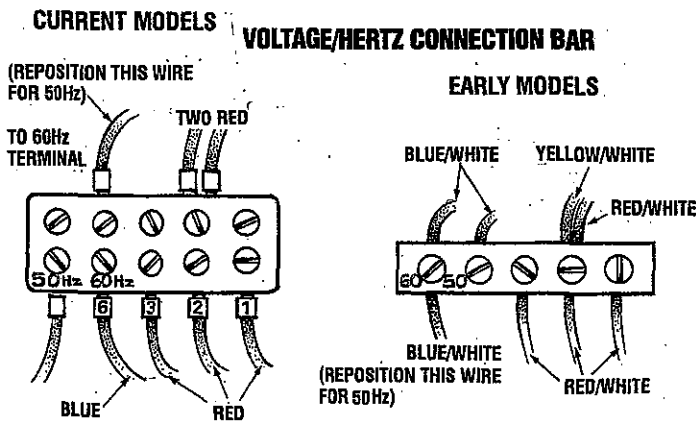

## BT Generator Six Stud AC Voltage Connections

**NOTE:** The frame ground wire must be moved when changing from 110 volts and 110/220 volts 50 hertz to 230 volts 50 hertz. For output leads from the AC terminal block, use terminal ends for 1/4 inch studs that will accept multi-strand copper wire sized for the amperage rating from the hot lead connection. The frame ground wire connects between the neutral stud and the generator frame.

## Generator Frequency

1. Frequency is a direct result of engine/generator speed:
  - 1800 rpm = 60 hertz;
  - 1500 rpm = 50 hertz.
2. To change generator frequency follow the steps below.
  - a. Connect the AC output leads to the AC terminal block, following the correct diagram above..
  - b. If an AVR is installed, reposition the blue or blue/white lead to correspond to the hertz selected on the Voltage/Hertz Connection Bar.
  - c. Start the engine, monitor voltage and adjust engine no-load speed. Adjust diesel units by the linkage between the throttle arm and fuel solenoid or the throttle lever on the injection pump.
    - 60 hertz: no-load speed, 61.5-62.0 hertz.
    - 50 hertz: no-load speed, 51.5-52.0 hertz.
  - d. After the no-load hertz adjustment is made, the no-load voltage may need to be readjusted. In most cases, if the generator was producing the correct no-load voltage at the previous hertz setting, it would be correct at the changed hertz setting.
 

In the event it needs adjustment, adjust the shim thickness under the laminated steel bar of the transformer.

    - 60 hertz: no-load voltage, 121-124 volts
    - 50 hertz: no-load voltage, 232-236 volts,
  - e. Load the generator to the rated amperage output corresponding to the hertz speed of the generator.
 

Rated Loaded Speed

    - 60 hertz: loaded speed, 58.5-59.0 hertz
    - 50 hertz: loaded speed, 48.5-49.0 hertz

The lowest acceptable voltage at full rated output (amps)

    - 60 hertz: 108-110 volts
    - 50 hertz: 205-210 volts

# BT GENERATOR TROUBLESHOOTING

f. Should the voltage drop below the proper rate, loaded excitation can be increased to raise this voltage by repositioning connections on the Voltage/Hertz Connection Bar. Repositioning the two leads (red/white and yellow/white) from (1) to (2) or (3) terminals will increase the loaded voltage out progressively in that order.

**NOTE:** No-load voltage may be effected needing readjustment with the compound transformer. Do not use these adjustments to compensate for overload conditions being placed on the generator/engine (inductive-motor type loads). Loss of generator hertz/speed, the result of overload, will cause a drop in voltage output.

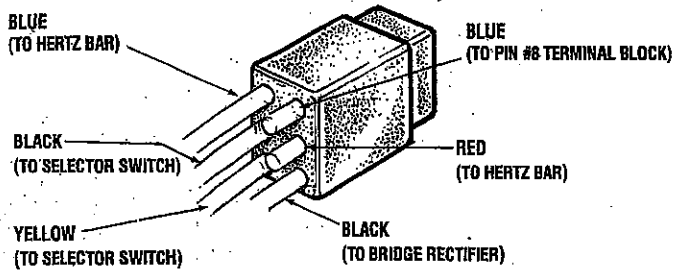

**A.V.R. Plug and Connections**

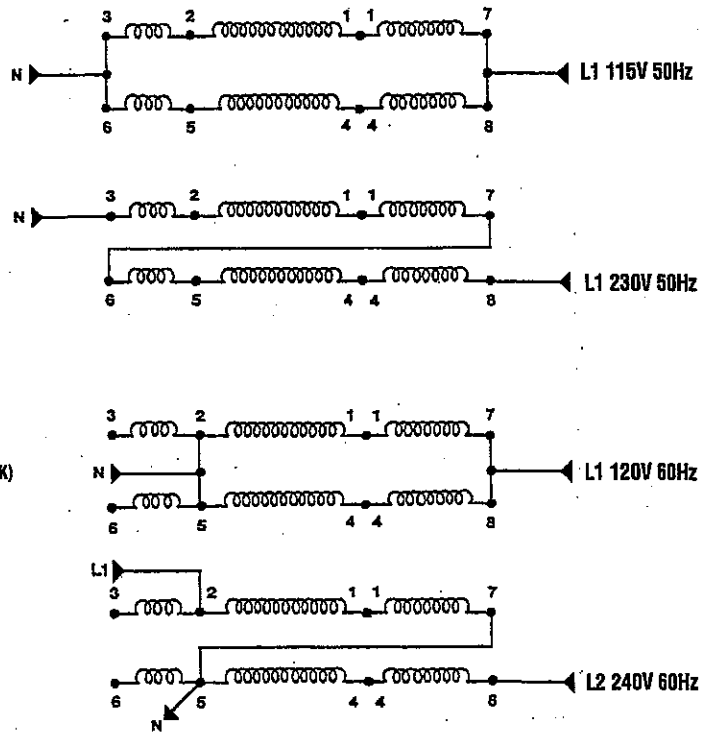

## Terminal Block Wiring Connections

Wiring connections needed to obtain proper voltage and frequency are illustrated in the diagrams above.

**NOTE:** Connections 1 and 4 are located on two red terminals below the compound transformer.

## AC TERMINAL BOARD CONNECTIONS [12 STUD]

**NOTE:** The frame ground wire must be moved when changing from 115V/50Hz to 230V/50Hz. The frame ground wire connects between the neutral stud and the generator frame.

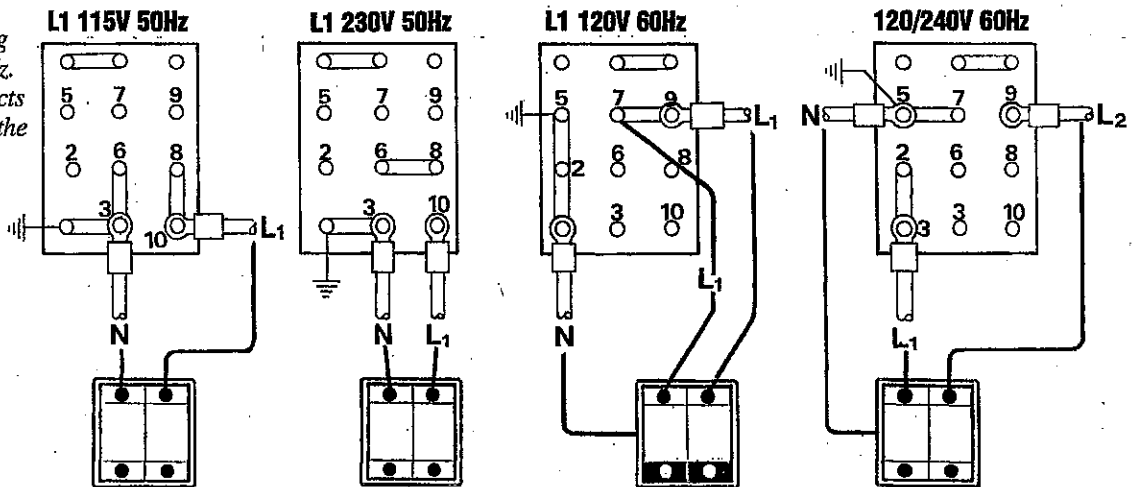

A JUMPER IS REQUIRED BETWEEN LOAD CONNECTIONS.

**NOTE:** For output leads from the AC terminal block use terminal ends for 1/4" studs that accept multi-strand copper wire sized for the average rating from the hot lead connection

# BT GENERATOR INTERNAL WIRING

## 3 PHASE TWELVE WIRE RECONNECTABLE

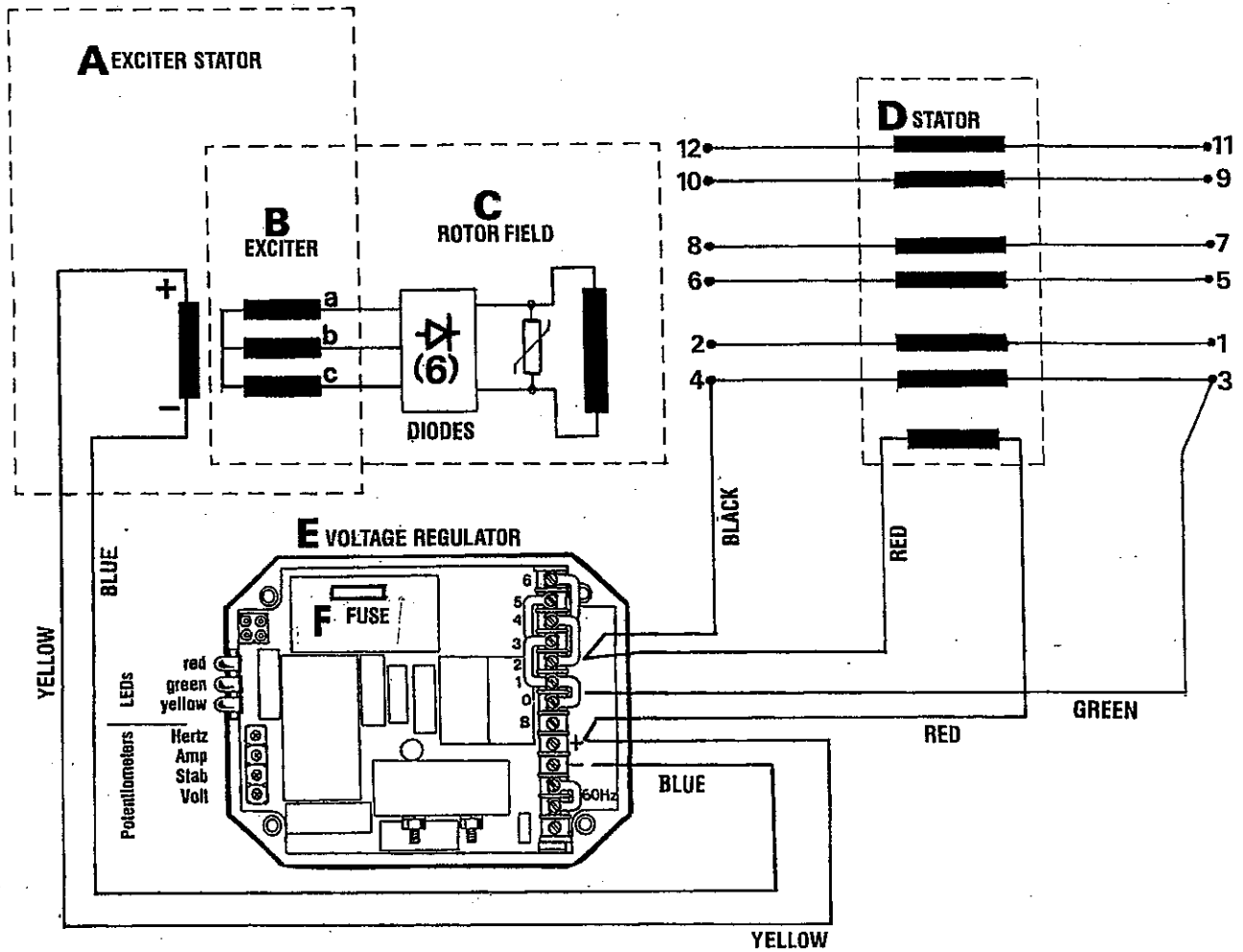

### RESISTANCE VALUES

- A. EXCITER STATOR (17.9 ohm)
- B. EXCITER ROTOR WINDINGS a b c (0.6 ohm)
- C. ROTATING FIELD (2.49 ohm)
- D. MAIN STATOR WINDINGS (0.05 ohm)  
AUXILIARY WINDING (1.2 ohm)
- E. VOLTAGE REGULATOR
- F. AUXILIARY CIRCUIT FUSE

# GENERATOR AC VOLTAGE CONNECTIONS BE THREE PHASE

## VOLTAGE REGULATORS THREE PHASE CONNECTIONS

The regulator is equipped with seven numbered terminals (0 to 6) and their related brass jumpers. The illustrations shown connection points and jumpers for the 3 phase configuration of the generator. The sensing leads connect between pin #1 and pin #2 on the AC terminal block and connection #2 and #0 on the voltage regulator board.

**NOTE:** Series Delta requires the installation of a jumper on the regulator board between terminal B and 0.

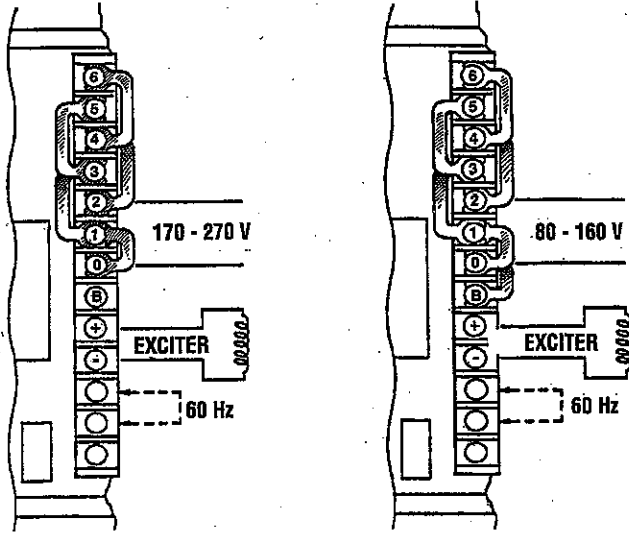

## AC TERMINAL CONNECTIONS THREE PHASE 12 WIRE

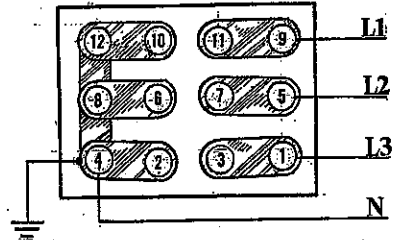

PARALLEL WYE (STAR)

L-N - 120 VAC	1Ø	60 HZ	L-L - 208 VAC	3Ø	60 HZ
L-N - 110 VAC	1Ø	50 HZ	L-L - 190 VAC	3Ø	50 HZ

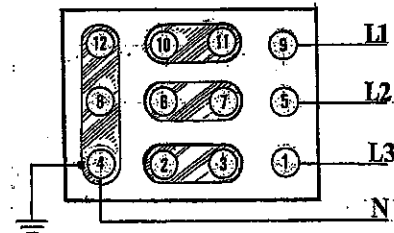

SERIES WYE (STAR)

L-L - 450 VAC	3Ø	60 HZ	L-L - 380 VAC	3Ø	50 HZ
L-N - 265 VAC	1Ø	60 HZ	L-N - 230 VAC	1Ø	50 HZ

## VOLTAGE SENSING CONNECTIONS

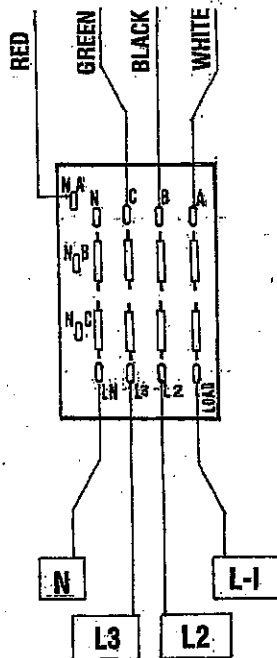

AC TERMINAL BLOCK

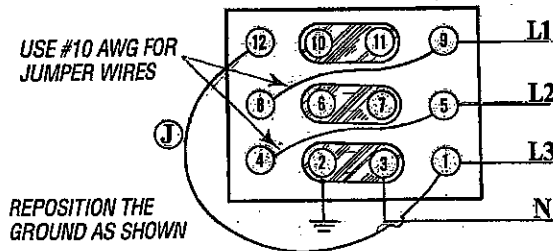

SERIES DELTA

L-L - 240 VAC	3Ø	60 HZ	L-L - 230 VAC	3Ø	50 HZ
L2, L3-N - 120 VAC	1Ø	60 HZ	L2, L3-N - 115 VAC	1Ø	50 HZ



# BT GENERATOR TROUBLESHOOTING/3 PHASE

**NOTE:** AC generator troubleshooting must be performed with the engine operatin at 60 Hz.

FAULT	PROBABLE CAUSE	
NO AC VOLTAGE OUTPUT AT NO LOAD.	<ol style="list-style-type: none"> <li>1. Short or open in the main stator winding.</li> <li>2. Shorted suppressor on exciter rotor.</li> <li>3. Four or more shorted or open diodes on exciter rotor.</li> </ol>	<ol style="list-style-type: none"> <li>4. Open in exciter stator winding.</li> <li>5. Open in rotating field winding.</li> </ol>
RESIDUAL VOLTAGE PRODUCED AT NO LOAD 15 - 20 VOLTS AC.	<ol style="list-style-type: none"> <li>1. Blown 6 AMP fuse auxiliary circuit AVR.</li> <li>2. Faulty voltage regulator</li> </ol>	<ol style="list-style-type: none"> <li>3. Shorted or open main stator auxillary winding.</li> </ol>
LOW AC VOLTAGE OUTPUT AT NO LOAD 60 - 100 VAC.	<ol style="list-style-type: none"> <li>1. Open or shorted diodes in exciter rotor 1 to 3 diodes.</li> <li>2. Shorted exciter rotor winding.</li> </ol>	<ol style="list-style-type: none"> <li>3. Faulty voltage regulator.</li> </ol>
HIGH AC OUTPUT VOLTAGE 150 VAC OR HIGHER.	<ol style="list-style-type: none"> <li>1. Faulty voltage regulator.</li> </ol>	
UNSTABLE VOLTAGE OUTPUT.	<ol style="list-style-type: none"> <li>1. STB pod on regulator needs adjustment.</li> </ol>	<ol style="list-style-type: none"> <li>2. Faulty voltage regulator.</li> </ol>

AC VOLTAGE DROP UNDER LOAD 60 - 100 VOLTS AC.

1. Diode(s) on exciter rotor breaking down when load is applied (inductive) 1-3 diodes.

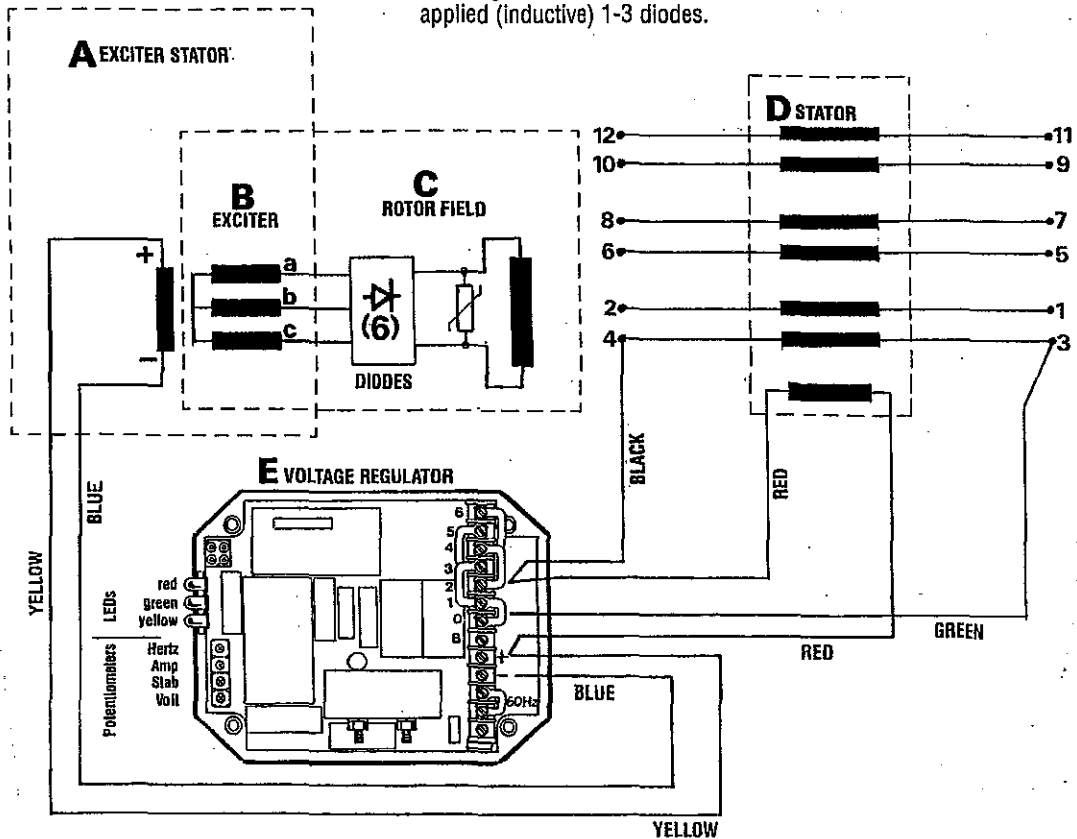

# BT GENERATOR VOLTAGE REGULATOR ADJUSTMENTS (3 PHASE)

## Description

The voltage regulator is an advanced design which ensures optimum AC generator performance. It is equipped with complete protection circuitry to guard against operating conditions that could be detrimental to the AC generator.

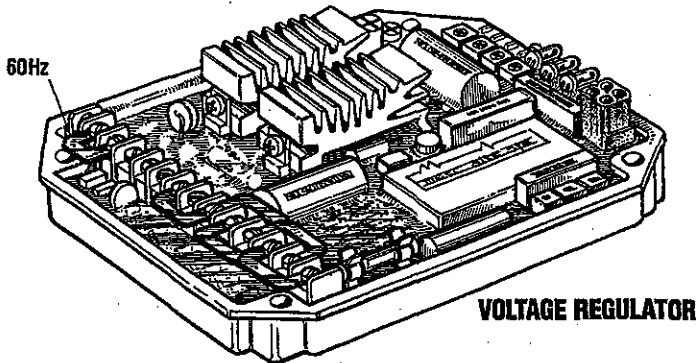

## Volts

This potentiometer is used to adjust output voltage. At proper engine operating speed the output voltage should be held at  $\pm 1\%$  from a no-load condition to a full rated generator output and from power factor 1.0 - 0.8 with engine drive speed variations up to -6%. Prior to starting the engine, turn the VOLT and STAB trimmers (using a mini phillips screw-driver) fully in a counter clockwise (Minimum) direction until you feel them hit their stops. Turn the AMP and HERTZ trimmers completely clockwise (Maximum) in the same manner. With the generator running at no-load, at normal speed, and with VOLT adjust at minimum, it is possible that output voltage will oscillate. Slowly rotate the VOLT adjust clockwise. The voltage output will increase and stabilize. Increase the voltage to the desired value. In this situation, only the green LED will stay lit.

## Stability

This potentiometer permits variation of the regulator's response to generator load changes so as to limit overcompensation and obtain a minimum recovery time to the normal voltage output.

In order to adjust the regulator stability the generator must be running at no-load and the output must be monitored.

Turn the STAB adjust slowly clockwise until the voltage starts to fluctuate. At this point rotate the STAB adjust counterclockwise until the voltage is stable within 1 or 2 tenths of a volt.

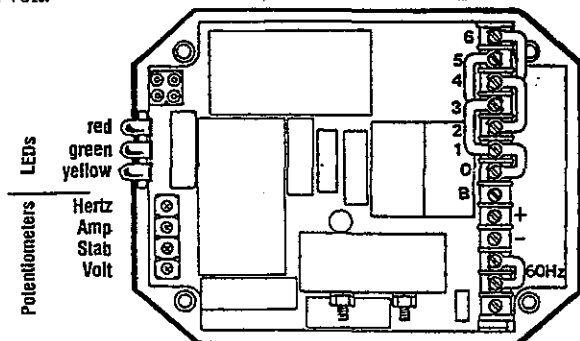

VOLTAGE REGULATOR DIAGRAM

## Amp-Hertz

These two adjustments are used in conjunction with the two protection circuits in the voltage regulator that are indicated by the illumination of colored LED lights.

1. Delayed overload protection (yellow LED).
2. Low speed protection (red LED).

Both systems have an intervention threshold which can be adjusted using the respective potentiometer. Each of the two circuits are able to cause an adequate reduction in excitor voltage to safeguard the excitor windings and prevent their overheating.

The overload protection system has a delay which permits temporary overloading of the generator during times such as motor start-up or other similar load surge demands. The regulator also has a third LED (green), that glows during generator operation to indicate correct operation of the regulator with the generator.

## Setting the Overload Protection

In order to set the AMP overload protection, the generator must be loaded to its full output rating.

1. Load the generator to its rating, then decrease the speed of the engine by 10.10% (54 Hertz on 60 hertz units, 45 hertz on 50 hertz units).
2. Rotate the AMP adjustment counterclockwise until it hits its stop. Wait about 15-20 seconds after which the AC output of the generator should drop and the yellow LED light should come on.
3. Slowly rotate the AMP adjustment clockwise until the output voltage increases to approximately 97% of the voltage output at the start of the adjustment. At this point the yellow LED light should come on.
4. Return to nominal speed, the yellow LED will turn off and the generator voltage will rise to its normal value. Should this not happen, repeat the adjustment.

**NOTE:** When changing from 60 hertz to 50 hertz operation, remove the 60 hertz jumper bar from the regulator board.

## Setting the Underspeed Protection

**NOTE:** If the unit is operating at 60 Hertz ensure that the jumper strap is in place on the regulator board between the two 60 Hertz terminals. In order to adjust the underspeed setting, the generator should be running at no-load.

1. To adjust the underspeed (low frequency) protection circuit, lower the engine speed at 90% of its normal running speed (54 hertz on 60 hertz units, 45 hertz on 50 hertz units).
2. Rotate the Hertz adjustment counterclockwise slowly until the generator's AC output voltage starts to decrease and at the same time the red "LED" light comes on.
3. Increase the engine speed to its normal speed (frequency). The red "LED" light will go out and the AC voltage output will return to normal.

With the above adjustments made, the regulator should function normally.

# GENERATOR WIRING DIAGRAM #44927 (WITH ELECTRONIC GOVERNOR)

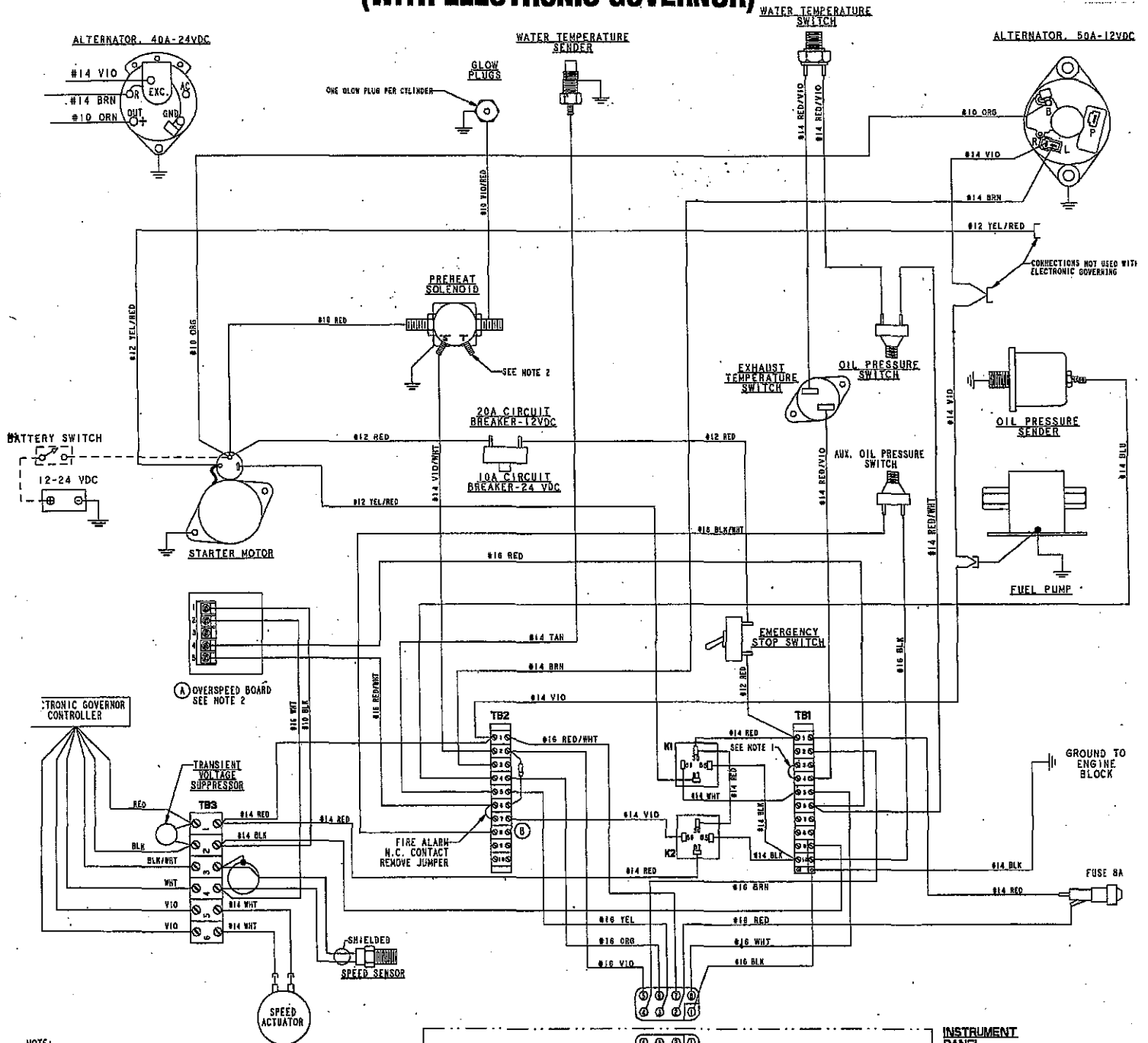

- NOTE:**
1. REMOVE JUMPER WHEN CONNECTING A SECOND REMOTE PANEL.
  2. GROUND "1" TERMINAL OF PREHEAT SOLENOID ON 24V SYSTEM ONLY.

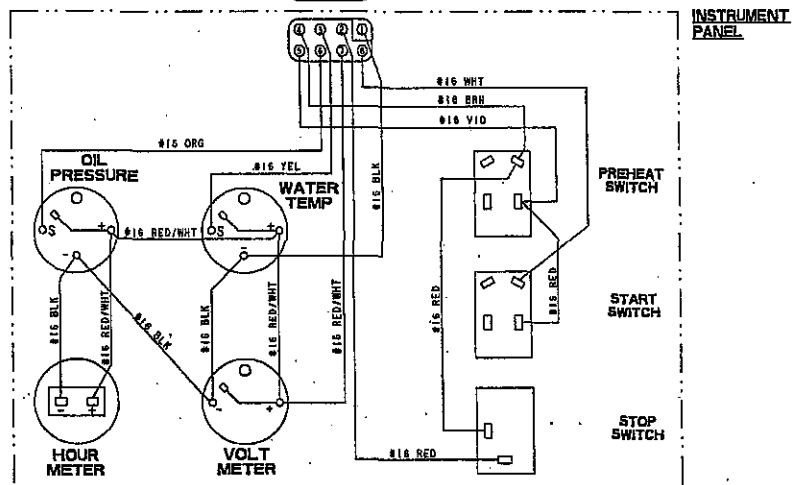
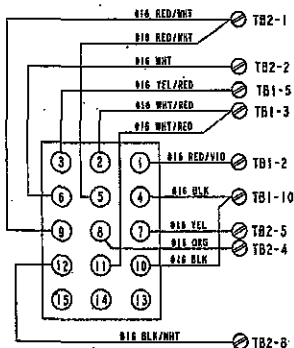

# GENERATOR WIRING SCHEMATIC #44927 (WITH ELECTRONIC GOVERNOR)

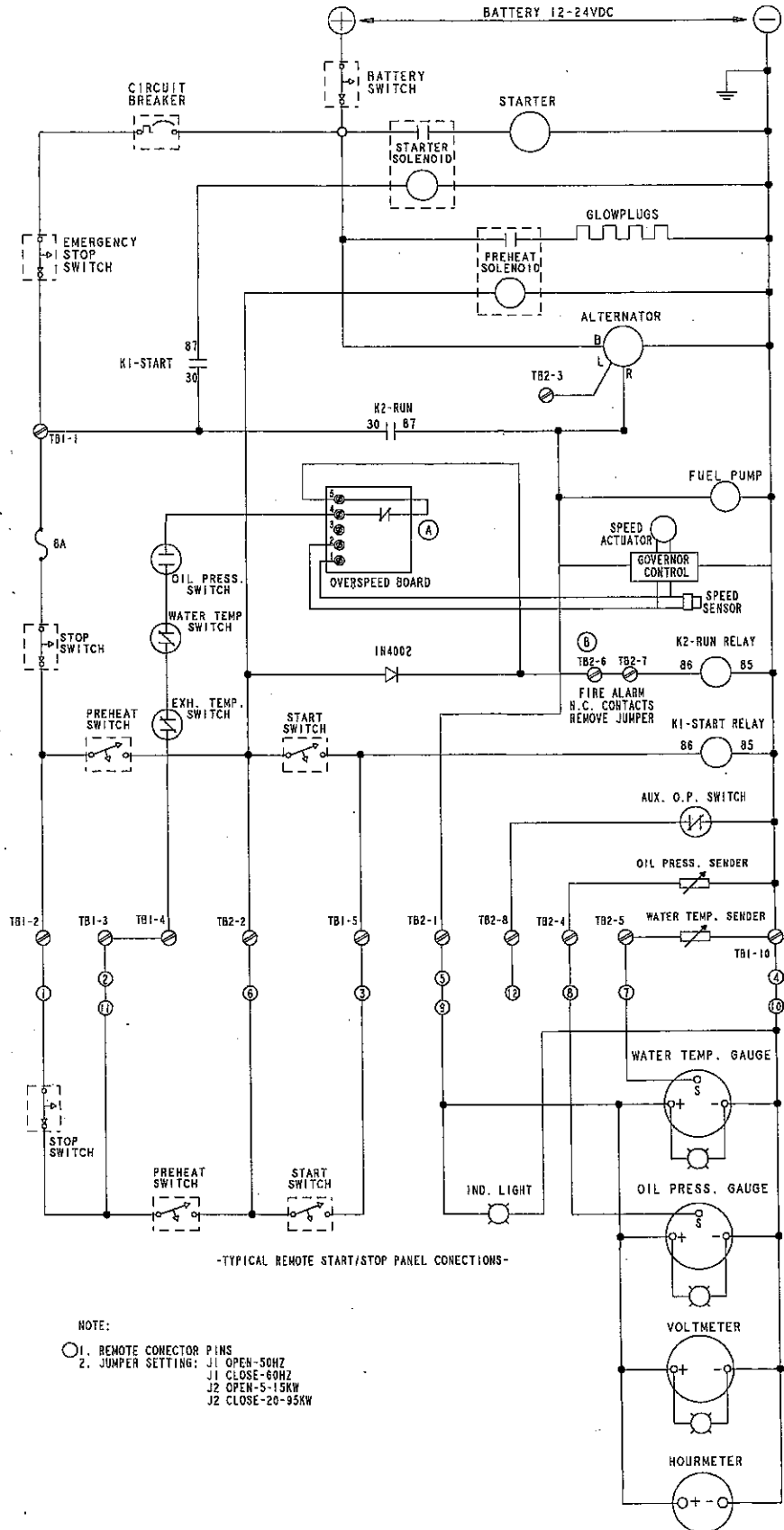

# ELECTRONIC GOVERNOR (OPTIONAL)

## ACTUATOR (ELECTRONIC GOVERNING)

The ECU (Electronic Control Unit) in the control box on the generator controls the engine speed electronically. The ECU senses engine speed from a signal sent to it from a MPU (Magnetic Pick Up) positioned on the flywheel bellhousing over the flywheel's ring gear teeth. The ECU continuously monitors this signal and if there is any discrepancy in this signal the ECU adjusts the DC voltage to the ACTUATOR positioning its plunger to let the injection pump fuel rack to allow more or less fuel delivery to maintain a constant engine speed depending on the amperage load on the generator. Maintaining a steady Hertz operation of the AC generator.

The following instructions are for adjusting or replacing the actuator.

1. Turn OFF the DC breaker on the control box.
2. Unplug the actuator from the engine harness. Back off the 1 7/16 jam nut that secures the actuator and unscrew it from the engine block.
3. Apply a small amount of teflon sealant to the actuators threads and screw it into the engine block 4 to 5 full turns. Just snug up the jam nut. Reconnect the actuator to the engine harness. Turn ON the DC breaker on the control box. **NOTE: Turn OFF the AC circuit breaker on the generator.**
4. Start the engine. Monitor the generator output frequency that it is operating at the selected frequency.
5. With the engine running, depress the STOP switch to test for proper engine shut down. If the engine does not shut down and only goes to a slow idle speed, loosen the jam nut and thread the actuator in slowly until a full shut down takes place. Then thread the actuator in 1/2 turn and secure it in place with a jam nut. Un-twist the actuator wires as needed. This adjustment should now allow the engine to start and stop under normal operating conditions.

A final adjustment may be necessary after the genset has operated approximately 20 minutes and has reached its normal operating temperature. If the engine shuts down properly under normal operating conditions, but fails to shut down fully under more extreme conditions such as running at high amperage loads for a long period of time and/or under extreme ambient temperatures. The actuator may need to be turned in an additional 1/2 turn.

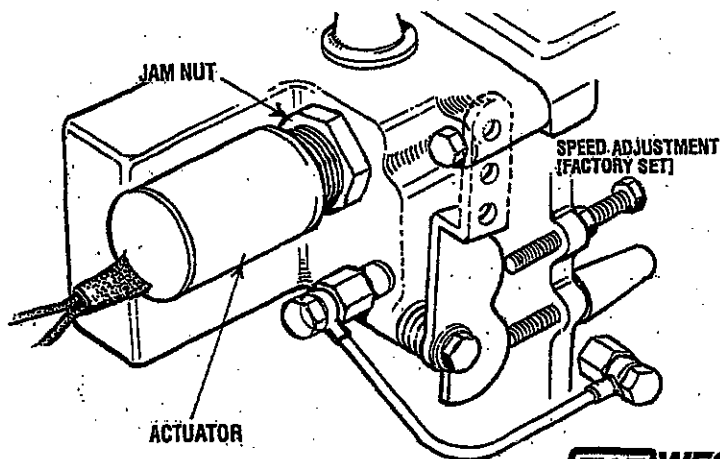

## MAGNETIC PICK-UP [MPU] INSTALLATION

The MPU is installed in the threaded opening on the side of the flywheel bellhousing. This positions the MPU over the teeth of the flywheel ring gear.

Viewing through this opening, manually rotate the engine crankshaft so as to position the flat of one of the ring gear's teeth directly under the opening. Thread the MPU into the opening until it gently contacts the flat of this tooth (Thread is 3/8" x 24). Back the MPU out of the opening one turn and then lock it in this position with the jam nut. This will position the end of the MPU approximately 0.030 inches away from the flats of the ring gear teeth.

To ensure the MPU is positioned correctly, slowly rotate the crankshaft by 360° by hand to assure there is no physical contact between the MPU and the ring gear teeth.

If contact is felt between the MPU and the flywheel teeth, the MPU may be damaged. Remove the MPU and inspect it. Replace if necessary and repeat the above installation procedure.

**NOTE:** When replacing the Magnetic Pick-Up (MPU) it **MUST** be replaced without cutting and splicing into the existing wiring cable. Doing so will cause a erratic AC signal to the controller.

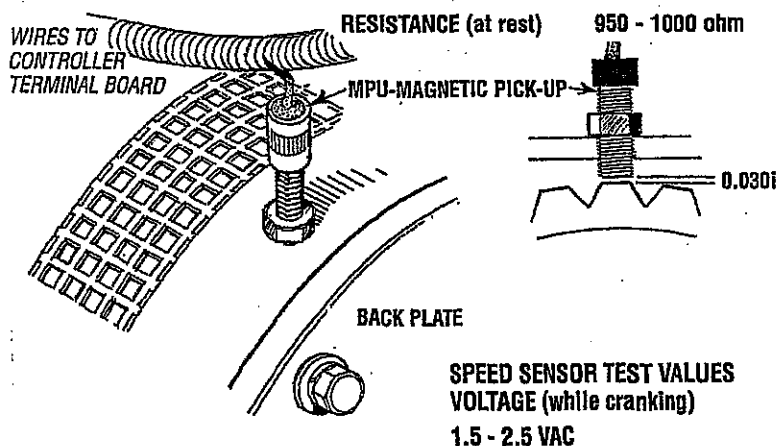

## GOVERNOR CIRCUIT VOLTAGES

Below are the voltages normally found in the governor circuit when the system is functioning normally. These voltages are an approximate and should help in troubleshooting a system that is not functioning correctly.

### DC Voltage into Controller

Bat + to Bat - (battery charging voltage 13.5 - 14.5 VDC)  
(Terminal block #1 and #2)

### DC Voltage to Actuator

ACT to ACT (5.5 - 6.5 VDC)  
(Terminal block #5 and #6)

### AC Voltage from MPU into Controller

MPU to MPU (2.5 - 7.0 VAC)  
(Terminal block #3 and #4)

This voltage spread is the result of the distance the MPU is positioned from the flat of the flywheel ring gear tooth. The closer to the tooth, the higher the AC signal. The further away, the lower the AC signal.

# ELECTRONIC GOVERNOR (OPTIONAL)

## DESCRIPTION

The system is composed of three basic components:

1. **Controller.** A solid state component mounted in the control box on the generator.
2. **MPU (Speed Sensor).** Installed on the bellhousing over the flywheel ring gear teeth.
3. **Linear Actuator.** Threaded into the engine block just behind and below the fuel injection pump

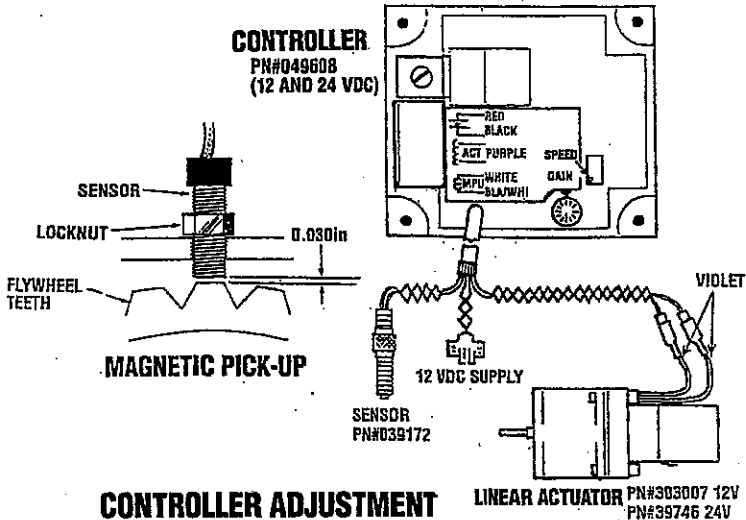

## CONTROLLER ADJUSTMENT

1. **Speed.** This adjustment is used to raise or lower the engine's speed to the desired hertz.
2. **Gain.** This adjustment affects the reaction time of the actuator to the generator/engine load changes.

**NOTE:** A high gain adjustment can induce an oscillating of the actuator producing a hunting mode. In such cases, lessen the gain adjustment.

## Calibration

1. With no power to the governor, adjust the GAIN to 9:00 o'clock.
2. Start the engine and adjust the speed by either turning the speed potentiometer clockwise or depress and hold the INC (increase) pad until the desire speed is obtained.

**NOTE:** Controllers are factory adjusted to minimum rpm. However, for safety, one should be capable of disabling the engine if an overspeed should exist.

3. At no-load, turn the GAIN potentiometer clockwise until the engine begins to hunt. if the engine does not hunt, physically upset the governor linkage.
4. Turn the GAIN potentiometer counterclockwise until stable.

**NOTE:** The controller operates on 12VDC. The voltage range is  $\pm 20\%$  (9.6VDC 12VDC 14.4VDC). If voltage varies above or below these ranges, the controller will not operate and the engine will run in an idle mode until proper voltage is supplied to the controller.

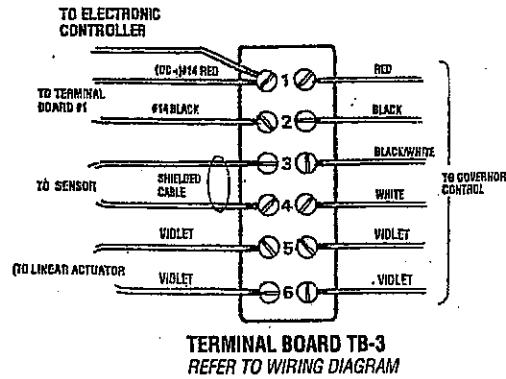

## INSPECTION AND ADJUSTMENT

The system has two styles of electronic controllers. The early version (black encapsulated components) with 2 adjustments, a speed potentiometer and a GAIN adjustment. This controller is NLA. The current electronic controller (aluminum housing with components inside) has two push pads for speed adjustment. One pad to increase speed (INC) and one pad to decrease speed (DEC). It also has the GAIN adjustment,

These two electronic controllers are illustrated on this page. When you press the preheat button, DC voltage is sent to the controller to function with.

The engine is started, the new controller will operate the engine in the 800-1000 range. Adjust the engine speed by depressing and holding the INC pad until the speed reaches the desired rpm (hertz) as possible.

The GAIN adjustment has been discussed earlier under CALIBRATION. Place an amperage load on the generator and note its reaction to the load. If the system is slow to react and maintain the set speed, adjust the GAIN slightly higher. The electronic governor system will maintain a set speed at + or - 0.5 hertz from no amperage load to full rated amperage load for the generator.

**NOTE:** When stopping the unit, the engine only goes to a low idle and does not shut down fully, the actuator will need a slight adjustment to provide complete stopping of the unit. Thread the actuator in 1/4 turn- 1/2 turn until complete stopping of the engine is obtained.

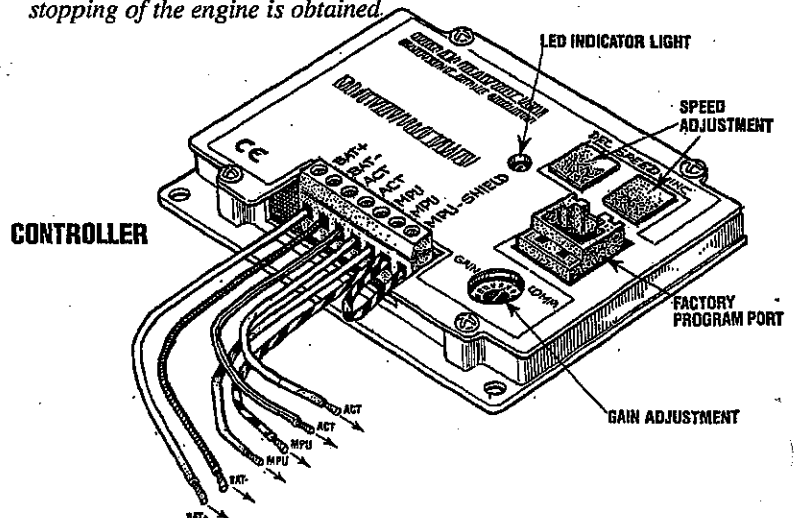

# LINEAR ACTUATOR TROUBLESHOOTING

Problem	Test/Check	Correct
System appears dead. (No actuator movement) Engine runs, but at idle speed	<ol style="list-style-type: none"> <li>1. Check the battery voltage at the controller terminal block with the Preheat switch depressed.</li> <li>2. If there is no signal or a weak signal from the MPU, measure the AC voltage being produced by the MPU while cranking the engine. Measure between the white and black/white wire leads on the controller terminal strip. While cranking the engine or it is running at idle, the voltage should be 2.0-3.0 volts AC. <b>NOTE:</b> The AC input impedance of meter must be 5000 ohms/volts or greater. <b>NOTE:</b> When making this test in diesel units, disable the preheat solenoid by disconnecting the "S" terminal connection so as not to damage the glow plugs.</li> <li>3. Check the actuator with the Preheat switch depressed. This provides DC voltage to the controller. Measure the DC voltage between the actuator connections on the controller block and the black DC (-) power connection on the controller terminal block. Both connections should have battery voltage +0.00 or -0.75 VDC.               <ol style="list-style-type: none"> <li>a. Purple lead to Black DC (-).</li> <li>b. Purple lead/purple/white lead to Black DC (-).</li> </ol> <p><b>NOTE:</b> Continue this test (ONLY) if the battery voltage is not present.</p> <ol style="list-style-type: none"> <li>c. The following checks are performed between the connections at the actuator and the Black DC (-) connection on the controller terminal block. This is to determine if there is a break in the line between the controllers terminal block connection and the actuator connections or the actuator leads themselves.                   <ol style="list-style-type: none"> <li>1) Low voltage (1.0-2.0 VDC) at either actuator connections.</li> <li>2) Battery voltage at both actuator connections.</li> <li>3) Battery voltage at one actuator connection but not at the second.</li> </ol> </li> </ol> </li> </ol>	<ol style="list-style-type: none"> <li>1. Inspect the DC circuit back to the starting battery.</li> <li>2. Check for damage to or improper adjustment of magnetic pick-up. replace or re-adjust.</li> <li>3. Low voltage (1.0-2.0 VDC) at either actuator connections.               <ol style="list-style-type: none"> <li>a. Replace the controller if battery voltage is not present at both the Purple leads.</li> </ol> </li> </ol>
Actuator	<ol style="list-style-type: none"> <li>1. Check the controller by removing the two. purple leads one at a time that come from the actuator off the controller terminal block. Lift one actuator lead and depress the preheat/on switch. Reconnect and do the same with the second.               <ol style="list-style-type: none"> <li>a. Actuator does not retract (Diesel).</li> <li>b. Shorted/open coil in actuator.</li> </ol> </li> </ol>	<ol style="list-style-type: none"> <li>1. Check for a shorted actuator lead. Replace the controller because it should not cause the actuator lever to go to full fuel when the engine is not running.               <ol style="list-style-type: none"> <li>a. Replace controller.</li> <li>b. Check resistance of actuator coil. 12 Volt 3.0 - 3.1 ohm 24 volt 10.7 - 10.8 ohm</li> </ol> </li> </ol>
Actuator (removed)		
Unit hunts during operation.	<ol style="list-style-type: none"> <li>1. Improper governor adjustment.</li> <li>2. Inadequate power supply voltage.               <ol style="list-style-type: none"> <li>a. Connect a DC voltmeter to Red (+) and Black (-) leads at the controller terminal block.</li> <li>b. Disconnect both leads coming from actuator from controller terminal block.</li> <li>c. Connect one lead from the actuator to the Red (+) on the terminal block and the other actuator lead to the Black (-) on the terminal block.</li> <li>d. Momentarily energize the start switch. The actuator should fully retract as long as the switch is depressed. Measure the DC voltage across the Red (+) and Black (-) leads while performing this test. DC voltage must be greater than 80% of the DC voltage measured across the battery supply. 9.0 VDC minimum 30.0 VDC maximum <b>NOTE:</b> Reconnect the actuator leads properly after completing this test.</li> <li>e. MPU positioned marginally too far away from flywheel teeth giving erratic AC input to controller.</li> </ol> </li> </ol>	<ol style="list-style-type: none"> <li>1. Re-adjust the calibration.</li> <li>2. If actuator doesn't fully retract (then check the actuator leads. If the voltage is less than specified, check for loose or poor connections in the DC circuit back to the battery, check the K2 relay and its connections.               <ol style="list-style-type: none"> <li>a. Check the position of the MPU.</li> <li>f. Check resistance value 950 - 1000 ohm</li> </ol> </li> </ol>

If problems continue to persist, contact your WESTERBEKE dealer for additional assistance.

# SPECIAL TOOLS - GENERATOR

## FIELD FABRICATED TOOLS

These drawings provide a means by which simple tools can be made to assist in the removal of the generator end from the engine and in the replacement of the generator end on the engine. A local machine shop should be able to fabricate these tools at a modest price, but first check with your local WESTERBEKE dealer to see if these tools are on hand for loan.

### Housing Puller Tool

This tool allows the bearing in the generator housing to be gently pushed straight off the housing without any twisting. If a nut of the same specifications as that of the tapped hole in the pilot tool were to be welded on the end of the eye bolt, this tool would be able to pull the bearing back into place without any twisting. Please refer to these drawings before the generator end is removed.

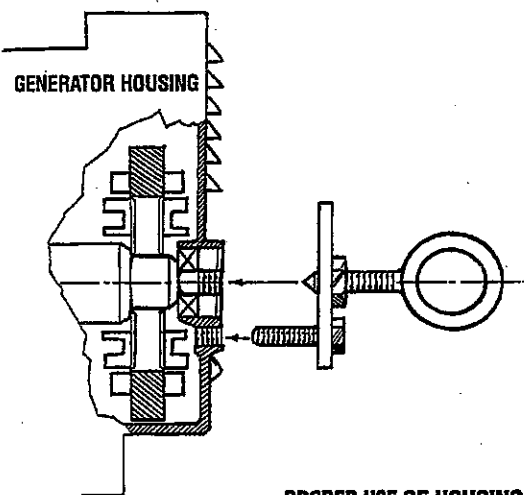
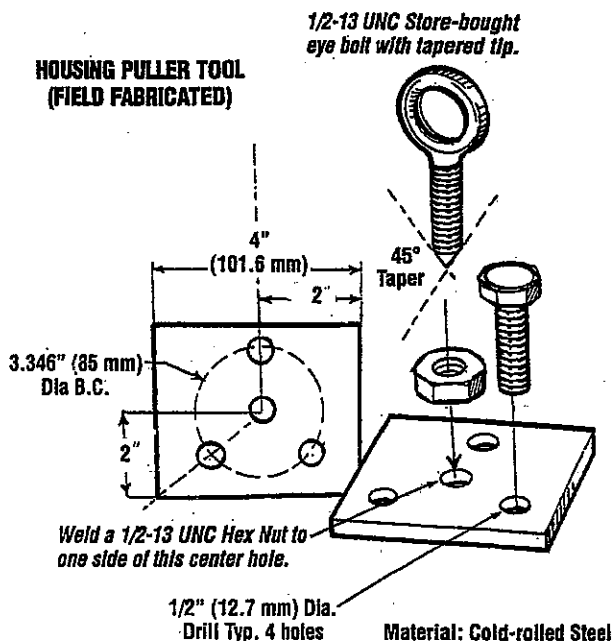

### Lifting Eye Tool

This tool allows a mechanic to safely remove the generator end from the engine by attaching this Generator End Lifting Eye to the four screw holes located under the control panel. To use this Lifting Eye, remove the generator's control panel and screw the Lifting Eye to the generator end.

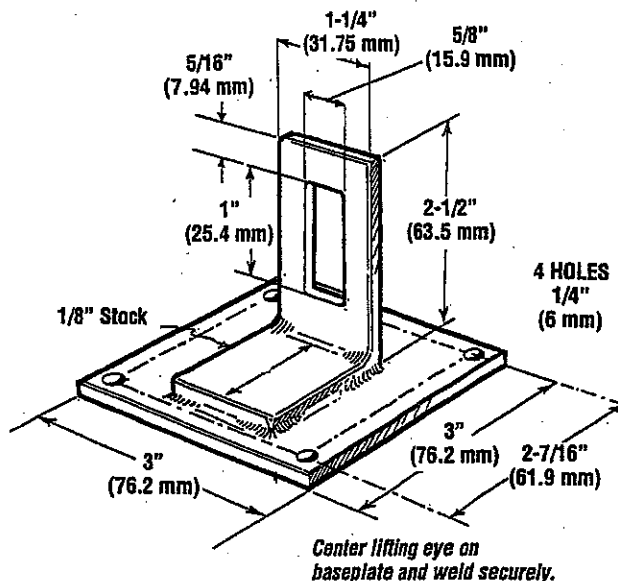

### Disk Alignment Tool

This tool allows a mechanic to safely remove and install the generator drive disks by aligning the disks with the Drive Plate Guide Pin. The Pin screws into the flywheel and acts as a guide. Also the pin helps to support some of the rotor and the drive plate's weight while removing or replacing these parts.



Material: One M8 bolt with the hex head machined off and a screwdriver slot cut in the machined end.

### Pilot Tool

The tool below helps keep the rotor from damaging the windings in the generator housing to be removed straight off the engine or to be placed straight on the engine. Refer to the removal and replacement diagram at the bottom of the page.

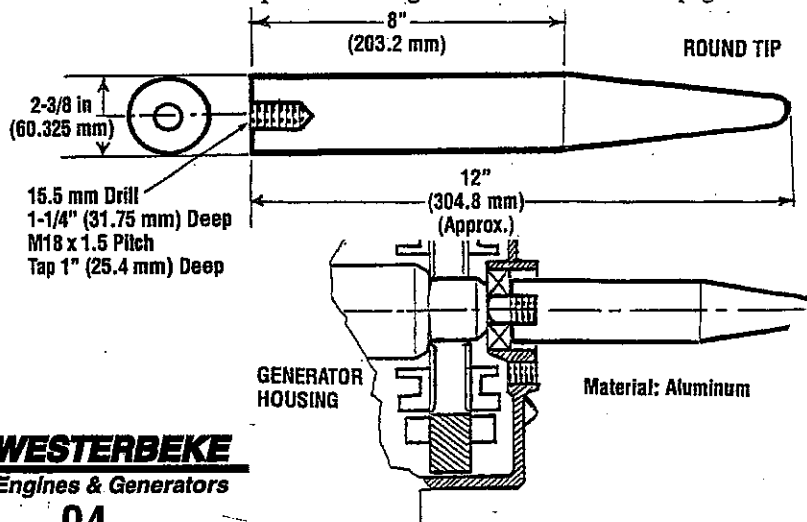



# STANDARD HARDWARE

## BOLT HEAD MARKINGS

Bolt strength classes are embossed on the head of each bolt.

**Customary (inch) bolts** are identified by markings two to grade eight (strongest). The marks correspond to two marks less than the actual grade, i.e., a grade seven bolt will display five embossed marks.



**Metric bolt class numbers** identify bolts by their strength with 10.9 the strongest.



- NOTES:**
1. Use the torque values listed below when specific torque values are not available.
  2. These torques are based on clean, dry threads. Reduce torque by 10% when engine oil is used.
  3. Reduce torques by 30% or more, when threading capscrews into aluminum.

STANDARD BOLT & NUT TORQUE SPECIFICATIONS			
Capscrew Body Size (Inches) - (Thread)	SAE Grade 5 Torque Ft-Lb (Nm)	SAE Grade 6-7 Torque Ft-Lb (Nm)	SAE Grade 8 Torque Ft-Lb (Nm)
1/4 - 20 - 28	8 (11) 10 (14)	10 (14)	12 (16) 14 (19)
5/16 - 18 - 24	17 (23) 19 (26)	19 (26)	24 (33) 27 (37)
3/8 - 16 - 24	31 (42) 35 (47)	34 (46)	44 (60) 49 (66)
7/16 - 14 - 20	49 (66) 55 (75)	55 (75)	70 (95) 78 (106)
1/2 - 13 - 20	75 (102) 85 (115)	85 (115)	105 (142) 120 (163)
9/16 - 12 - 18	110 (149) 120 (163)	120 (163)	155 (210) 170 (231)
5/8 - 11 - 18	150 (203) 170 (231)	167 (226)	210 (285) 240 (325)
3/4 - 10 - 16	270 (366) 295 (400)	280 (380)	375 (508) 420 (569)
7/8 - 9 - 14	395 (536) 435 (590)	440 (597)	605 (820) 675 (915)
1 - 8 - 14	590 (800) 660 (895)	660 (895)	910 (1234) 990 (1342)

METRIC BOLT & NUT TORQUE SPECIFICATIONS					
Bolt Dia.	Wrench Size	Grade 4.6 Ft-Lb (Nm)	Grade 4.8 Ft-Lb (Nm)	Grade 8.8 - 9.8 Ft-Lb (Nm)	Grade 10.9 Ft-Lb (Nm)
M3	5.5 mm	0.3 (0.5)	0.5 (0.7)	1 (1.3)	1.5 (2)
M4	7 mm	0.8 (1.1)	1 (1.5)	2 (3)	3 (4.5)
M5	8 mm	1.5 (2.5)	2 (3)	4.5 (6)	6.5 (9)
M8	10 mm	3 (4)	4 (5.5)	7.5 (10)	11 (15)
M9	13 mm	7 (9.5)	10 (13)	18 (25)	35 (26)
M10	16 mm	14 (19)	18 (25)	37 (50)	55 (75)
M12	18 mm	26 (35)	33 (45)	63 (85)	97 (130)
M14	21 mm	37 (50)	55 (75)	103 (140)	151 (205)
M16	24 mm	59 (80)	85 (115)	159 (215)	232 (315)
M18	27 mm	81 (110)	118 (160)	225 (305)	321 (435)
M20	30 mm	118 (160)	166 (225)	321 (435)	457 (620)
M22	33 mm	159 (215)	225 (305)	435 (590)	620 (840)
M24	36 mm	203 (275)	288 (390)	553 (750)	789 (1070)
M27	41 mm	295 (400)	417 (565)	811 (1100)	1154 (1585)
M30	46 mm	402 (545)	568 (770)	1103 (1495)	1571 (2130)
M33	51 mm	546 (740)	774 (1050)	1500 (2035)	2139 (2900)
M36	55 mm	700 (950)	992 (1345)	1925 (2610)	2744 (3720)

**NOTE:** Formula to convert Ft-Lbs to Nm (Newton Meters) multiply Ft-Lbs by 1.356.

## SEALANTS & LUBRICANTS

### GASKETS/SEALANTS

Oil based PERMATEX #2 and it's HIGH TACK equivalent are excellent all purpose sealers. They are effective in just about any joint in contact with coolant, raw water, oil or fuel.

A light coating of OIL or LIQUID TEFLON can be used on rubber gaskets and O-rings.

LOCTITE hydraulic red sealant should be used on oil adapter hoses and the oil filter assembly.

Coat both surfaces of the oil pan gasket with high temp RED SILICONE sealer.

When installing gaskets that seal around water (coolant) passages, coat both sides with WHITE SILICONE grease.

High-copper ADHESIVE SPRAYS are useful for holding gaskets in position during assembly.

Specialized gasket sealers such as HYLOMAR work well in applications requiring non-hardening properties. HYLOMAR is particularly effective on copper cylinder-head gaskets as it resists fuel, oil and water.

Use LIQUID TEFLON for sealing pipe plugs and fillings that connect coolant passages. **Do not use tape sealants!**

### BOLTS & FASTENERS/ASSEMBLIES

Lightly oil head bolts and other fasteners as you assemble them. Bolts and plugs that penetrate the water jacket should be sealed with PERMATEX #2 or HIGH TACK.

When assembling the flywheel, coat the bolt threads with LOCTITE blue.

Anti-seize compounds and thread locking adhesives such as LOCTITE protect threaded components yet allows them to come apart when necessary.

LOCTITE offers levels of locking according to the job.

LITHIUM based grease is waterproof, ideal for water pump bearings and stuffing boxes.

Heavily oil all sliding and reciprocating components when assembling. **Always use clean engine oil!**

# STANDARD AND METRIC CONVERSION DATA

## LENGTH-DISTANCE

Inches (in) x 25.4 = Millimeters (mm) x .0394 = Inches  
Feet (ft) x .305 = Meters (m) x 3.281 = Feet  
Miles x 1.609 = Kilometers (km) x .0621 = Miles

## VOLUME

Cubic Inches (in<sup>3</sup>) x 16.387 = Cubic Centimeters x .061 = in<sup>3</sup>  
Imperial Pints (IMP pt) x .568 = Liters (L) x 1.76 = IMP pt  
Imperial Quarts (IMP qt) x 1.137 = Liters (L) x .88 = IMP qt  
Imperial Gallons (IMP gal) x 4.546 = Liters (L) x .22 = IMP gal  
Imperial Quarts (IMP qt) x 1.201 = US Quarts (US qt) x .833 = IMP qt  
Imperial Gallons (IMP gal) x 1.201 = US Gallons (US gal) x .833 = IMP gal  
Fluid Ounces x 29.573 = Milliliters x .034 = Ounces  
US Pints (US pt) x .473 = Liters(L) x 2.113 = Pints  
US Quarts (US qt) x .946 = Liters (L) x 1.057 = Quarts  
US Gallons (US gal) x 3.785 = Liters (L) x .264 = Gallons

## MASS-WEIGHT

Ounces (oz) x 28.35 = Grams (g) x .035 = Ounces  
Pounds (lb) x .454 = Kilograms (kg) x 2.205 = Pounds

## PRESSURE

Pounds Per Sq In (psi) x 6.895 = Kilopascals (kPa) x .145 = psi  
Inches of Mercury (Hg) x .4912 = psi x 2.036 = Hg  
Inches of Mercury (Hg) x 3.377 = Kilopascals (kPa) x .2961 = Hg  
Inches of Water (H<sub>2</sub>O) x .07355 = Inches of Mercury x 13.783 = H<sub>2</sub>O  
Inches of Water (H<sub>2</sub>O) x .03613 = psi x 27.684 = H<sub>2</sub>O  
Inches of Water (H<sub>2</sub>O) x .248 = Kilopascals (kPa) x 4.026 = H<sub>2</sub>O

## TORQUE

Pounds-Force Inches (in-lb) x .113 = Newton Meters (Nm) x 8.85 = in-lb  
Pounds-Force Feet (ft-lb) x 1.356 = Newton Meters (Nm) x .738 = ft-lb

## VELOCITY

Miles Per Hour (MPH) x 1.609 = Kilometers Per Hour (KPH) x .621 = MPH

## POWER

Horsepower (Hp) x .745 = Kilowatts (Kw) x 1.34 = MPH

## FUEL CONSUMPTION

Miles Per Hour IMP (MPG) x .354 = Kilometers Per Liter (Km/L)  
Kilometers Per Liter (Km/L) x 2.352 = IMP MPG  
Miles Per Gallons US (MPG) x .425 = Kilometers Per Liter (Km/L)  
Kilometers Per Liter (Km/L) x 2.352 = US MPG

## TEMPERATURE

Degree Fahrenheit (°F) = (°C X 1.8) + 32  
Degree Celsius (°C) = (°F - 32) x .56

# METRIC CONVERSIONS

## INCHES TO MILLIMETERS

## MILLIMETERS TO INCHES

Inches	mm	Inches	mm	mm	Inches	mm	Inches
1	25.40	15	381.00	1	0.0394	15	0.5906
2	50.80	20	508.00	2	0.0787	20	0.7874
3	76.20	25	635.00	3	0.1181	25	0.9843
4	101.60	30	762.00	4	0.1575	30	1.1811
5	127.00	35	889.00	5	0.1969	35	1.3780
10	254.00	40	1016.00	10	0.3937	40	1.5748

10 MILLIMETERS = 1 CENTIMETER, 100 CENTIMETERS = 1 METER = 39.37 INCHES (3.3 FEET)

## INCHES TO METERS

## METERS TO INCHES

Inches	Meters	Inches	Meters	Meters	Inches	Meters	Inches
1	0.0254	7	0.1778	0.1	3.937	0.7	27.559
2	0.0508	8	0.2032	0.2	7.874	0.8	31.496
3	0.0762	9	0.2286	0.3	11.811	0.9	35.433
4	0.1016	10	0.2540	0.4	15.748	1.0	39.370
5	0.1270	11	0.2794	0.5	19.685	1.1	43.307
6	0.1524	12	0.3048	0.6	23.622	1.2	47.244

TO CONVERT METERS TO CENTIMETERS, MOVE DECIMAL POINT TWO PLACES TO THE RIGHT

## YARDS TO METERS

## METERS TO YARDS

Yards	Meters	Yards	Meters	Meters	Yards	Meters	Yards
1	0.91440	6	5.48640	1	1.09361	6	6.56168
2	1.82880	7	6.40080	2	2.18723	7	7.65529
3	2.74320	8	7.31520	3	3.28084	8	8.74891
4	3.65760	9	8.22960	4	4.37445	9	9.84252
5	4.57200	10	9.14400	5	5.46807	10	10.93614

MOVE DECIMAL POINT FOR HIGHER VALUES — e.g. 6,000 METERS = 6,561.68 YARDS

## POUNDS TO KILOGRAMS

## KILOGRAMS TO POUNDS

lb	kg	lb	kg	kg	lb	kg	lb
1	0.454	6	2.722	1	2.205	6	13.228
2	0.907	7	3.175	2	4.409	7	15.432
3	1.361	8	3.629	3	6.614	8	17.637
4	1.814	9	4.082	4	8.818	9	19.842
5	2.268	10	4.536	5	11.023	10	22.046

## GALLONS TO LITERS

## LITERS TO GALLONS

Gallons	Liters	Gallons	Liters	Liters	Gallons	Liters	Gallons
1	3.79	10	37.86	1	0.26	60	15.66
2	7.57	20	75.71	2	0.53	90	23.77
3	11.36	30	113.57	5	1.32	120	31.32
4	15.14	40	151.42	10	2.64	150	39.62
5	18.93	50	189.28	20	5.28	180	47.54

## PINTS TO LITERS

## LITERS TO PINTS

Pints	Liters	Pints	Liters	Liters	Pints	Liters	Pints
1	0.47	6	2.84	1	2.11	6	12.68
2	0.95	7	3.31	2	4.23	7	14.79
3	1.42	8	3.79	3	6.34	8	16.91
4	1.89	9	4.26	4	8.45	9	19.02
5	2.37	10	4.73	5	10.57	10	21.13

## TEMPERATURE

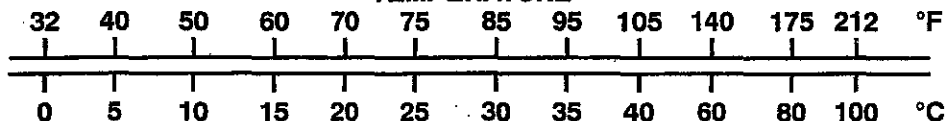

# INDEX

AC Terminal Connections (12 Stud) . . . . .	85	Governor . . . . .	91-92
Actuator Troubleshooting . . . . .	93	Heat Exchanger . . . . .	35
Air Intake/Silencer . . . . .	50	Idle Speed Adjustment . . . . .	53
Adjusting Idle Speed . . . . .	53	Injection Pump . . . . .	36-37
Adjusting Valve Clearance . . . . .	49	Injection Timing . . . . .	39
Alternator Testing . . . . .	62	Injectors Fuel . . . . .	40
Alternator/Mando . . . . .	64	Inspection . . . . .	16-34
Belt Adjustment . . . . .	53	Introduction . . . . .	4
BT Internal Wiring . . . . .	86	Mando Alternator Service . . . . .	64
Coolant Pump . . . . .	33	Metric Conversions (Chart) . . . . .	96-97
Compression-Engine . . . . .	50	Oil Pressure . . . . .	52
Compression-Low . . . . .	50	Parts Identification . . . . .	2-3
Conversion Formulas . . . . .	96	Raw Water Pumps . . . . .	46, 47, 48
Drive Belt Adjustment . . . . .	53	Sealants . . . . .	53
Engine Adjustment . . . . .	49-53	Sealants and Lubricants . . . . .	90
Engine Assembly . . . . .	27-35	Serial Number Location . . . . .	4
Engine Disassembly . . . . .	10-15	Service Standards and Limits . . . . .	54-55
Engine Inspection . . . . .	16	Solenoid-Fuel Shut-Off . . . . .	51
Engine Troubleshooting . . . . .	5	Solenoid-Fuel Run . . . . .	49
Exhaust Manifold . . . . .	35	Special Tools-Engine . . . . .	56
Fuel Injection Pump . . . . .	36-37	Special Tools-Generator . . . . .	94
Fuel Injection Timing . . . . .	39	<b>Specification Charts</b>	
Fuel Injectors . . . . .	40	44 Four Engine . . . . .	60
Fuel Run Solenoid . . . . .	51	35 Three Engine . . . . .	61
Fuel Shut-Off Solenoid . . . . .	51	10.0 Kw & 8.0 Kw BTDA . . . . .	73-75
<b>Generator-BT</b>		11.5 Kw & 12.6 Kw BTD . . . . .	74B
Introduction . . . . .	76	12.5 Kw BTDB . . . . .	74-75
12 Stud Wiring Schematic . . . . .	77	15 Kw BTDC . . . . .	74-75
6 Stud Wiring Schematic . . . . .	78	Standard Hardware . . . . .	95
AC Terminal Connections (12 Stud) . . . . .	85	Starter Motor . . . . .	42
Component Resistance Values . . . . .	79	Testing Engine Compression . . . . .	48
Frequency Adjustments . . . . .	51	Testing For Overhaul . . . . .	18
Internal Wiring/3 Phase . . . . .	86	Testing Oil Pressure . . . . .	50
Resistance Values . . . . .	86	Tools-Engine . . . . .	56
Schematic . . . . .	86	Torque Specifications . . . . .	57
AC Connections Volt Sensing . . . . .	86A	Transmission . . . . .	10
Terminal Block Wiring Connections (6 Stud) . . . . .	84	Troubleshooting-Engine . . . . .	5
Troubleshooting Chart . . . . .	79	Valve Clearance Adjustment . . . . .	49
Troubleshooting-Actuator . . . . .	93	Generator . . . . .	71
Troubleshooting-Residual Voltage . . . . .	80	Voltage Regulator . . . . .	88
3 Phase Schematic . . . . .	87	Water Pump-Coolant . . . . .	33
Bridge Rectifier . . . . .	80	Water Pump-Raw . . . . .	4-47
Compound Transformer . . . . .	82	<b>Wiring Schematics and Diagrams</b>	
Exciter Rotor Field . . . . .	83	Engine . . . . .	56-58
Main Stator Windings . . . . .	82	Generator . . . . .	71
Voltage Hertz Adjusting . . . . .	84	Generator with Electronic Governor . . . . .	89-90
Voltage Regulator . . . . .	88	Remote Instrument Panel . . . . .	72
Glow Plug Testing . . . . .	41		

